

r.LiNK Video-inserter

RL2-GVIF



**Compatible with
Chevrolet, Lexus and Toyota vehicles
with GVIF technology
and for Land Rover and Jaguar with
touch-screen navigation version 1 and 1.1**

**Video-inserter for rear-view camera input
and two additional video sources**

Product features

- Video-inserter for factory-infotainment systems
- 2 CVBS video-inputs for after-market devices (e.g. DVD-Player, DVB-T tuner)
- FBAS Rear-view camera video-input
- Automatic switching to rear-view camera input on engagement of the reverse gear
- Video-in-motion in drive mode (ONLY for connected video-sources)
- AV-inputs NTSC compatible

Contents

1. Prior to installation

- 1.1. Delivery contents
- 1.2. Checking the compatibility of vehicle and accessories
- 1.3. Connectors – video interface
- 1.4. Dip-switch settings
 - 1.4.1. Enabling the interface's video inputs (dip 2-3)
 - 1.4.2. Rear-view camera setting (dip 5)
 - 1.4.3. Monitor selection (dips 6-8)

2. Installation

- 2.1. Place of installation
- 2.2. Connection schema
- 2.3. Connecting video-interface and 6pin cable
- 2.4. Connection to the factory monitor
 - 2.4.1. Special case 1: For Jaguar and Land Rover vehicles with touch-screen version 1
 - 2.4.2. Special case 2: For Lexus/Toyota vehicles– picture is blinking after installation
- 2.5. Connecting video sources
 - 2.5.1. After-market rear-view camera
 - 2.5.2. Audio-insertion
- 2.6. Connecting video-interface and keypad
- 2.7. Picture settings

3. Interface operation

4. Specifications

5. Frequently asked questions

6. Technical support

Legal Information

By law, watching moving pictures while driving is prohibited, the driver must not be distracted. We do not accept any liability for material damage or personal injury resulting, directly or indirectly, from installation or operation of this product. This product should only be used while standing or to display fixed menus or rear-view-camera video when the vehicle is moving, for example the MP3 menu for DVD upgrades.

Changes/updates of the vehicle's software can cause malfunctions of the interface. We offer free software-updates for our interfaces for one year after purchase. To receive a free update, the interface must be sent in at own cost. Labor cost for and other expenses involved with the software-updates will not be refunded.

1. Prior to installation

Read the manual prior to installation.

Technical knowledge is necessary for installation. The place of installation must be free of moisture and away from heat sources.

1.1. Delivery contents

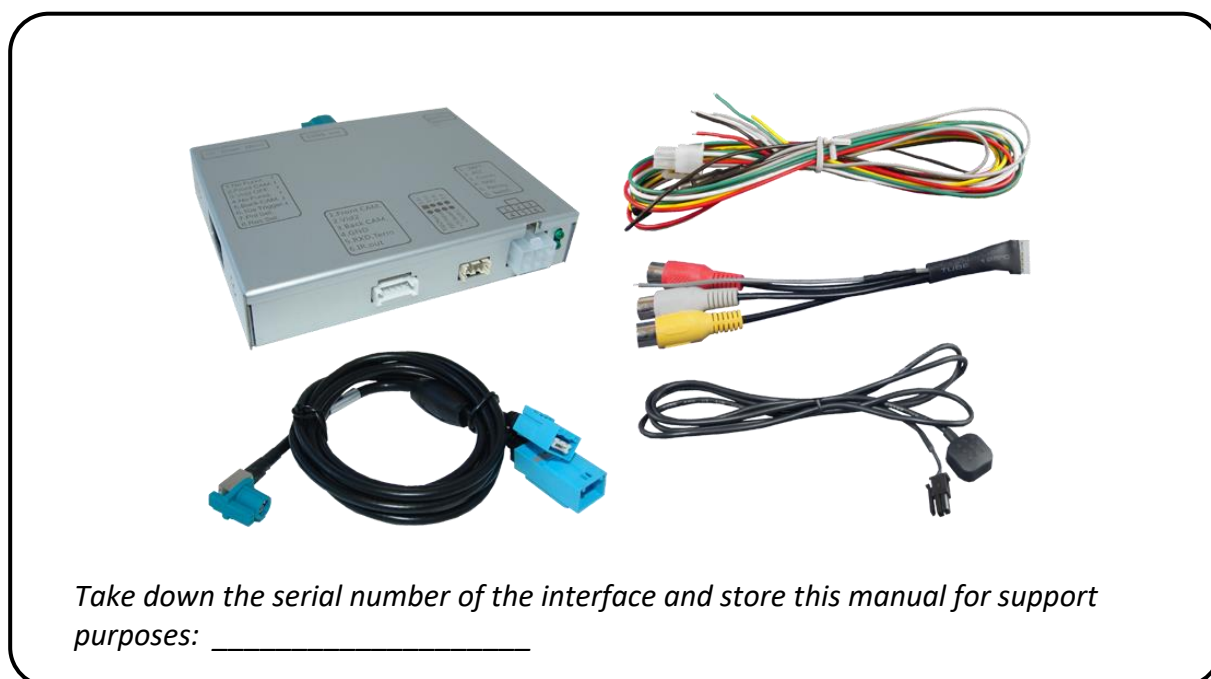

1.2. Checking the compatibility of vehicle and accessories

Requirements

Vehicle

Chevrolet Camaro model years 2013-2014

Lexus: LS/GS/RX/ES/IS, monitor and head-unit must be **separate units and connected with a GVIF cable!**

Toyota: Landcruiser, Prius and other vehicles from 2007 with GVIF technology, monitor and head-unit must be **separate units and connected with a GVIF cable!**

Jaguar: XF X250, XK X150 (Modelljahre 2007-2011)

Land Rover: Range Rover (Vogue) L322 (2005-2009), Range Rover Sport L320 (2005-2009), Discovery 3 L319 (2004-2009), Freelander 2 L359 (2007-2012)

Only Jaguar and Land Rover vehicles with factory navigation!

Head-unit/monitor

Chevrolet with 7" MyLink

Lexus and **Toyota** with GVIF-technology

Jaguar with touch-screen navigation version 1.1 (menu 2)

Land Rover with touch-screen navigation version 1 and 1.1 (menu 2)



Limitations

Video only

The interface inserts **ONLY** video signals into the infotainment. For sound use the possibly existing factory-audio-AUX-input or a FM-modulator.

Video insertion Jaguar/LR

The inserted video can only be seen in map mode of the factory navigation (the automatically switching to an after-market rear-view camera, too).

Jaguar/LR with Touch-screen version 1

Blue GVIF connectors of vehicle and interface have to be cut, changed against each other and soldered.

Factory rear-view camera

Automatical switching-back from inserted video to factory rear-view camera only while reverse gear is engaged. To delay the switch-back time, additional electronics is required.

1.3. Connectors – video interface

The video-interface converts the video signals of connected after-market sources in a factory monitor compatible picture signal which is inserted in the factory monitor, by using separate trigger options.

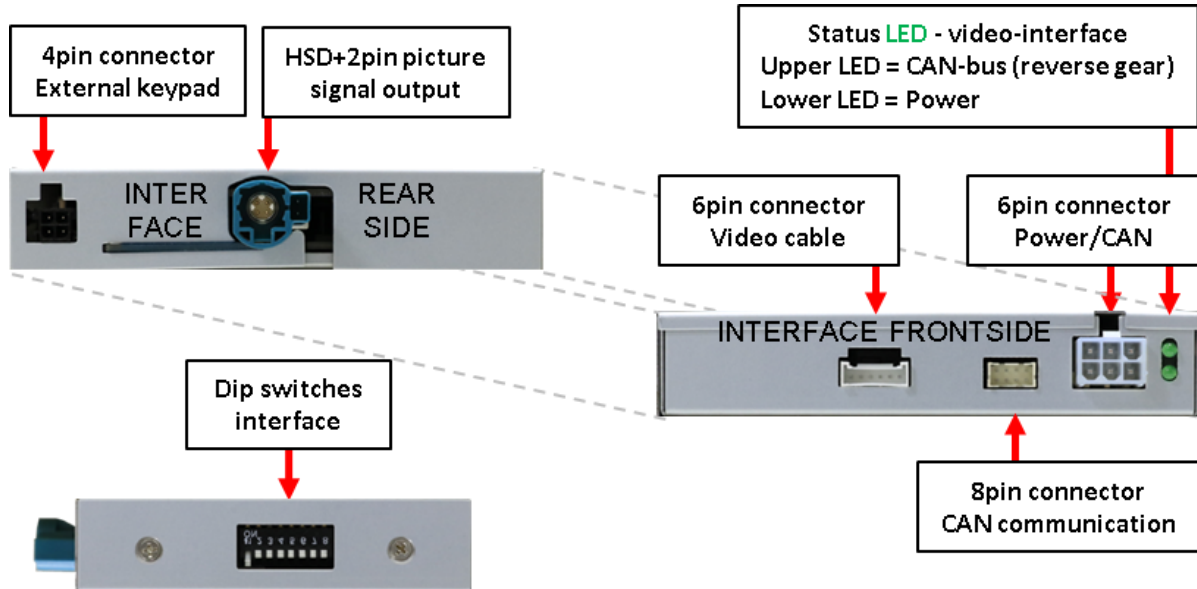

1.4. Dip-switch settings

Some settings must be selected by the dip-switches on the video-interface. Dip position down is ON and position up is OFF.



Dip	Function	ON (down)	OFF (up)
1	No function	-	set to OFF
2	CVBS AV1-input	enabled	disabled
3	CVBS AV2-input	enabled	disabled
4	No function	-	set to OFF
5	Rear-view cam type	after-market	factory or none
6	Monitor selection	Try all possible combinations of dip 6-8 to find the best picture (quality and size)	
7			
8			

After each Dip-switch-change a power-reset of the Can-box has to be performed!

See following chapters for detailed information.

1.4.1.1. Enabling the interface's video inputs (dip 2-3)

Only the enabled video inputs can be accessed when switching through the interface's video sources. It is recommended to enable only the required inputs for the disabled will be skipped when switching through the video-interfaces inputs.

1.4.1.2. Rear-view camera setting (dip 5)

If set to OFF, the interface switches to factory picture while the reverse gear is engaged to display factory rear-view camera.

If set to ON, the interface switches to its rear-view camera input „Camera-IN“ while the reverse gear is engaged.

1.4.1.3. Monitor selection (dips 6-8)

Dips 6-8 are for monitor-specific video settings which cannot be predicted as even within the same head-unit version, the monitor specifications may vary. It is necessary to try all possible combinations - while a working video source is connected to the chosen input of the interface - to see which combination gives the best picture quality and size (some may give no picture). It is possible to first hot plug through the dip combinations, but if you do not experience any change of picture after trying all options, retry and disconnected the 6pin power plug of the video-box between every change of the dip setting.

Note: Dip 1 und 4 are out of function and have to be set to **OFF**.

2. Installation

To install the interface, first switch off the ignition and disconnect the vehicle's battery. Please read the owner's manual of the car, regarding the battery's disconnection! If required, enable the car's Sleep-mode (hibernation mode)

In case the sleep-mode does not succeed, the disconnection of the battery can be done with a resistor lead.

If the necessary stabilized power supply for the interface is not taken directly from the battery, the chosen connection has to be checked for being constantly stabile.

The interface needs a permanent 12V source!

Note: Before a final installation, we recommend a test-run to ensure the compatibility of the vehicle and the interface. Due to changes in the production of the vehicle manufacturer there's always a possibility of incompatibility.

2.1. Place of installation

The interface is installed on the backside of the factory monitor.

2.2. Connection schema

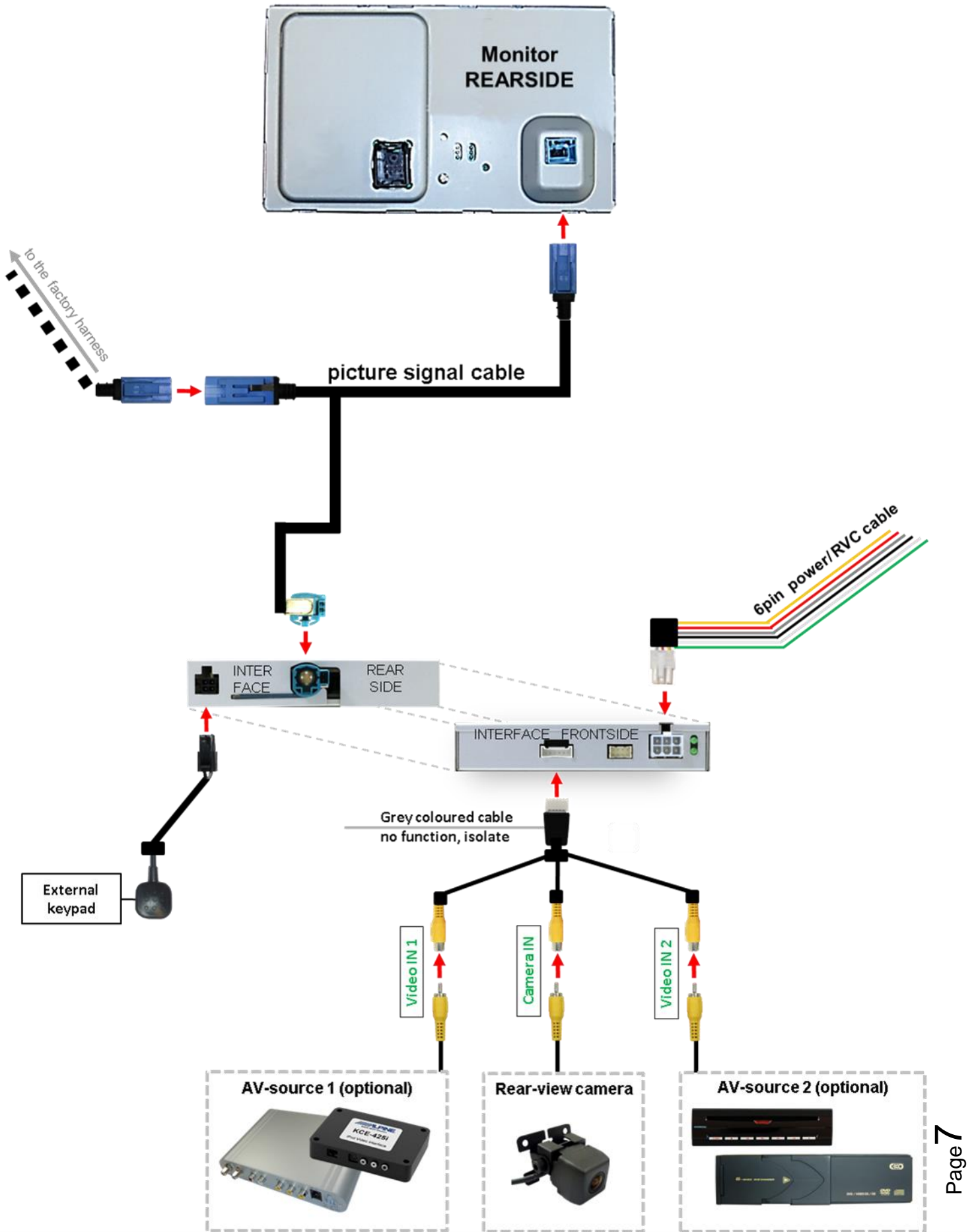

2.3. Connecting video-interface and 6pin cable

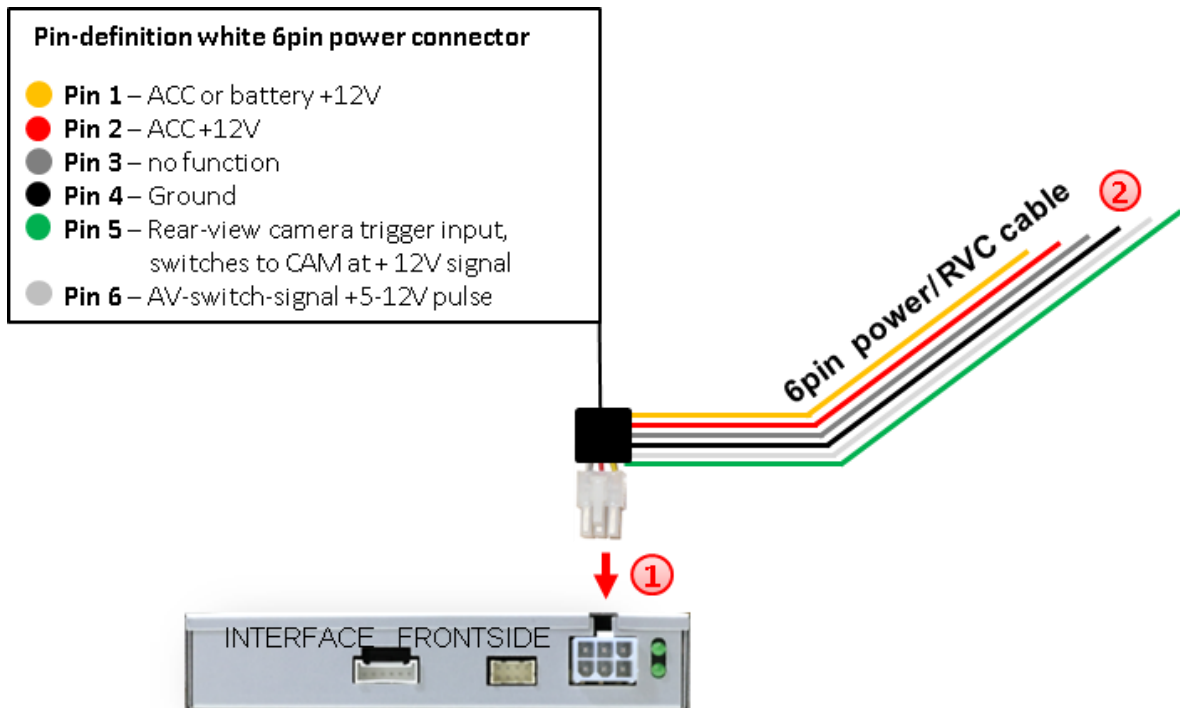

- ① Connect white female 6pin connector of the 6pin power / RVC cable to the male 6pin connector of the video-interface.
- ② Connect the wires of the 6pin power / RVC cable according to the upper diagram (Pin 1,2,4 und 5).

Note: Check the LEDs on video-interface after reconnecting the battery, one has to be on.

2.4. Connections to the factory monitor

Remove factory monitor.

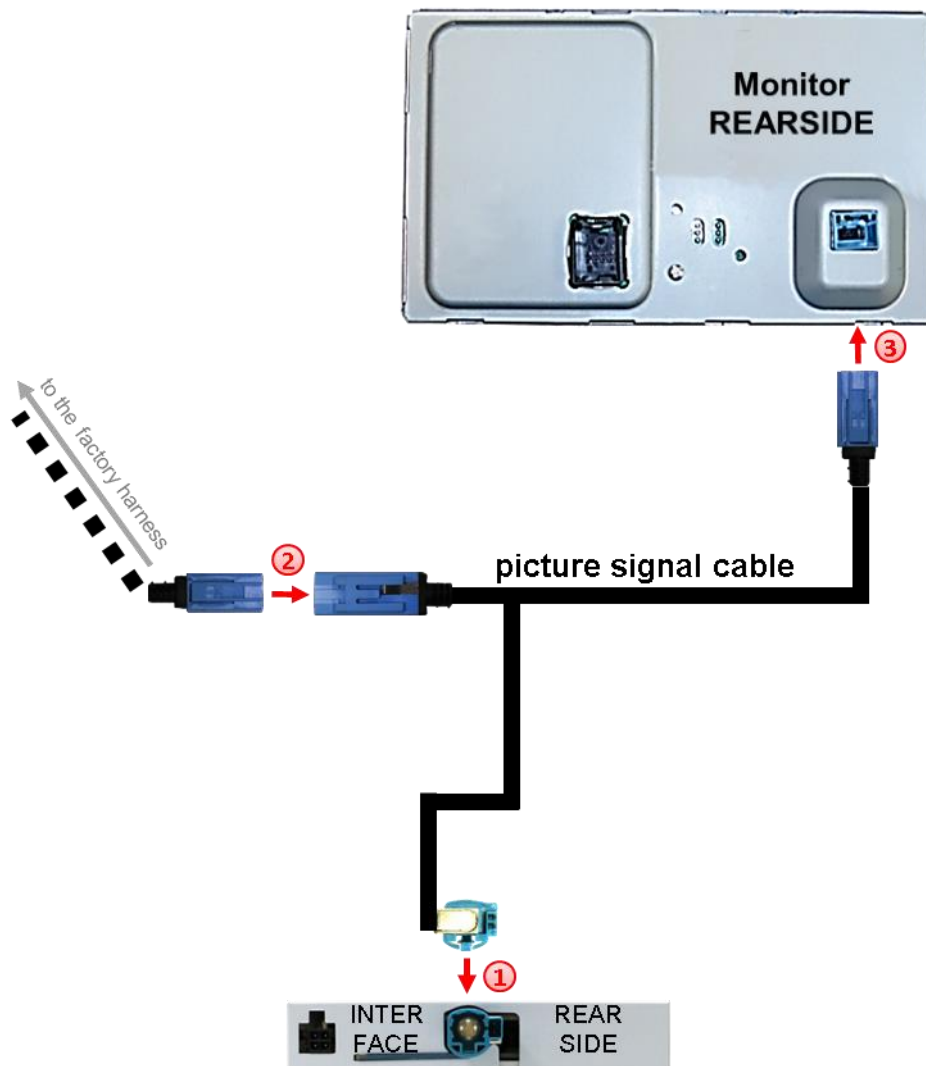

- 1 Connect female HSD+2pin connector of the picture signal cable to the male HSD+2pin connector on the rear-side of the interface.
- 2 Remove the female GVI connector from the rear-side of the factory monitor and connect it to the male GVI connector of the picture signal cable.
- 3 Connect female GVI connector of the picture signal cable to the male GVI connector of the factory monitor.

2.4.1. Special case 1: For Jaguar and Land Rover vehicles with touch-screen version-1

In vehicles with touch screen version-1, the female blue GVIF connectors of the vehicle harness and the female blue GVIF connector of the picture signal cable have to be cut, changed against each other and soldered.

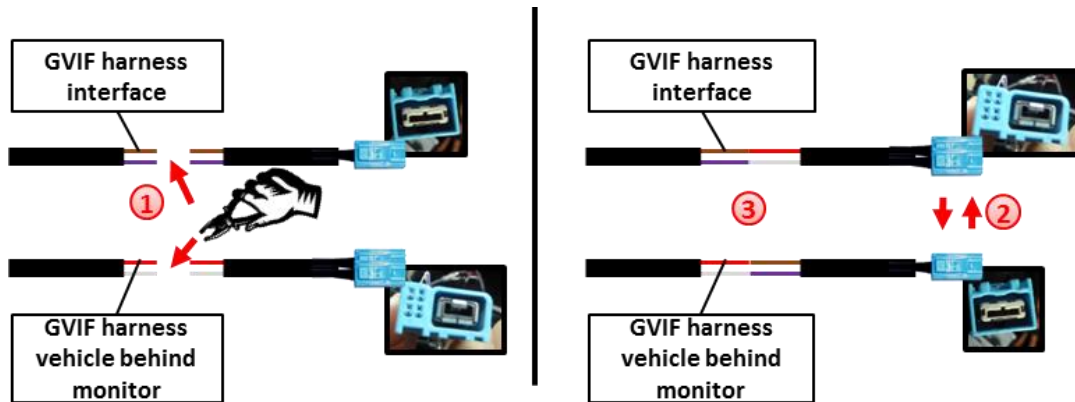

- ① Cut both female GVIF connectors of the vehicle harness and the picture signal cable with leaving enough cable on it.
- ② Change both female GVIF connectors against each other.
- ③ Solder the female GVIF connector of the vehicle harness to the picture signal cable and the GVIF connector of the picture signal cable to the vehicle harness. The red wire has to be soldered to the brown coloured wire and the white wire to the purple coloured wire.

2.4.2. Special case 2: For Lexus/Toyota vehicles – picture is blinking after the installation

In some vehicles (Lexus/Toyota) the picture is blinking after the installation. In this case the cable at the power connector of the factory monitor needs to be cut like in the picture below.

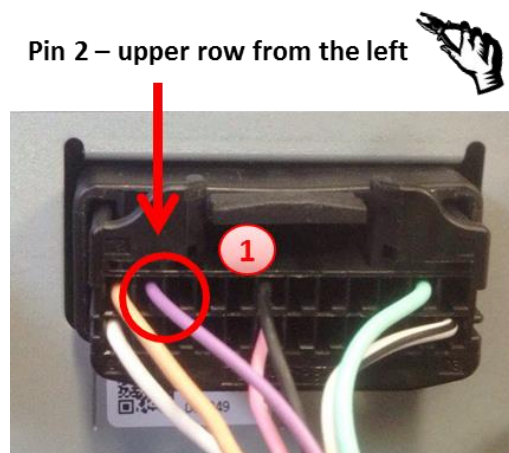

- ① Cut the cable at pin 2 of the upper row from the left side and isolate both ends.

Note: Cable colour of pin 2 may vary.

2.5. Connecting video sources

It is possible to connect one after-market rear-view camera and two more AV sources to the video-interface.

Note: Before the final installation, we recommend a test-run to ensure the compatibility of the vehicle and the interface. Due to changes in the production of the vehicle manufacturer there's always a possibility of incompatibility.

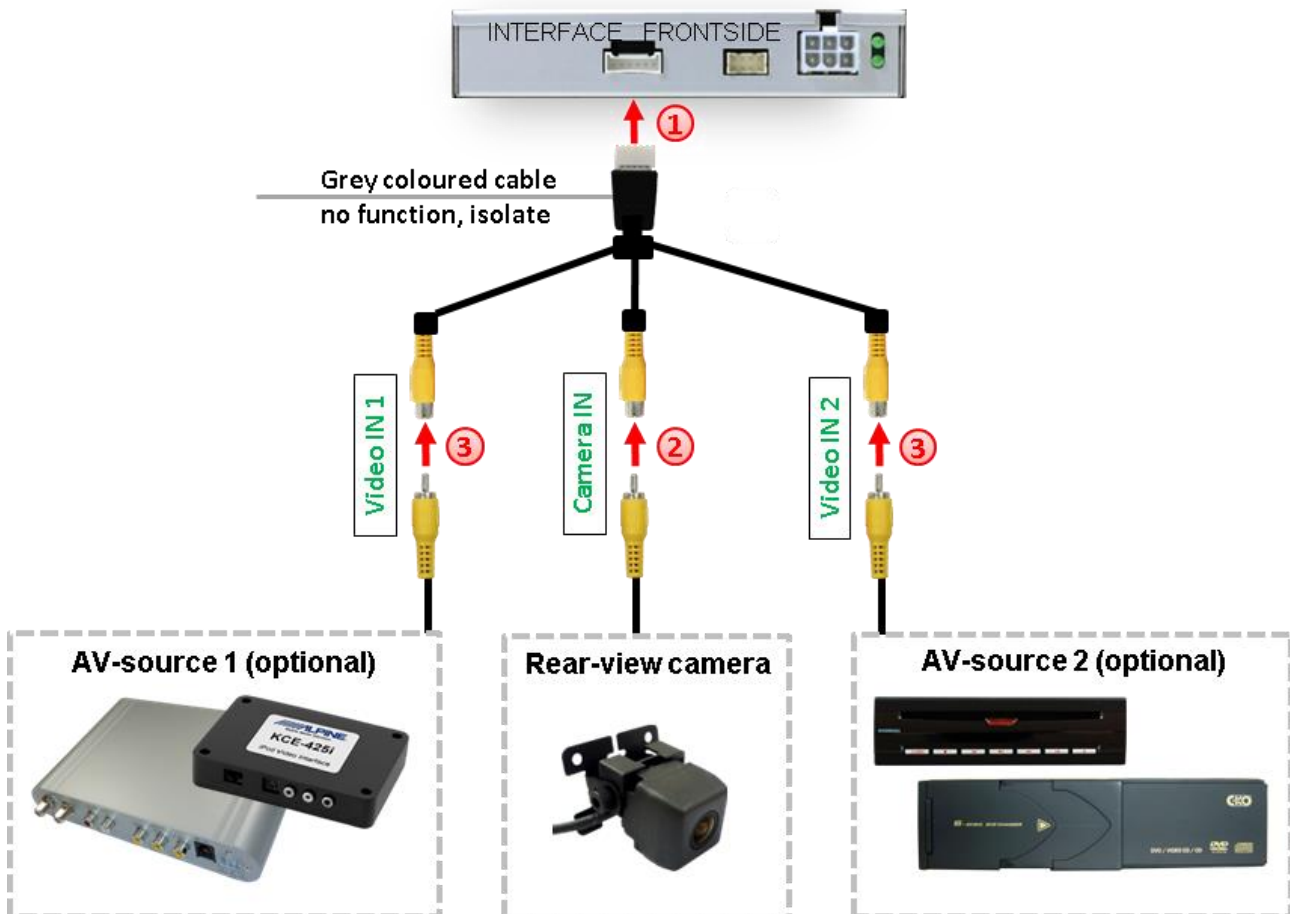

- ① Connect the female 6pin connector of the video cable to the male 6pin connector of the video-interface.
- ② Connect the video RCA connector of the rear-view camera to the female RCA connector **“Camera-IN”** of the video cable.
(see also **“After-market rear-view camera”**).
- ③ Connect the video RCA connectors of additional AV sources to the female RCA connectors **„Video IN 1”** und **“Video IN 2”**.

2.5.1. After-market rear-view camera

For activating the rear-view camera when reverse gear is engaged, an external switching signal from the reverse gear light is required. As the reverse gear light's power supply isn't voltage-stable all the time, an ordinary open relay (e.g AC-RW-1230 with wiring AC-RS5) or filter (e.g. AC-PNF-RVC) is required. The diagram below shows the connection type of the relay.

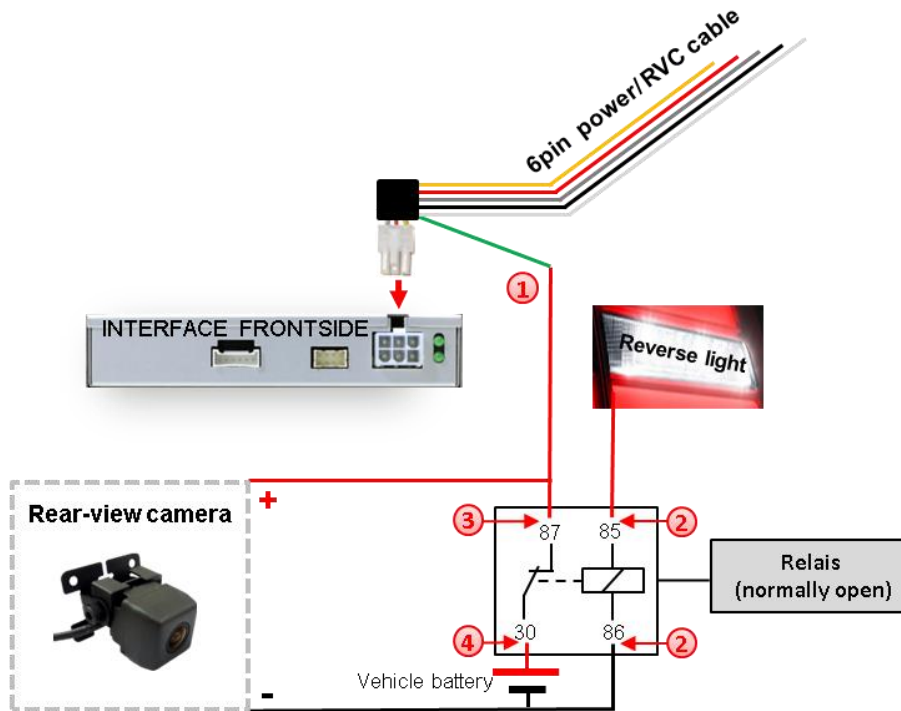

- ① Connect the green cable of the 6pin power / RVC cable to the output connector (87) of the relay.
- ② Connect the Reverse light's power-cable to coil (85) and the vehicle's ground to coil (86) of the relay.
- ③ Connect the output connector (87) of the relay to the rear-view camera's power-cable, like you did it with the green cable before.
- ④ Connect permanent power +12V to the relay's input connector (30).

Note: Don't forget to set the Dip 5 to ON.

In Jaguar and Land Rover vehicles the automatic switching to an after-market rear-view camera is only possible in navigation mode.

2.5.2. Audio Insertion

This interface can only insert video signals into the factory infotainment. If an AV-source is connected, audio insertion must be done by factory audio AUX input or FM-modulator. The inserted video-signal can be activated simultaneously to each audio-mode of the factory infotainment.

2.6. Connection Video Interface and external keypad

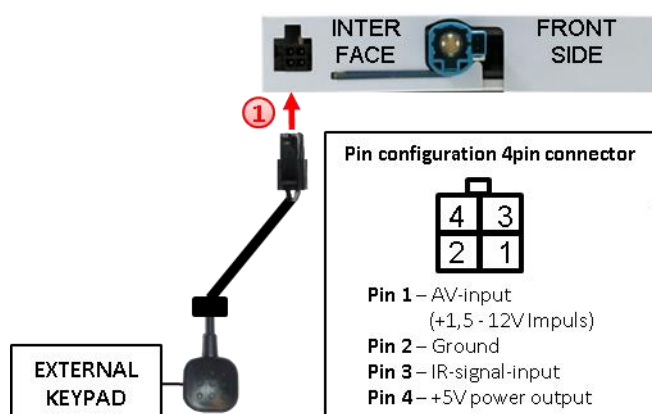

- 1 Connect the 4pin female connector of the external keypad to the male 4pin connector of the video interface.

Note: Regardless if it'll be used or not, the external keypad should always be connected! In case of non-using, it should be invisibly hidden together with the video interface.

2.7. Picture settings

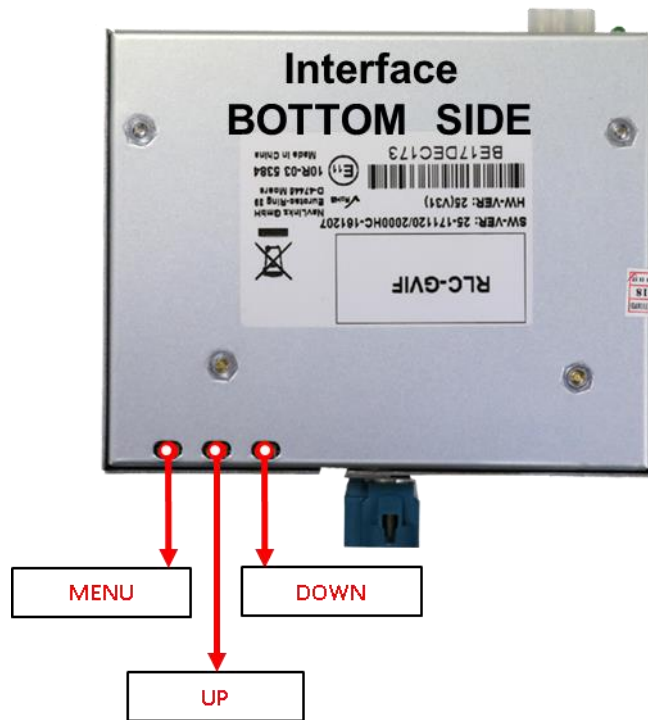

The picture settings are adjusted by the 3 buttons on the video-interface. Press the MENU button to open the OSD settings menu or to switch to the next menu item. Press UP and DOWN change the selected value. The buttons are embedded in the housing to avoid accidental changes during or after installation. Picture settings have to be done separately for AV1 and for AV2 while the corresponding input is selected and visible on the monitor. AV2 and CAM share the same settings which must be adjusted in AV2.

Note: The OSD menu is only shown when a working video source is connected to the selected video-input of the interface.

The following settings are available:

- Brightness
- Contrast
- Saturation
- Position H (horizontal)
- Position V (vertical)
- GVIF year
- UI-CNT no function

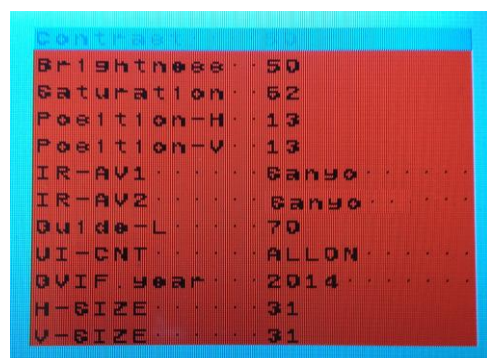

3. Interface operation

The interface's **keypad** can be used to execute interface functions.

Short press keypad to switch the video-source.

Each repetition will switch to the next enabled input. Inputs which are not enabled are skipped.

Note: The white wire of the 6pin cable can be used with a +5-12V pulse to switch the video-sources alternatively.

4. Specifications

BATT/ACC range	7V - 25V
Stand-by power drain	3mA
Power consumption	167mA
Video input	0.7V - 1V
Video input formats	NTSC
Temperature range	-40°C to +85°C
Dimensions video-box	113 x 22 x 107 mm (W x H x D)
Dimensions CAN-box	73 x 22 x 42 mm (W x H x D)

5. FAQ – Trouble shooting Interface functions

For any troubles which may occur, check the following table for a solution before requesting support from your vendor.

Symptom	Reason	Possible solution
No picture/black picture (factory picture).	Not all connectors have been reconnected to factory head-unit or monitor after installation.	Connect missing connectors.
	No power on CAN-bus box (all LED CAN-bus box are off).	Check power supply of CAN-bus box. Check CAN-bus connection of CAN-bus box.
	CAN-bus box connected to CAN-bus in wrong place.	Refer to the manual where to connected to the CAN-bus. If not mentioned, try another place to connect to the CAN-bus.
	No power on video-interface (all LED video-interface are off).	Check whether CAN-bus box delivers +12V ACC on red wire output of 8pin to 6pin cable. If not cut wire and supply ACC +12V directly to video-interface.
No picture/black picture/white picture (inserted picture) but factory picture is OK.	No picture from video source.	Check on other monitor whether video source is OK.
	No video-source connected to the selected interface input.	Check settings dips 1 to 3 of video interface which inputs are activated and switch to corresponding input(s).
	LVDS cables plugged in wrong place.	Double-check whether order of LVDS cables is exactly connected according to manual. Plugging into head-unit does not work when the manual says to plug into monitor and vice versa.
Inserted picture totally wrong size or position.	Wrong monitor settings of video-interface.	Try different combinations of dips 7 and 8 of video-interface. Unplug 6pin power after each change.
Inserted picture double or 4 times on monitor.		
Inserted picture distorted, flickering or running vertically.	Video sources output set to AUTO or MULTI which causes a conflict with the interfaces auto detection.	Set video source output fixed to PAL or NTSC. It is best to set all video sources to the same standard.
	If error occurs only after source switching: Connected sources are not set to the same TV standard.	Set all video sources to the same standard.
	Some interfaces can only handle NTSC input.	Check manual whether there is a limitation to NTSC mentioned. If yes, set source fixed to NTSC output.
Inserted picture b/w.	Picture settings have not been adjusted.	Use the 3 buttons and the interface's OSD to adjust the picture settings for the corresponding video input.
Inserted picture qual. bad.		
Inserted picture size slightly wrong.		
Inserted picture position wrong.		
Camera input picture flickers.	Camera is being tested under fluorescent light which shines directly into the camera.	Test camera under natural light outside the garage.
Camera input picture is bluish.	Protection sticker not removed from camera lens.	Remove protection sticker from lens.

Symptom	Reason	Possible solution
Camera input picture black.	Camera power taken directly from reverse gear lamp.	Use relay or electronics to "clean" reverse gear lamp power. Alternatively, if CAN-bus box is compatible with the vehicle, camera power can be taken from green wire of 6pin to 8pin cable.
Camera input picture has distortion.		
Camera input picture settings cannot be adjusted.	Camera input picture settings can only be adjusted in AV2 mode.	Set dip 3 of video-interface to ON (if not input AV2 is not already activated) and connect the camera to AV2. Switch to AV2 and adjust settings. Reconnect camera to camera input and deactivate AV2 if not used for other source.
Graphics of a car in camera input picture.	Function PDC is ON in the interface OSD.	In compatible vehicles, the graphics will display the factory PDC distance. If not working or not wanted, set interface OSD menu item UI-CNTRL to ALLOFF.
Chinese signs in camera input picture	Function RET or ALL is ON (function for Asian market) in the interface OSD.	Set interface OSD menu item UI-CNTRL to ALLOFF or PDCON.
Not possible to switch video sources by OEM button.	CAN-bus interface does not support this function for vehicle.	Use external keypad or cut white wire of 6pin to 8pin cable and apply +12V impulses for AV-switching.
Not possible to switch video sources by external keypad.	Pressed too short.	For video source switching a longer press of about 2.5 seconds is required.
	SW-version of interface does not support external keypad.	Use OEM-button or cut white wire of 6pin to 8pin cable and apply +12V impulses for AV-switching.
Interface does not switch to camera input when reverse gear is engaged.	CAN-bus interface does not support this function for the vehicles.	Cut the green wire of the 6pin to 8pin cable and apply +12V constant from reverse gear-lamp signal. Use relay to "clean" R-gear lamp power.
Interface switches video-sources by itself.	CAN-bus interface compatibility to vehicle is limited.	Cut the grey wire of 6pin to 8pin and isolate both ends. If problem still occurs, additionally cut the white wire of 6pin to 8pin cable and isolate both ends.

6. Technical Support

Please note that direct technical support is only available for products purchased directly from NavLinkz GmbH. For products bought from other sources, contact your vendor for technical support.

NavLinkz GmbH
distribution/tech dealer-support
 Heidberghof 2
 D-47495 Rheinberg

Tel +49 2843 17595 00

Email mail@navlinkz.de

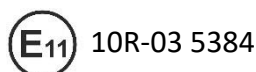

Made in China

