

Video-inserter RL4-UCON5-F

Beispiele Uconnect VP2 / RA2



**Compatible with
Alfa Romeo, Citroen, Dodge, Fiat, Jeep, Opel and Peugeot
vehicles with Uconnect 5 VP2 / RA2 System
and DIN housing behind the head unit's front panel**

**Video-inserter for front- and rear-view camera
and two additional video sources**

Product features

- Video-inserter for factory-infotainment systems
- 1 CVBS Input for rear-view camera
- 1 CVBS Input for front camera
- 2 CVBS video-inputs for after-market devices (e.g. USB-Player, DVB-T2 tuner)
- Automatic switching to rear-view camera input on engagement of the reverse gear
- Automatic front camera switching after reverse gear for 10 seconds
- Video-in-motion (ONLY for connected video-sources)
- Video-inputs NTSC compatible

Contents

1. Prior to installation

- 1.1. Delivery contents
- 1.2. Checking the compatibility of vehicle and accessories
- 1.3. Connectors-video interface
- 1.4. Settings of the 8 Dip switches (black)
 - 1.4.1. Activating the front camera input
 - 1.4.2. Enabling the interface's video inputs (dip 2-3)
 - 1.4.3. Rear-view camera setting (dip 5)
- 1.5. Settings of the 4 Dip switches (CAN function – red)

2. Installation

- 2.1. Place of installation – video interface
 - 2.1.1. Place of installation – Exchange housing base plate with daughter PCB
- 2.2. Connection schema
- 2.3. Connection to the head-unit – LVDS
 - 2.3.1. Exception for Chrysler vehicles
 - 2.3.2. Warning notes, concerning the installation of ribbon cables
- 2.4. Head unit – frame customizing
- 2.5. Connection – 20pin picture signal cable
- 2.6. Connection – PNP Quadlock harness
- 2.7. Analog power supply for the video interface
- 2.8. Power supply output
- 2.9. Connection - video sources
 - 2.9.1. Audio-insertion
 - 2.9.2. After-Market Frontkamera
 - 2.9.3. After-market rear-view camera
 - 2.9.3.1. Case 1: Video-interface receives the reverse gear signal
 - 2.9.3.2. Case 2: Video interface does not receive the reverse gear signal
- 2.10. Connection – external keypad
- 2.11. Picture settings

3. Interface operation

4. Specifications

5. FAQ – Trouble shooting

6. Technical support

Legal Information

By law, watching moving pictures while driving is prohibited, the driver must not be distracted. We do not accept any liability for material damage or personal injury resulting, directly or indirectly, from installation or operation of this product. Apart from using this product in an unmoved vehicle, it should only be used to display fixed menus or rear-view-camera video when the vehicle is moving (for example the MP3 menu for DVD upgrades).

Changes/updates of the vehicle's software can cause malfunctions of the interface. Up to one year after purchase we offer free software-updates for our interfaces. To receive a free update, the interface has to be sent in at own cost. Wages for de-and reinstallation and other expenditures involved with the software-updates will not be refunded.

1. Prior to installation

Read the manual prior to installation. Technical knowledge is necessary for installation. The place of installation must be free of moisture and away from heat sources.

1.1. Delivery contents

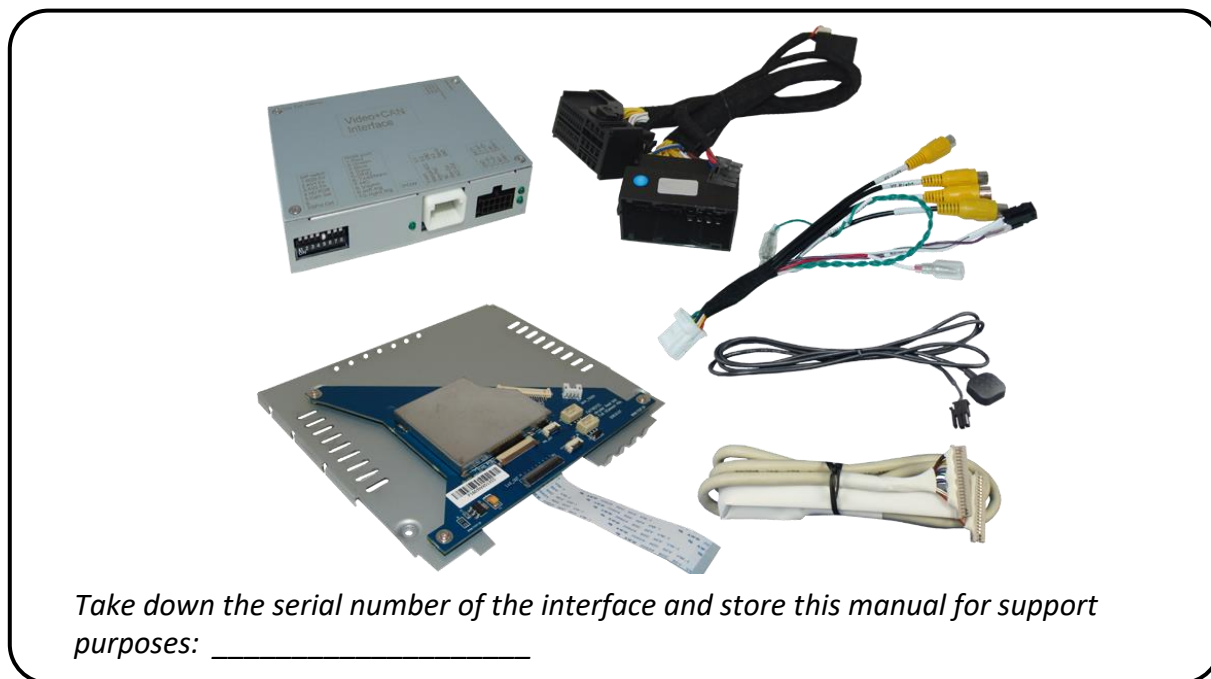

1.2. Checking the compatibility of vehicle and accessories

Compatibility		
Brand	Compatible vehicles	Infotainment systems
Alfa Romeo	Giulietta (940) Facelift 2013 08/2013-03/2016, MiTo since about 2014	Uconnect 5 VP2/RA2 with DIN-shell behind the head unit's front-panel*
Citroen	Jumper since 05/2014, Relay since 05/2014	
Dodge	RAM 1500/2500/3500 model year 2013-2018 and other models with	
Fiat	500, 500L, Doblo, Ducato3 (250/251/X290) 06/2016 until model year 2020, Tipo and other models with	
Jeep	Renegade since model year 2014	
Opel	Movano C since 05/2021	
Peugeot	Boxer since model year 2012	
Limitations		
<i>Video only</i>	The interface inserts ONLY video signals into the infotainment. For audio inserting, use the possibly existing factory audio-AUX-input or a FM-modulator. If 2 AV-sources shall be connected to the infotainment, for audio switching an additional electronic part is required.	
<i>Factory rear-view camera</i>	Automatically switching-back from inserted video to factory rear-view camera is only possible while the reverse gear is engaged. To delay the switch-back, an additional electronic part is required.	
<i>After market front camera</i>	The front camera will automatically be switched for 10 seconds after disengaging the reverse gear. A manually front camera switching is possible by external keypad.	
<i>Video input signal</i>	NTSC video sources compatible only.	

***Note:** Units with a CD drive always have a DIN-shell behind the head unit's front-panel. Units without a CD drive are available with and without a DIN-shell. For units without DIN-shell, the RL4-UCON5-CP is the suitable interface.

1.3. Connectors - Video-Interface

The video-interface converts the connected after-market sources video signals into an RGB digital signal which is inserted in the factory monitor using separate trigger options and it reads vehicle's digital signals out of the vehicle's CAN-bus and converts them for the video interface.

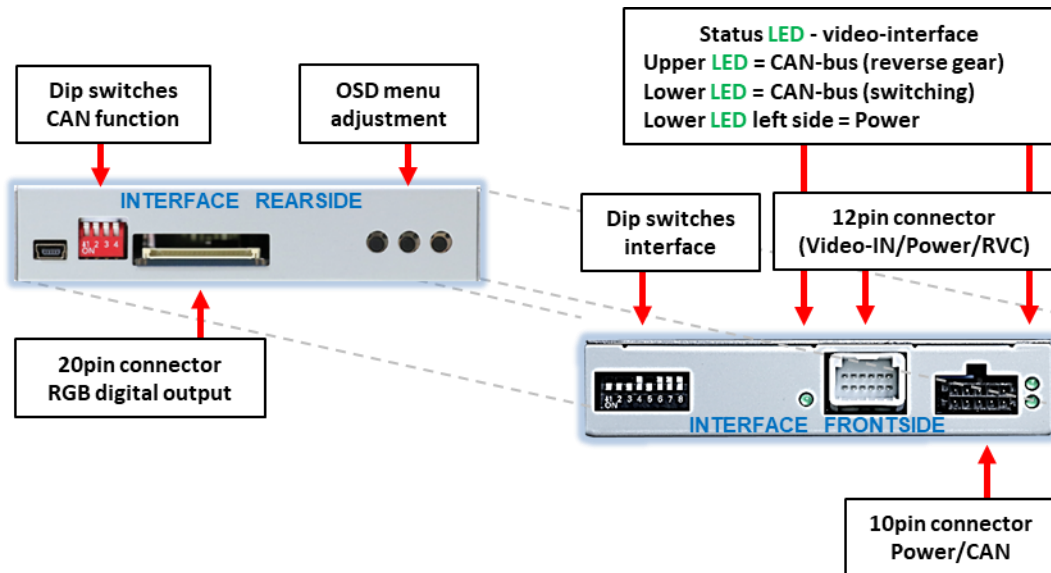

1.4. Settings of the 8 Dip switches (black)

Some settings have to be selected by the 8 dip-switches at the video-interface. Dip position down is ON and position up is OFF.



Dip	Function	ON (down)	OFF (up)
1	Front camera	enabled*	disabled
	Power supply output (red wire)	+12V (max. 3A) when reverse gear is engaged incl. 10 seconds delay and +12V by manual switching to front camera by keypad	+12V (max. 3A) ACC
2	CVBS AV1-input	enabled	disabled
3	CVBS AV2-input	enabled	disabled
4	No function		Set to OFF
5	Rear-view cam type	after-market	factory or none
6	No function		Set to OFF
7	No function		Set to OFF
8	No function		Set to OFF

*The front camera will automatically be switched for 10 seconds after disengaging the reverse gear.

See the following chapters for detailed information.

1.4.1. Activating the front camera input (dip 1)

If set to ON, the interface switches for 10 seconds from the rear-view camera to the front camera input after having disengaged the reverse gear. In addition, a manual switch-over to the front camera input is possible via keypad (short press) from any image mode.

Description of the power supply output: see chapter "Power supply output".

1.4.2. Enabling the interface's video inputs (dip 2-3)

Only the enabled video inputs can be accessed when switching through the interface's video sources. It is recommended to enable only the required inputs, disabled inputs will be skipped when switching through the video-interfaces inputs.

1.4.3. Rear-view camera setting (dip 5)

If set to OFF, the interface switches to factory picture while the reverse gear is engaged to display factory rear-view camera.

If set to ON, the interface switches to its rear-view camera input „Camera-IN“ while the reverse gear is engaged.

Note: Dips 4, 6, 7 and 8 are out of function and have to be set to **OFF**.

After each Dip-switch-change a power-reset of the Video Interface has to be performed!

1.5. 4 dip - red

By using the Dip-switches, the factory Head-unit or vehicle can be chosen which the interface will be connected to.

Dip position down is ON and position up is OFF.

Set all dip switches to off



Vehicle/Navigation	Dip 1	Dip 2	Dip 3	Dip 4
All vehicles	OFF	OFF	OFF	OFF

2. Installation

To install the interface, first switch off the ignition and disconnect the vehicle's battery. Please read the owner's manual of the car, regarding the battery's disconnection! If required, enable the car's Sleep-mode (hibernation mode)
In case the sleep-mode does not succeed, the disconnection of the battery can be done with a resistor lead.

As with any installation of retrofit equipment, a stand-by test is necessary after the installation of the video interface, to ensure that the unit also switches off after reaching the vehicle's sleep mode.

Before the final installation, we recommend a test-run of the interface. Due to changes in the production of the vehicle manufacturer, there's always the possibility of incompatibility.

2.1. Place of installation – video-interface

The video-interface is installed on the backside of the head-unit.

2.1.1. Place of installation - Exchange housing base plate with daughter PCB

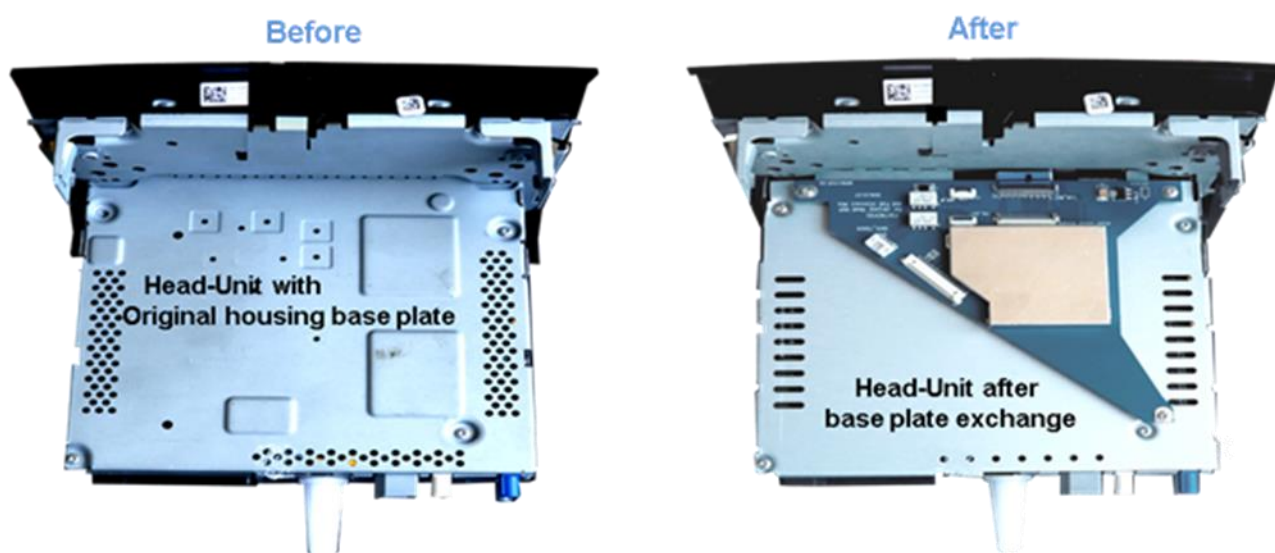

2.2. Connection schema

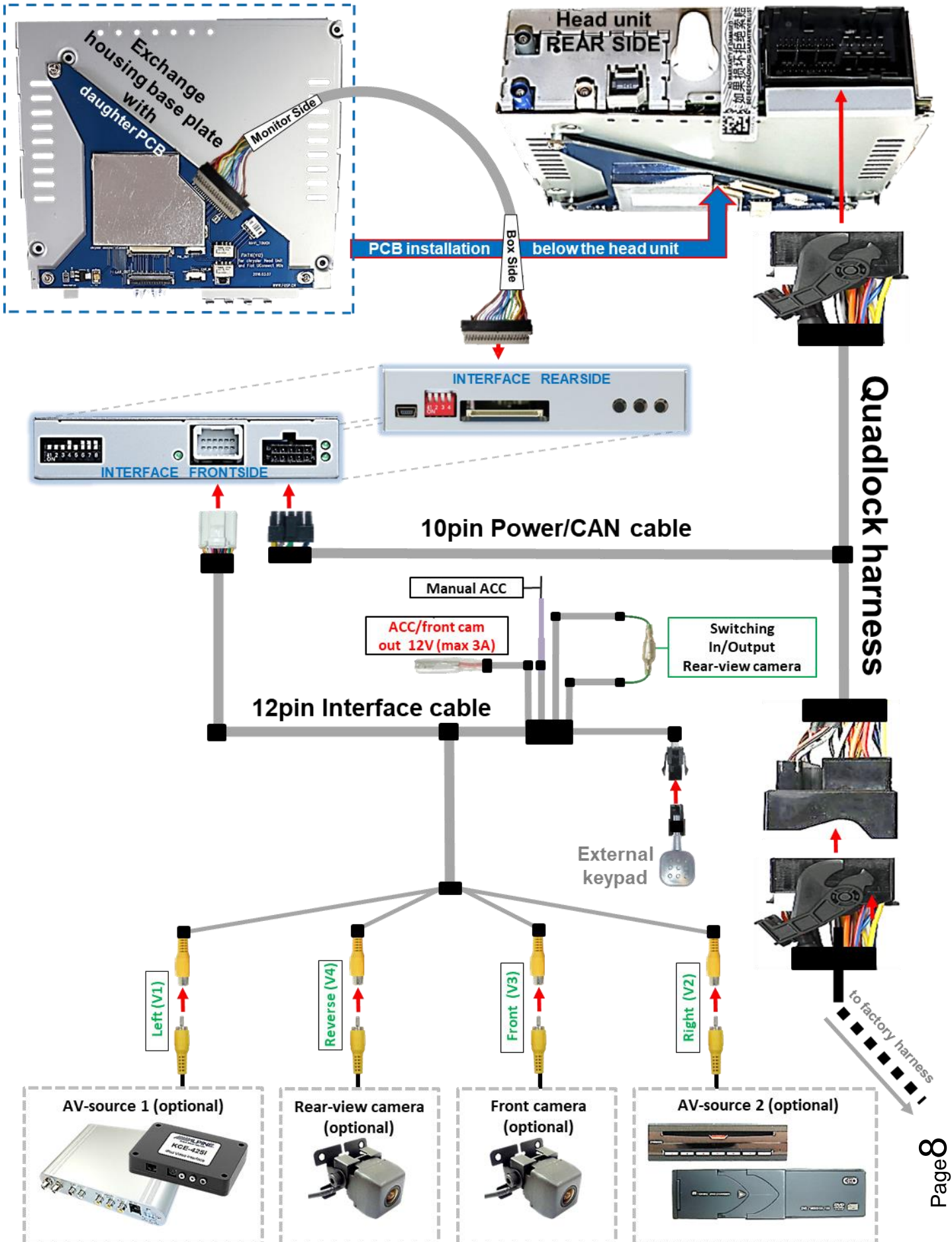

2.3. Connections to the head-unit - LVDS

Remove the head-unit and further remove the original housing base plate, which is fixed to the head-unit housing by 4 Torx screws (T9).

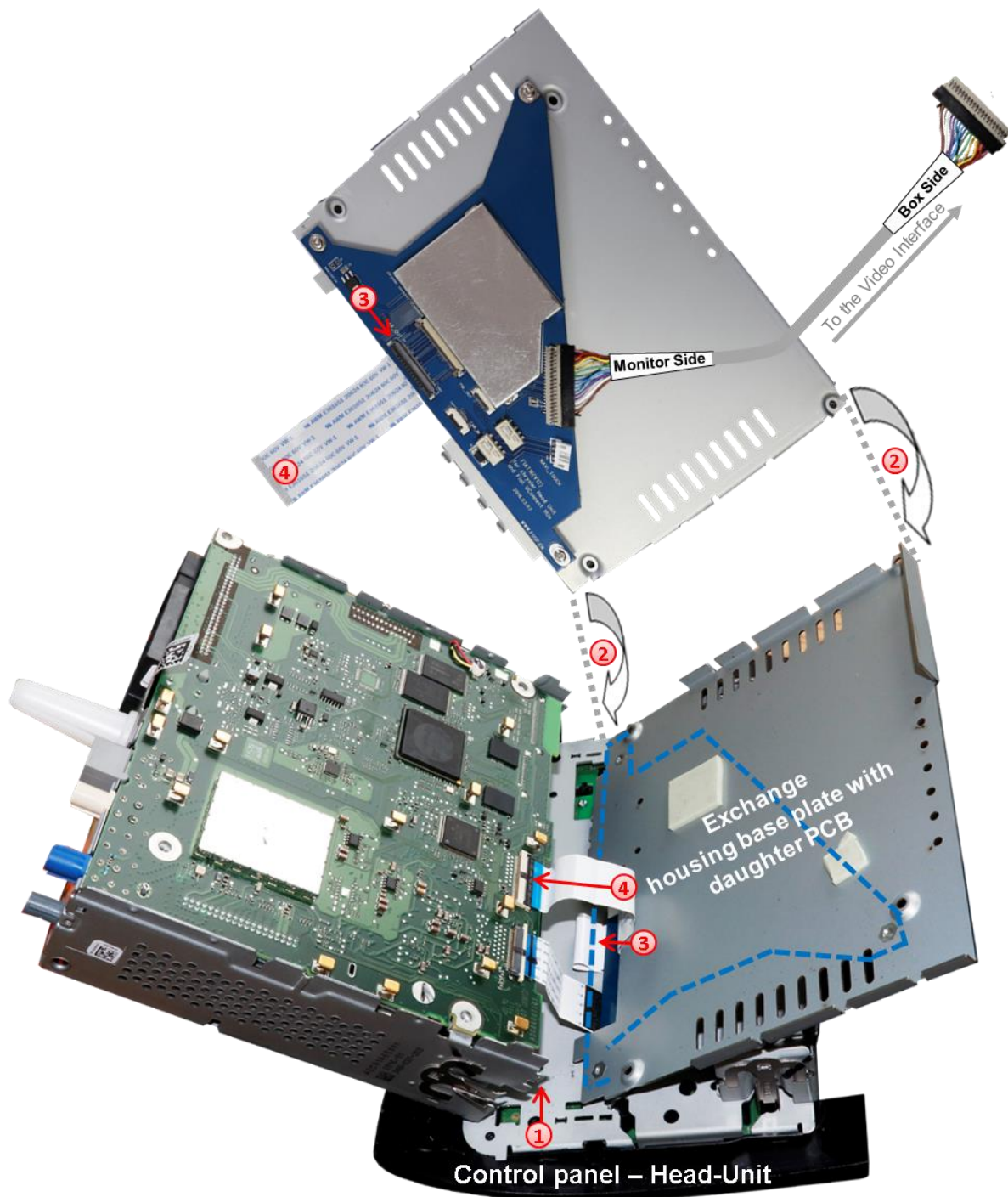

- 1** Clip out the head-unit housing at the head-unit control panel and fold it to the side, like shown in the picture above.
Note: The connected ribbon cables have to be handled with care to avoid each damage of the sensitive electrical inductors.
- 2** Position the Exchange housing base plate with the daughter PCB in place of the original base plate

- 3 Clip out the original 40pin ribbon cable which is connected at the head-unit's ribbon cable base and connect it to the lower free ribbon cable base "Lcd OUT" of the daughter PCB. (heed the following warning notes!)

Note: Due to the very short length of the ribbon cable, there's only limited space for mounting available.

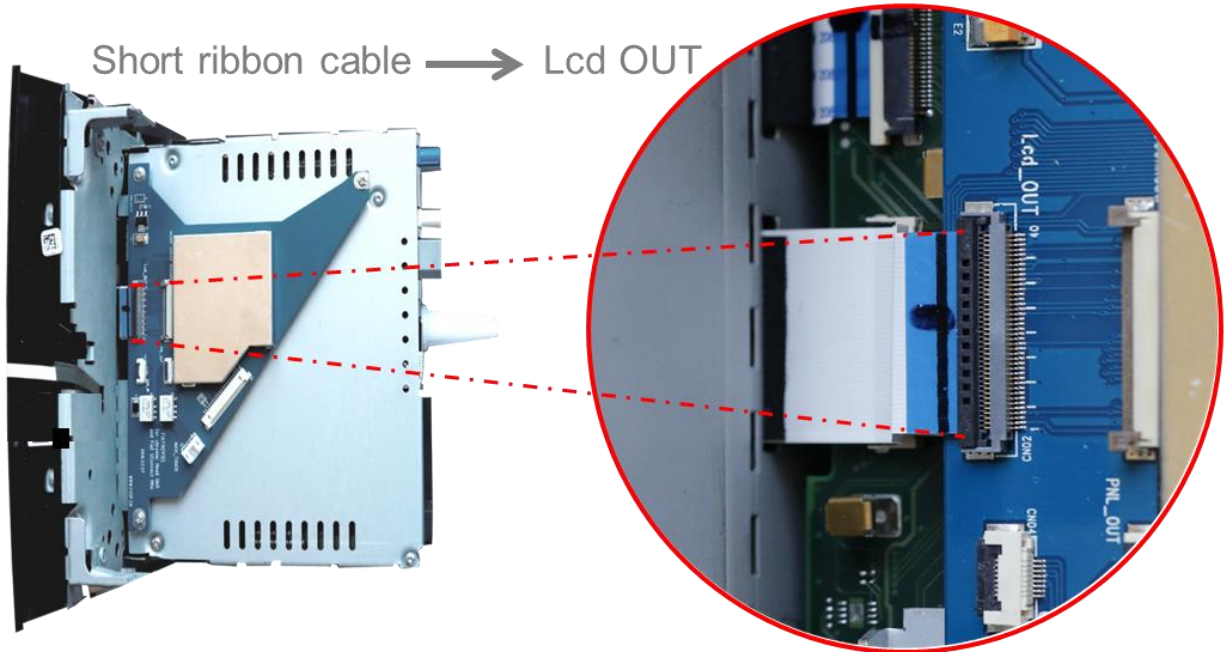

- 4 Connect the daughter PCB's pre-assembled 40pin ribbon cable to the previously become free ribbon cable base of the head-unit mainboard. (heed the following warning notes!).

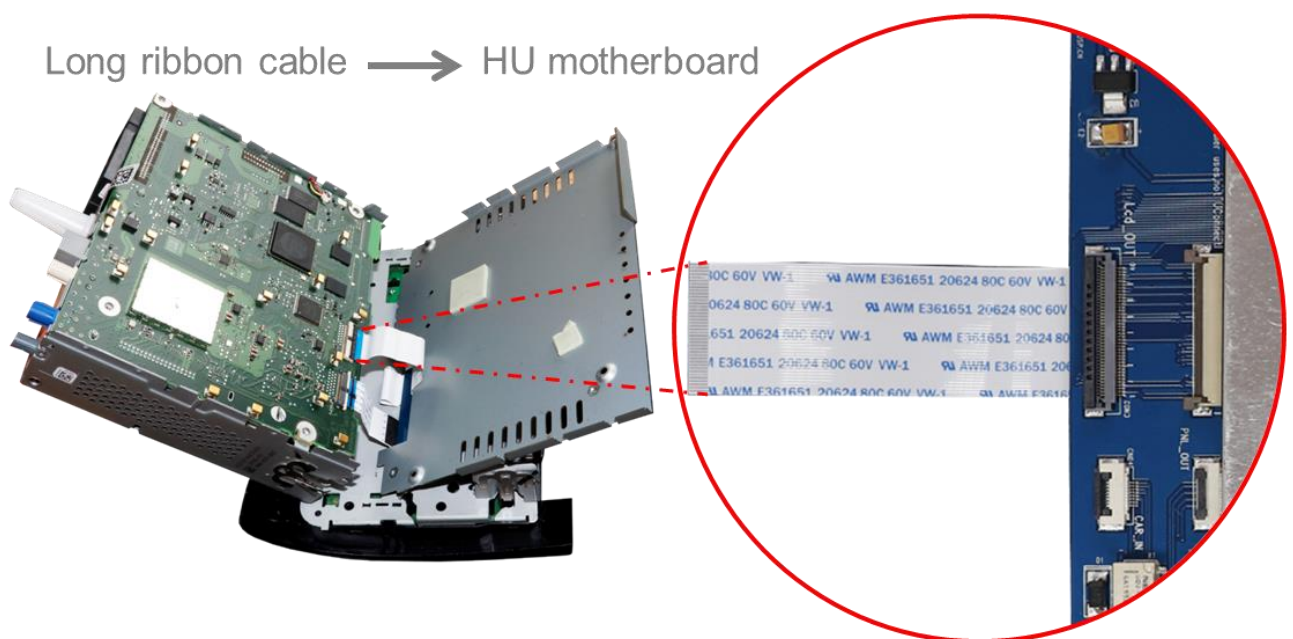

After a check of the perfect ribbon cable connection, in reverse order fold back and clip in the head-unit housing to the head-unit control panel and fix the exchange housing base plate to the head-unit's housing.

2.3.1. Exception for Chrysler vehicles

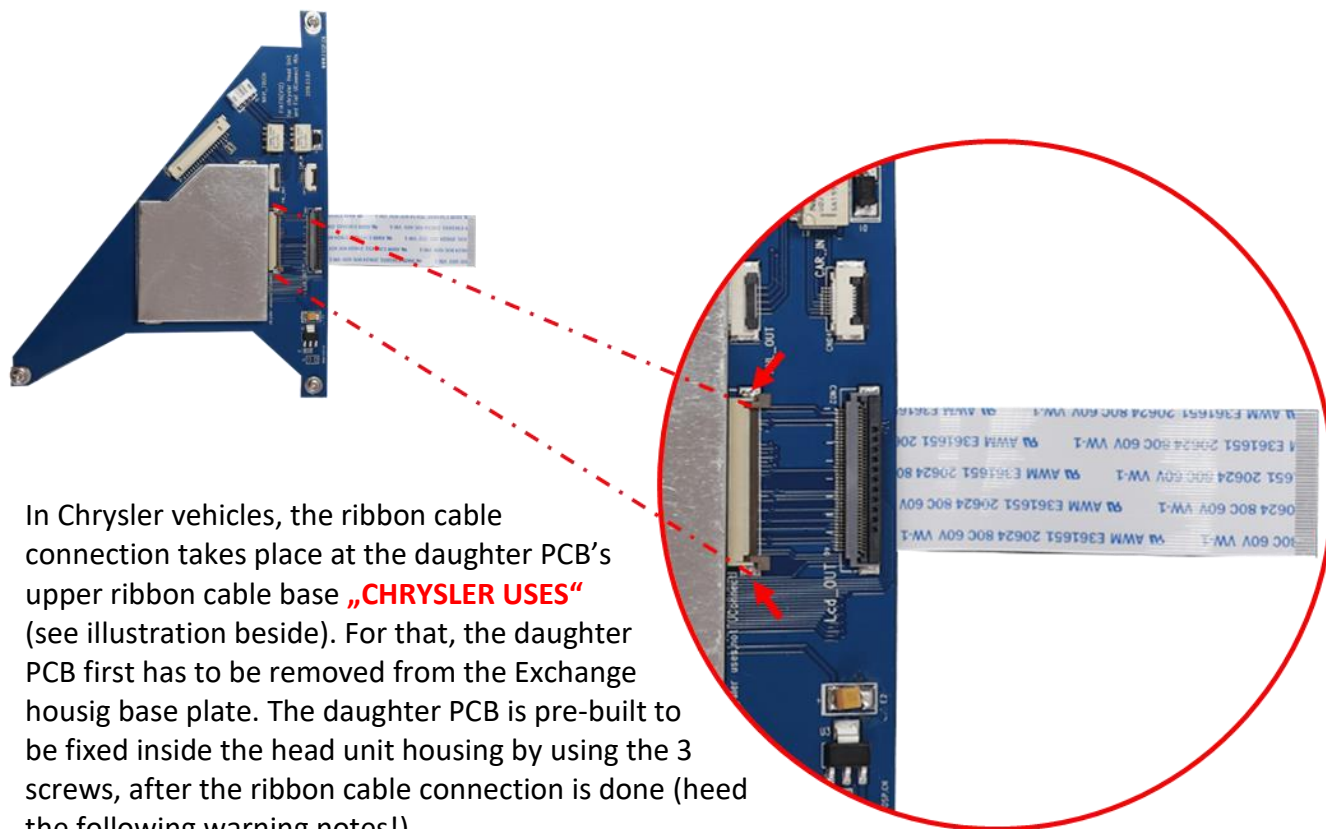

In Chrysler vehicles, the ribbon cable connection takes place at the daughter PCB's upper ribbon cable base „**CHRYSLER USES**“ (see illustration beside). For that, the daughter PCB first has to be removed from the Exchange housing base plate. The daughter PCB is pre-built to be fixed inside the head unit housing by using the 3 screws, after the ribbon cable connection is done (heed the following warning notes!).

2.3.2. Warning notes, concerning the installation of ribbon cables:

- 1) The contacting ends of ribbon cables always have to be installed in a straight and precise 180° position to the connector. Each deviation from a perfect contact position will cause faulty contact and even danger of short circuit
- 2) The ribbon cable's contacting side always has to correspond to the contacting side of the connector, concerning the mounting position.
- 3) Avoid cable contusion or cable injury caused by sharp-edged metal.

2.4. Head unit – frame customizing

To reinstall the head-unit's DIN housing with the daughter PCB below, in most cases a modification of the vehicle's head unit frame is required. For that, the sheet metal plate between the red marked lines has to be cut away, like shown in the following picture.

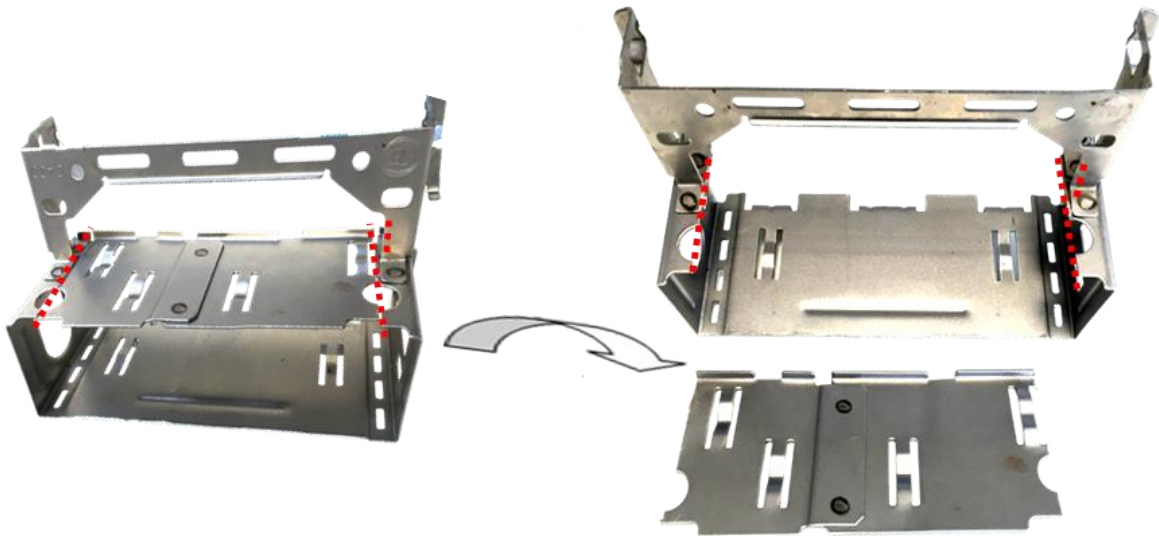

2.5. Connection – 20pin picture signal cable

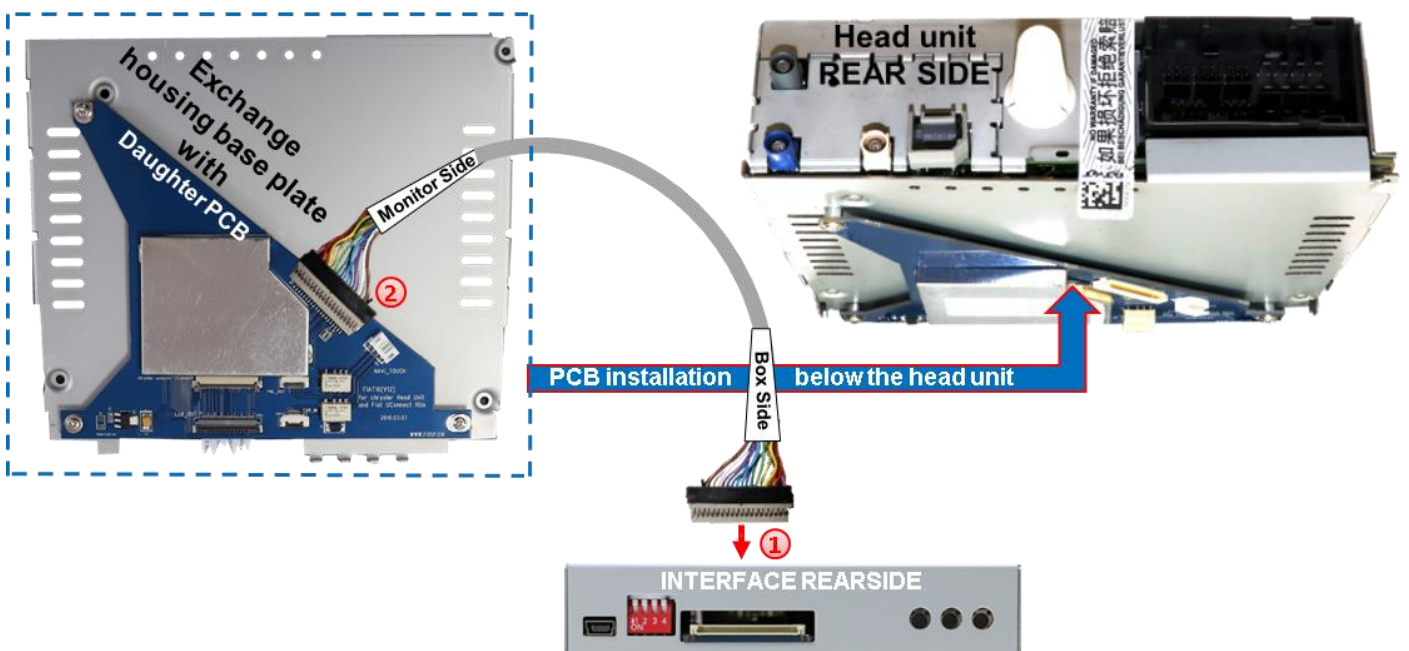

- 1 Connect the 20pin RGB digital cable's female 20pin connector to the male 20pin connector of the video-interface.
- 3 Connect the male beige-coloured 20pin connector of the 20pin RGB digital cable to the female 20pin connector of the daughter PCB.

Pay special attention to the cable's direction because its connectors both seem to be identical. (Strictly respect the labels „**MONITOR SIDE**“ and „**BOX SIDE**“).

2.6. Connection – PNP Quadlock harness

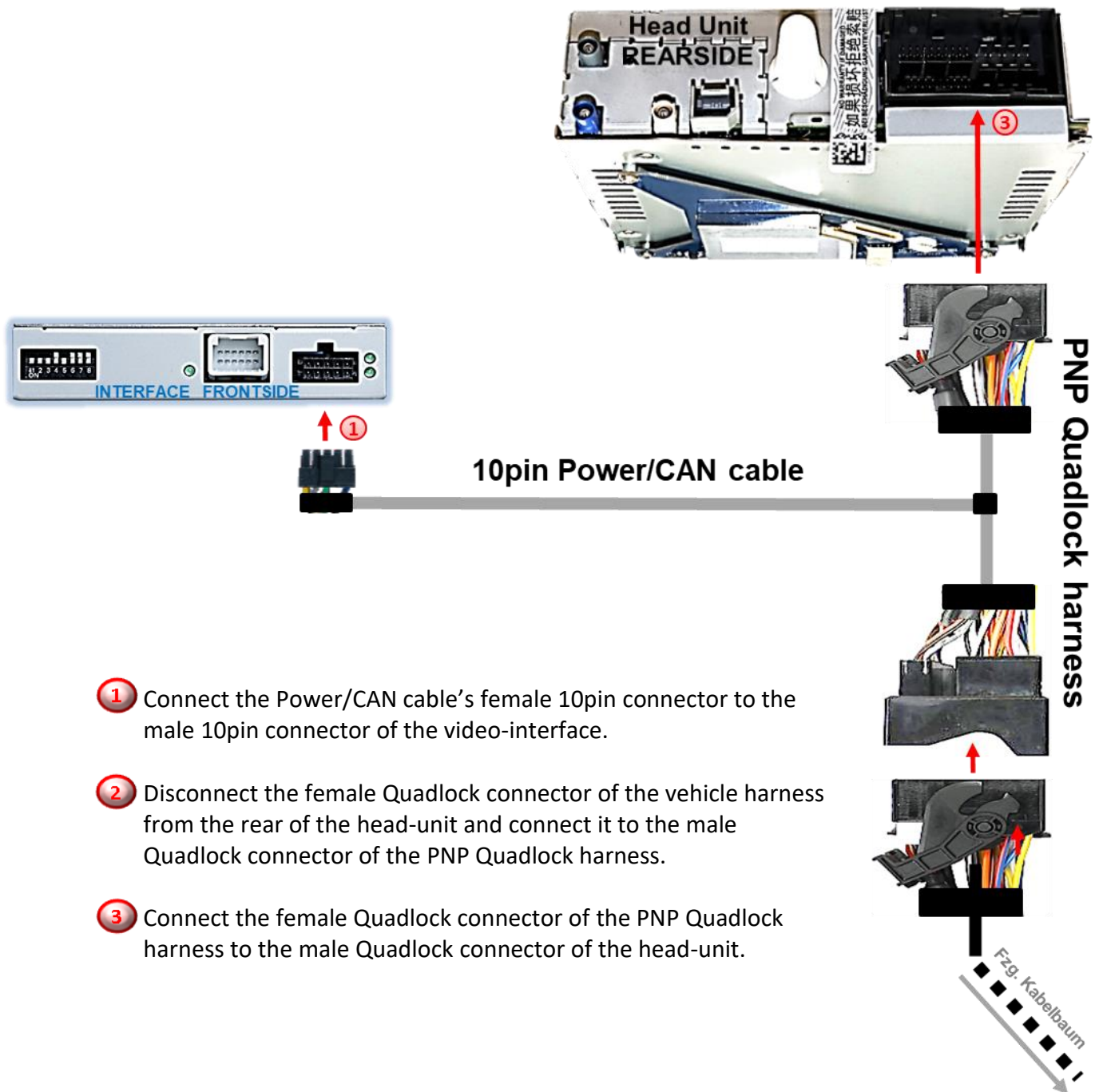

- 1 Connect the Power/CAN cable's female 10pin connector to the male 10pin connector of the video-interface.
- 2 Disconnect the female Quadlock connector of the vehicle harness from the rear of the head-unit and connect it to the male Quadlock connector of the PNP Quadlock harness.
- 3 Connect the female Quadlock connector of the PNP Quadlock harness to the male Quadlock connector of the head-unit.

Check 1

Exceptionally, the CAN communication may not succeed in all vehicles! If, after connecting the PNP harness, no interface LED lightens up while the ignition is turned on, additionally the analog power supply needs to be done! (see following chapter)

Check 2

Exceptionally, the power supply to the video interfaces may not be interrupted after switching to the vehicle's sleep mode. If the interface LEDs continue to shine even in the vehicle's sleep mode, please contact the support!

2.7. Analog power supply

If, after connecting the 20-Pin PNP harness, no interface LED lightens up while the ignition is turned on, the single purple coloured wire **Manual ACC** of the 12pin interface cable has to be connected additionally to **+12V S-contact terminal 86s** (e.g. glove compartment illumination).

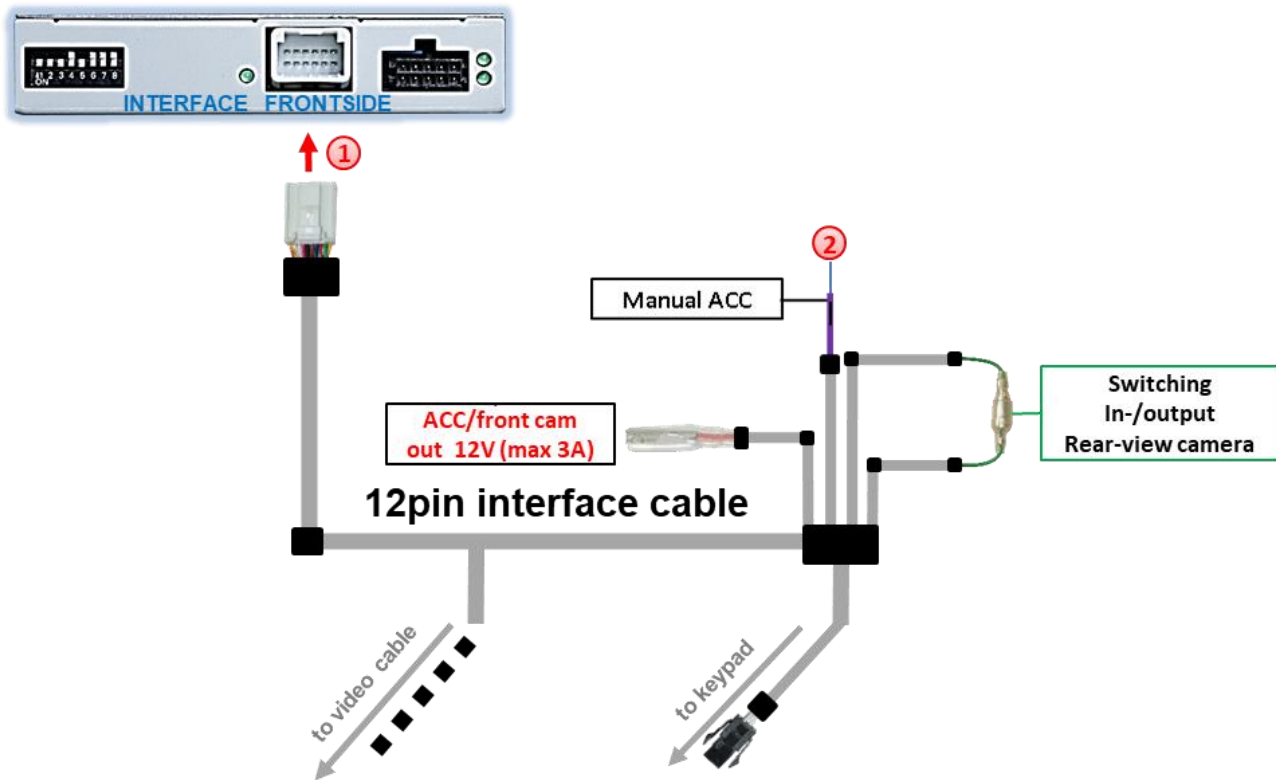

- 1 Connect the female 12pin connector of the 12pin interface cable to the male 12pin connector of the video interface.
- 2 Connect the 12pin interface cable's purple coloured wire **Manual ACC** to **S-contact terminal 86s +12V** (e.g. glove compartment illumination).

2.8. Power supply output

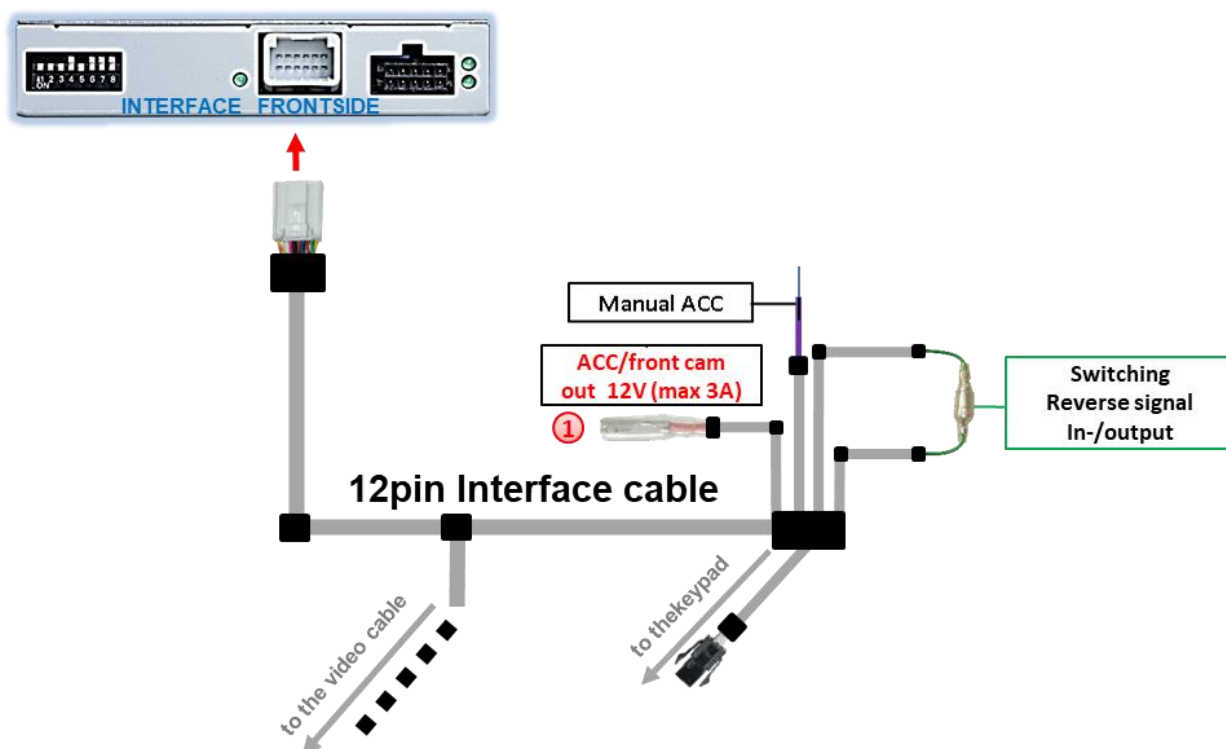

① The red power supply output **ACC/front cam out 12V (max 3A)** can be used to power an external source and has a different assignment depending on the position of dip switch 1 (of the black 8 dips):

Dip	Function
Dip 1 ON	+12V (max. 3A) when reverse gear is engaged incl. 10 seconds delay after reverse gear is disengaged and +12V by manual switching to front camera by keypad (short press)
Dip 1 OFF	+12V (max. 3A) ACC

2.9. Connecting Video sources

It is possible to connect an after-market rear-view camera, an after-market front camera and two more video sources to the video-interface.

Before the final installation, we recommend a test-run to detect a incompatibility of vehicle and interface. Due to changes in the production of the vehicle manufacturer there's always a possibility of incompatibility.

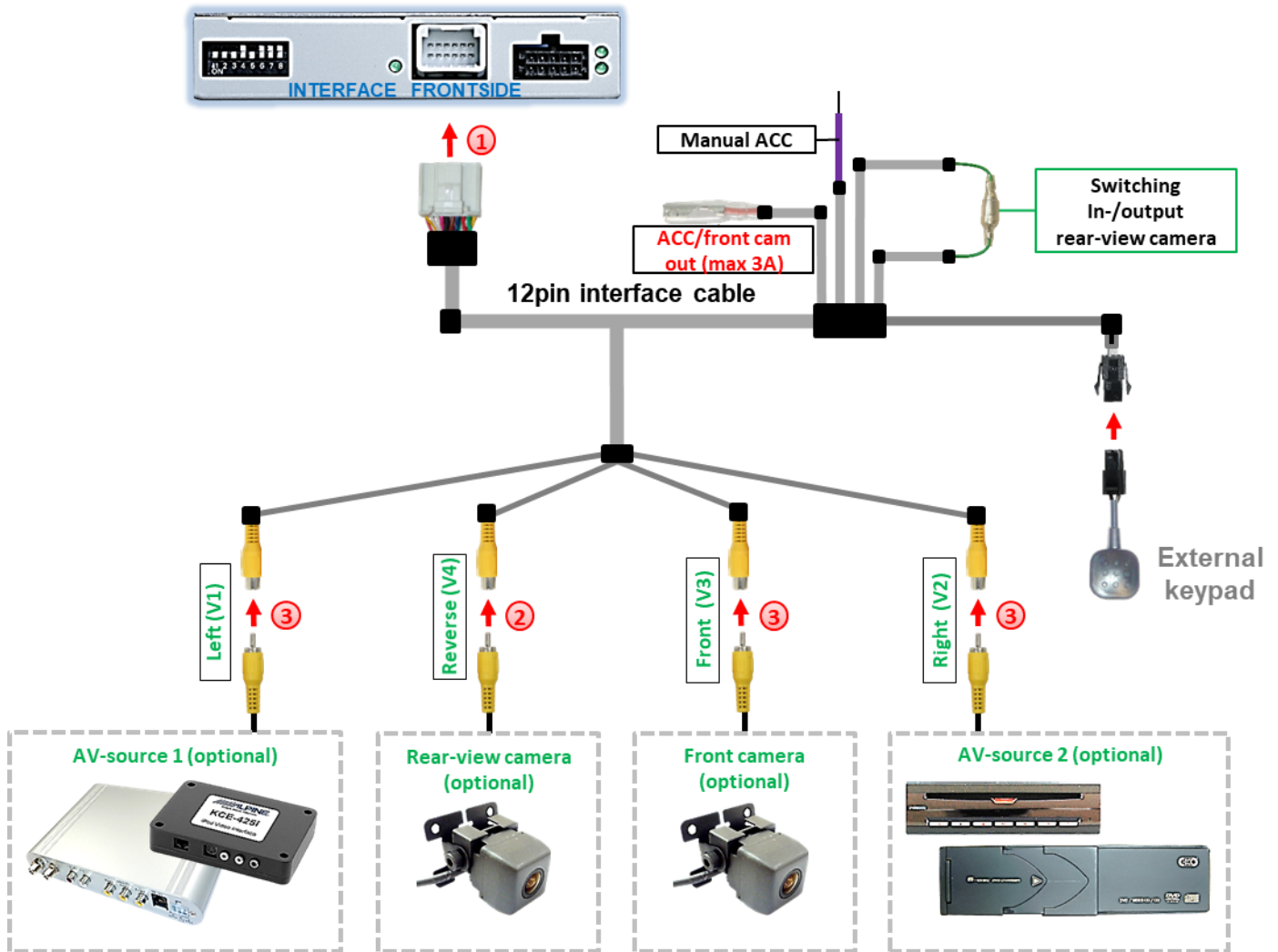

- ① Connect the 12pin interface cable's female 12pin connector to the male 12pin connector of the video-interface.
- ② Connect the video RCA of the Rear-view camera to the 12pin interface cable's female RCA connector „Reverse V4“.
- ③ Connect the front camera's video RCA connector to the 12pin interface cable's female RCA connector „Front V3“.
- ④ Connect the video RCA of the AV source 1 and 2 to the 12pin interface cable's female RCA connector “Left (V1)” and “Right (V2)”.

2.9.1. Audio-insertion

This interface is only able to insert video signals into the factory infotainment. If an AV-source is connected, the audio insertion has to be done by the factory audio AUX input or an FM-modulator. The inserted video-signal can be activated simultaneously to each audio-mode of the factory infotainment. If two AV sources shall be connected to the infotainment, additional electronic is necessary to switch the audio signals.

2.9.2. After-market front camera

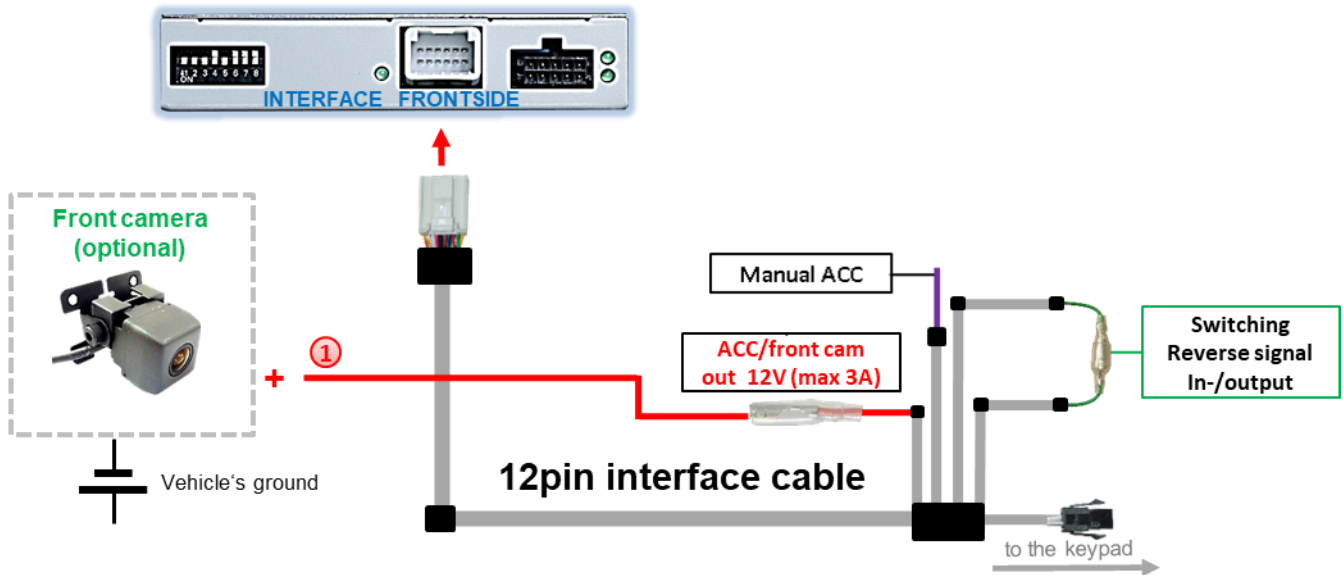

- 1 The red power supply output **ACC/front cam out 12V (max 3A)** can be used to power a front camera. If Dip 1 is set to ON (black 8 dips), the power supply output gives +12V (max 3A) when reverse gear is engaged incl. 10 seconds delay after reverse gear is disengaged.

Note: In addition, a manual switch-over to the front camera input is possible via keypad (short press) from any image mode. The power supply output gives +12V then, as well (if Dip 1 is set to ON and the front camera input is selected).

Attention: A long press of the external keypad push button will switch the interface to the next source.

2.9.3. After-market rear-view camera

Some vehicles have a different reverse gear code on the CAN-bus which the video-interface is not compatible with. Therefore, there are two different ways of installation. If the video interface receives a signal of the reverse gear, the green wire “Reverse-OUT” of the 20pin cable should carry +12V while the reverse gear is engaged.

Note: Do not forget to set dip5 of the video-interface to ON before testing.

2.9.3.1. Case 1: Video interface receives the reverse gear signal

If the CAN-bus interface delivers +12V on the green wire of the 20pin cable when reverse gear is engaged, it will automatically be switched to the rear-view camera input “Camera IN” while reverse gear is engaged.

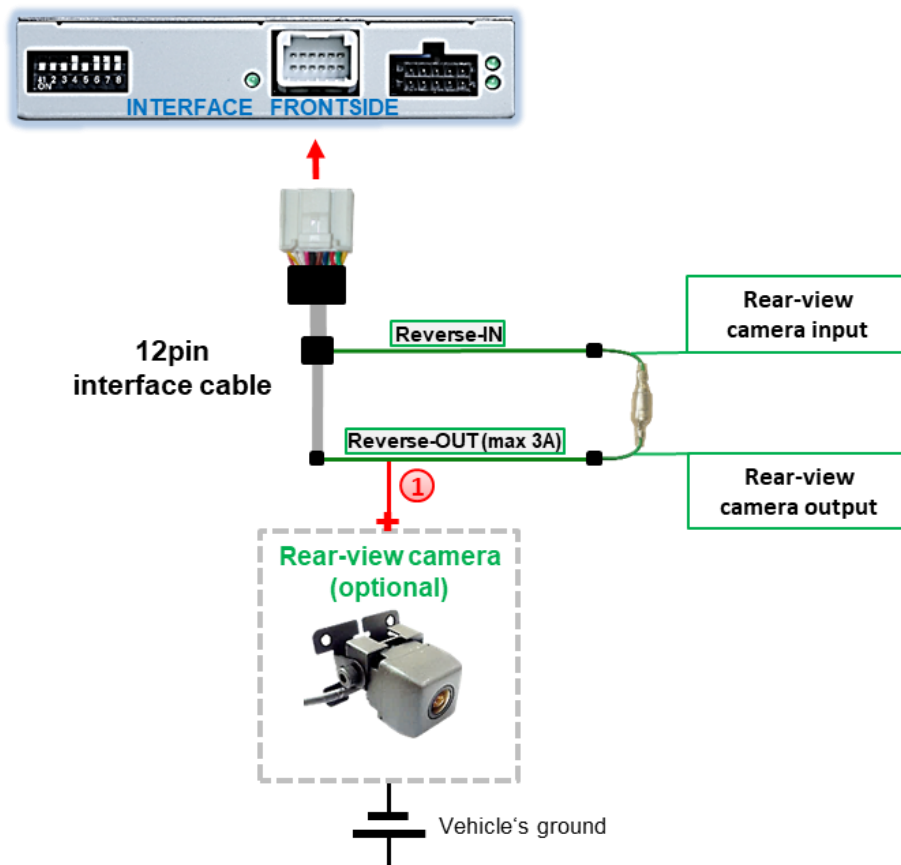

- 1 The 12 V power supply for the rear-view camera (max 3A) has to be taken from the green wire of the 20pin cable to avoid an unnecessary permanent power supply to the camera electronic.

For the operation, both green cables “Reverse IN” and “Reverse OUT” have to stay connected.

2.9.3.2. Case 2: Interface does not receive any reverse gear signal

If the video interface does not deliver +12V on the green wire of the 20pin cable when reverse gear is engaged (not all vehicles are compatible), an external switching signal from the reverse gear light is required. As the reverse gear light's power supply isn't voltage-stable all the time, an ordinary open relay (e.g AC-RW-1230 with wiring AC-RS5) or filter (e.g. AC-PNF-RVC) is required. The diagram below shows the connection type of the relay.

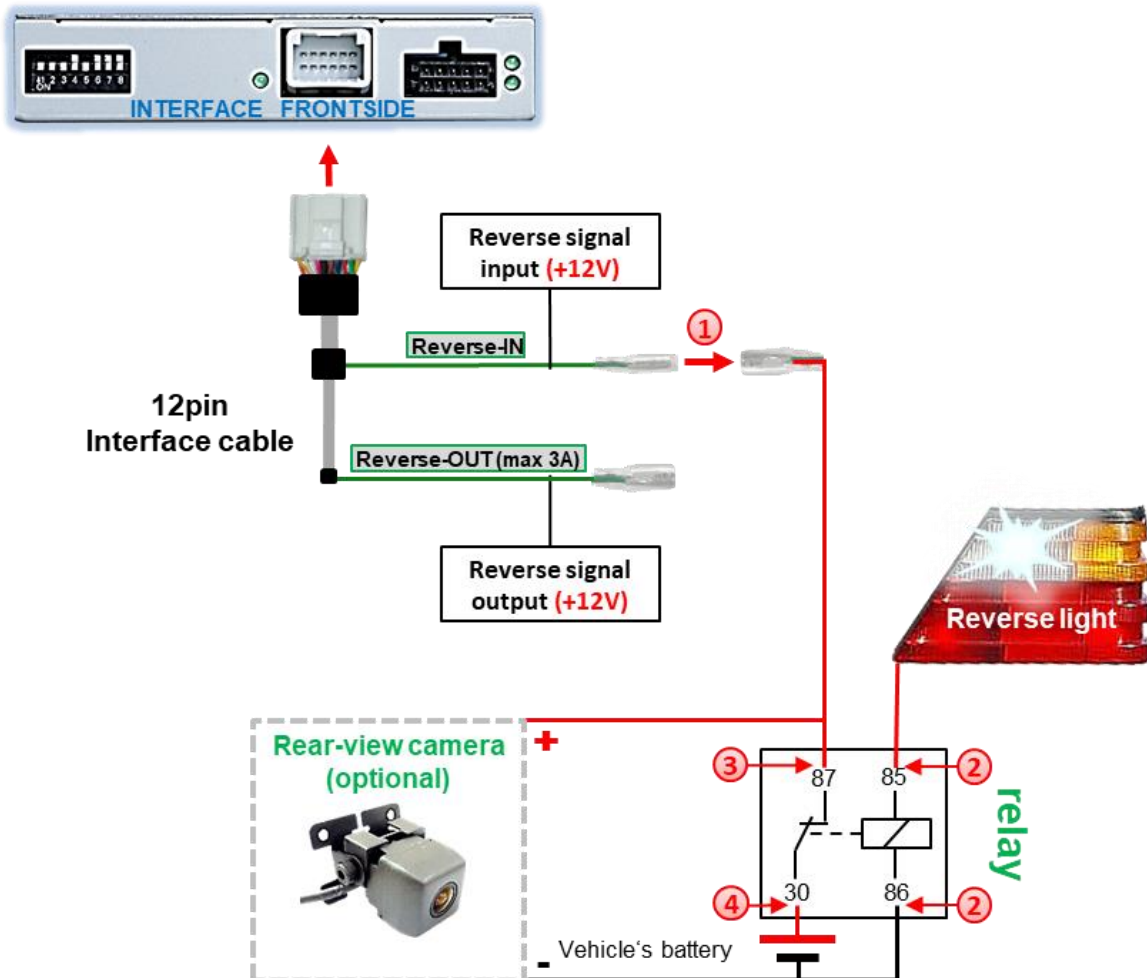

- ① Disconnect the green cable's pre-connected male- and female connectors of the 12pin cable and connect the green input cable "Reverse-IN" to the output connector (87) of the relay.

Note: Not least to avoid short circuits, the best solution should be, to crimp a male 4mm connector to the relay's output cable and connect it to the green cable's female 4mm connector. The output-cable "Reverse-OUT" remains disconnected as it's out of function.

- ② Connect the Reverse light's power-cable to coil (85) and the vehicle's ground to coil (86) of the relay.
- ③ Connect the output connector (87) of the relay to the rear-view camera's power-cable, like you did it to the green "Reverse-IN" cable before.
- ④ Connect permanent power / 12V to the relay's input connector (30).

2.10. Connection - external keypad

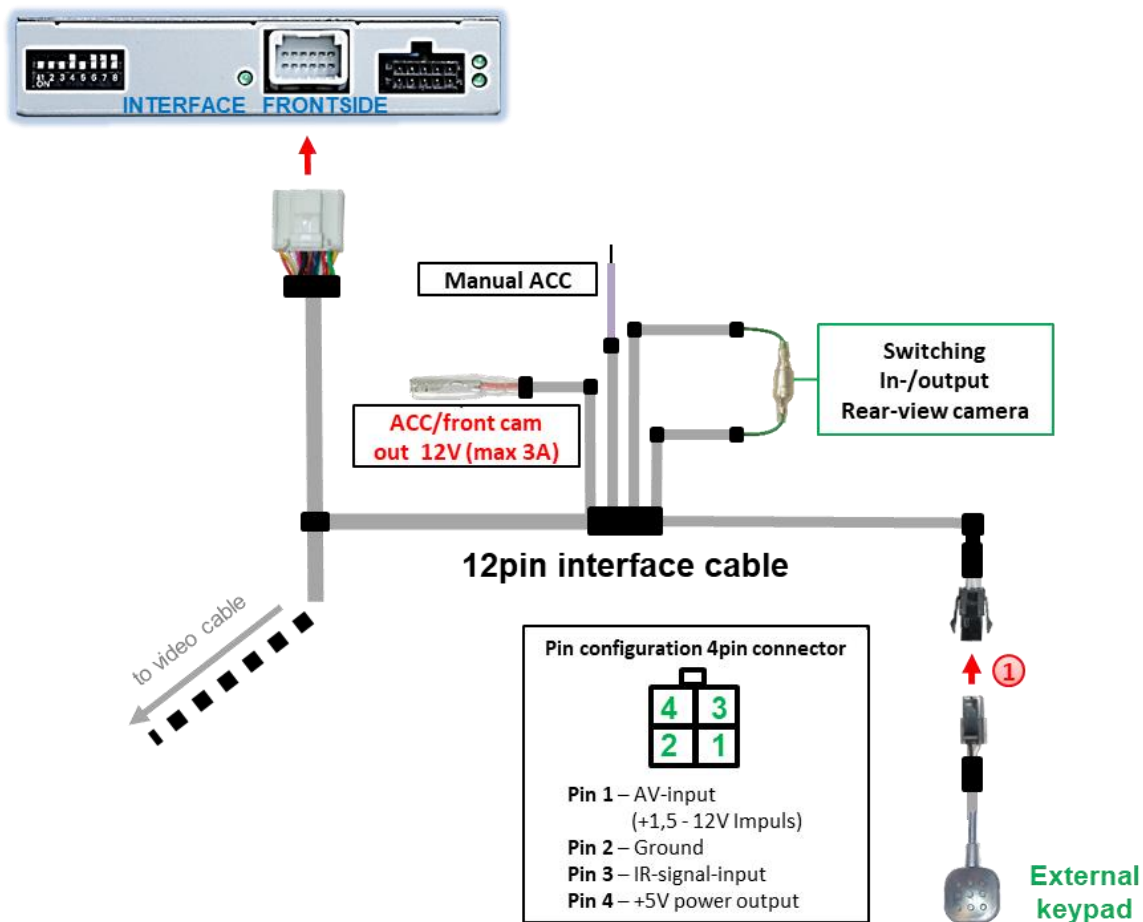

- 1 Connect the keypad's female 4pin connector to the 12pin interface cable's male 4pin connector.

Note: Even if the switching through several video sources by the keypad mightn't be required, the keypad's invisible connection and availability is strongly recommended.

3. Interface operation

The interface's external keypad can be used to switch the enabled inputs.

➤ Long press of keypad (2-3 seconds)

By long pressing the external keypad (2-3 seconds), the video interfaces switches the input from the factory video to the inserted video sources.

Each press (approx. 2 sec) will switch to the next enabled input. If all inputs are enabled the order is:

Factory video → video IN1 → video IN2 → factory video →...

By dip switch deactivated inputs will be skipped. If an audio switch has been connected in the system, also the audio signal will be switched when switching from video IN1 to video IN2

Note: The interface switches after releasing the switch (after long pressure).

➤ Short press of keypad (only if DIP 1 is set to ON)

By short pressing the external keypad, the video interfaces switches from the factory video to the front camera input and back to factory video.

3.1. Picture settings

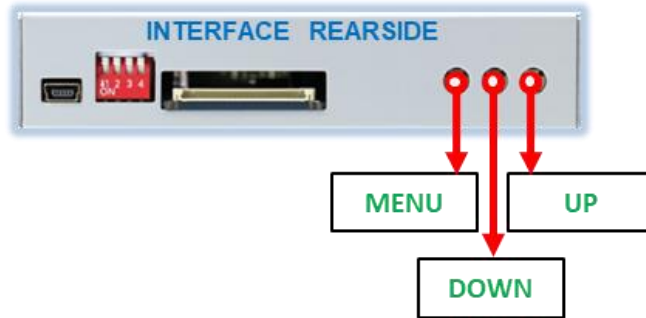

The picture settings can be adjusted by the 3 buttons on the video-interface. Press the **MENU** button to open the OSD settings menu. To switch to the next menu item, pressing **UP** and **DOWN** will change the selected value. The buttons are embedded in the housing to avoid accidental changes during or after installation. The picture settings have to be done separately, AV1 and AV2 while the corresponding input is selected and visible on the monitor.

Note: The OSD menu is only shown when a working video source is connected to the selected video-input of the interface.

The following settings are available:

- Contrast
- Brightness
- Saturation
- Position H (horizontal picture position)
- Position V (vertical picture position)
- IR-AV1 (out of function)
- IR-AV2 (out of function)
- Guide-L (out of function)
- Guide-R (out of function)
- UI CNRTL (ON/OFF) (out of function)
- H-SIZE (horizontal picture size)
- V-SIZE (vertical picture size)

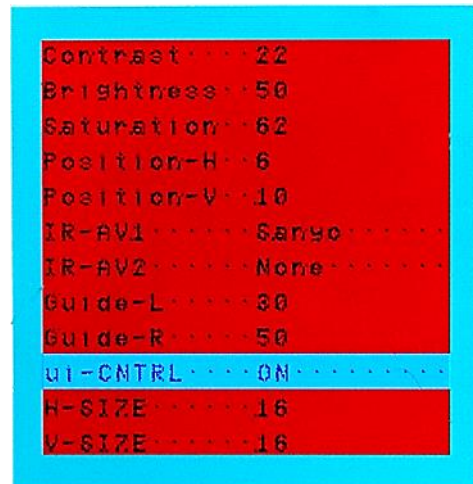

Note: If the CAN-box does not support the vehicle's CAN, the guide-lines cannot be used.

4. Specifications

BATT/ACC range	7V - 25V
Stand-by power drain	3,6mA
Power	112mA @12V
Video input	0.7V – 1V
Video input formats	NTSC
RGB-video amplitude	0.7V with 75 Ohm impedance
Temperature range	-40°C to +85°C
Dimensions Video-Box	115 x 25 x 89 mm (W x H x D)

5. FAQ – Trouble shooting Interface functions

For any troubles which may occur, check the following table for a solution before requesting support from your vendor.

Symptom	Reason	Possible solution
No picture/black picture (factory picture).	Not all connectors have been reconnected to factory head-unit or monitor after installation.	Connect missing connectors.
	No power on CAN-bus box (all LED CAN-bus box are off).	Check power supply of CAN-bus box. Check CAN-bus connection of CAN-bus box.
	CAN-bus box connected to CAN-bus in wrong place.	Refer to the manual where to connected to the CAN-bus. If not mentioned, try another place to connect to the CAN-bus.
	No power on video-interface (all LED video-interface are off).	Check whether CAN-bus box delivers +12V ACC on red wire output of 8pin to 6pin cable. If not cut wire and supply ACC +12V directly to video-interface.
No picture/black picture/white picture (inserted picture) but factory picture is OK.	No picture from video source.	Check on other monitor whether video source is OK.
	No video-source connected to the selected interface input.	Check settings dips 1 to 3 of video interface which inputs are activated and switch to corresponding input(s).
	LVDS cables plugged in wrong place.	Double-check whether order of LVDS cables is exactly connected according to manual. Plugging into head-unit does not work when the manual says to plug into monitor and vice versa.
Inserted picture totally wrong size or position.	Wrong monitor settings of video-interface.	Try different combinations of dips 7 and 8 of video-interface. Unplug 6pin power after each change.
Inserted picture double or 4 times on monitor.		
Inserted picture distorted, flickering or running vertically.	Video sources output set to AUTO or MULTI which causes a conflict with the interfaces auto detection.	Set video source output fixed to PAL or NTSC. It is best to set all video sources to the same standard.
	If error occurs only after source switching: Connected sources are not set to the same TV standard.	Set all video sources to the same standard.
	Some interfaces can only handle NTSC input.	Check manual whether there is a limitation to NTSC mentioned. If yes, set source fixed to NTSC output.
Inserted picture b/w.	Picture settings have not been adjusted.	Use the 3 buttons and the interface's OSD to adjust the picture settings for the corresponding video input.
Inserted picture qual. bad.		
Inserted picture size slightly wrong.		
Inserted picture position wrong.		
Camera input picture flickers.	Camera is being tested under fluorescent light which shines directly into the camera.	Test camera under natural light outside the garage.
Camera input picture is bluish.	Protection sticker not removed from camera lens.	Remove protection sticker from lens.

Symptom	Reason	Possible solution
Camera input picture black.	Camera power taken directly from reverse gear lamp.	Use relay or electronics to "clean" reverse gear lamp power. Alternatively, if CAN-bus box is compatible with the vehicle, camera power can be taken from green wire of 6pin to 8pin cable.
Camera input picture has distortion.		
Camera input picture settings cannot be adjusted.	Camera input picture settings can only be adjusted in AV2 mode.	Set dip 3 of video-interface to ON (if not input AV2 is not already activated) and connect the camera to AV2. Switch to AV2 and adjust settings. Reconnect camera to camera input and deactivate AV2 if not used for other source.
Graphics of a car in camera input picture.	Function PDC is ON in the interface OSD.	In compatible vehicles, the graphics will display the factory PDC distance. If not working or not wanted, set interface OSD menu item UI-CNTRL to ALLOFF.
Chinese signs in camera input picture	Function RET or ALL is ON (function for Asian market) in the interface OSD.	Set interface OSD menu item UI-CNTRL to ALLOFF or PDCON.
Not possible to switch video sources by OEM button.	CAN-bus interface does not support this function for vehicle.	Use external keypad or cut white wire of 6pin to 8pin cable and apply +12V impulses for AV-switching.
Not possible to switch video sources by external keypad.	Pressed too short.	For video source switching a longer press of about 2.5 seconds is required.
	SW-version of interface does not support external keypad.	Use OEM-button or cut white wire of 6pin to 8pin cable and apply +12V impulses for AV-switching.
Interface does not switch to camera input when reverse gear is engaged.	CAN-bus interface does not support this function for the vehicles.	Cut the green wire of the 6pin to 8pin cable and apply +12V constant from reverse gear-lamp signal. Use relay to "clean" R-gear lamp power.
Interface switches video-sources by itself.	CAN-bus interface compatibility to vehicle is limited.	Cut the grey wire of 6pin to 8pin and isolate both ends. If problem still occurs, additionally cut the white wire of 6pin to 8pin cable and isolate both ends.

6. Technical Support

Please note that direct technical support is only available for products purchased directly from NavLinkz GmbH. For products bought from other sources, contact your vendor for technical support.

NavLinkz GmbH
distribution/tech dealer-support
 Heidberghof 2
 D-47495 Rheinberg

Tel +49 2843 17595 00
 Email mail@navlinkz.de

 10R-05 0068

Made in China

