

**STROKER
STROKER PRO
SPEAKERS**

**SERIES
SERIES**



ST65C / SPR065C

USER MANUAL

MAKING IT LOUD SINCE 1954!

Cerwin Vega Mobile Speakers

Congratulations for purchasing Cerwin Vega Mobile speakers for your car audio system. You have chosen Cerwin Vega Mobile because you deserve the best!

Cerwin Vega Mobile speakers are designed and engineered to reproduce great sound quality for many years of listening enjoyment in your vehicle!

We highly recommend that your new speakers be installed by an authorized Cerwin Vega Mobile dealer. Your authorized dealer can professionally assemble/disassemble the interior of your vehicle and set the proper speaker placement for ideal sound quality.

If you decide to install the speakers by yourself, please thoroughly read through this manual before getting started. This manual will help familiarize yourself with these speakers and guide you through the installation process and procedures.

Please contact your local authorized Cerwin Vega Mobile dealer if you have any questions regarding the instructions in this manual. If you require additional assistance, please contact the Cerwin Vega Mobile Technical Support Department during business hours at 213.261.4161

Installation

Installing the Speakers

Your new Cerwin Vega Mobile series speakers were designed with the flexibility to be installed in multiple locations. However, to ensure the best performance possible, it is important to isolate the front sound waves of the speaker from its rear sound waves. This is done by securely mounting the speaker to a flat surface known as a baffle. Make sure to seal the speaker to ensure there are no air leaks around its frame.

Selecting a Location

If your vehicle has existing factory locations, the easiest method would be to replace them with the exact same size speaker. In the case where there is not a factory speaker location, there are many places where the speakers will fit in a vehicle, but they are not always the best locations for good sound. Make sure to take the time to select the best locations possible.

Mounting the speakers so that they are equal distance from your ears will achieve the best results. If you experience any difficulties, please consult with your local authorized Cerwin-Vega Mobile dealer. They have the tools and know-how to help

Door Mounting (if not using factory locations)

Prior to cutting, remove the panel from the door and check for clearance in the in the intended installation area, making sure the window will go all the way up and down without any interference. Avoid cutting any structural metal support or braces to mount the speakers. We HIGHLY recommend that for the BEST sound you put a sound deadening mat on the door "skin" (as shown below). The more "damped" your car is.... the better it will ultimately sound!!!

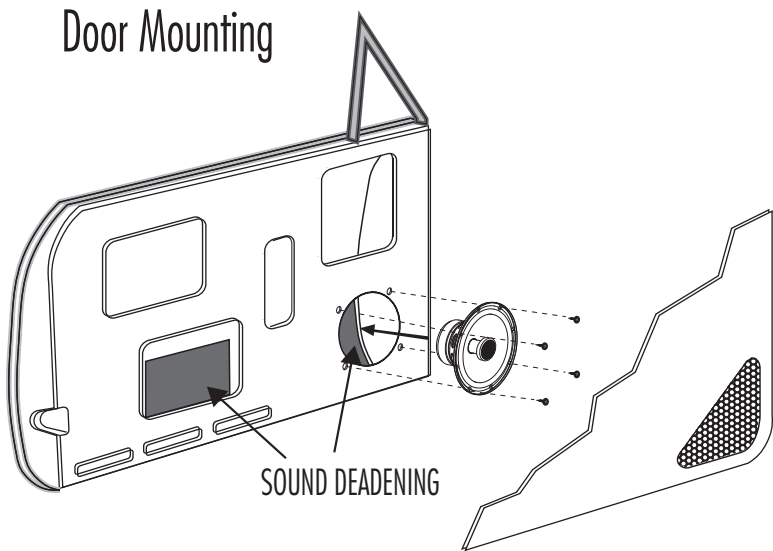

Installation

Rear Deck Mounting

There are two primary methods for mounting speakers in the rear deck of a vehicle, top and bottom mounting. Top mounting requires dropping the speakers in through the deck (interior) while bottom mounting secures the speakers from underneath (trunk). Either method requires a good seal around the frame for the best performance.

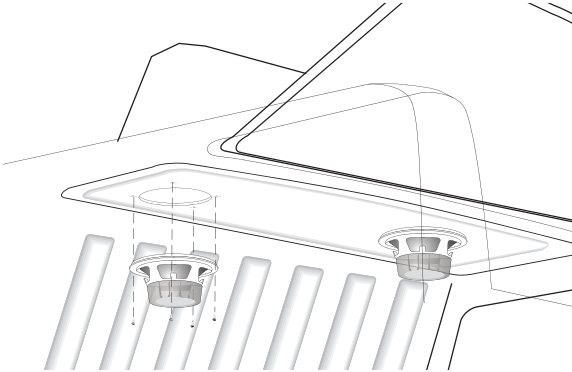

Running New Wiring

In most cases when mounting new speakers you will use the factory supplied wiring, but if new wires have to be run there are some precautions that need to be taken. If the wire needs to run through metal, such as a door jamb, always use a grommet to prevent damage to your wires. Never run wire through bare metal! This can damage the source unit, amp, or even the speakers themselves. Safety of the wiring against short circuits is **THE MOST IMPORTANT INSTALLATION CONCERN**.

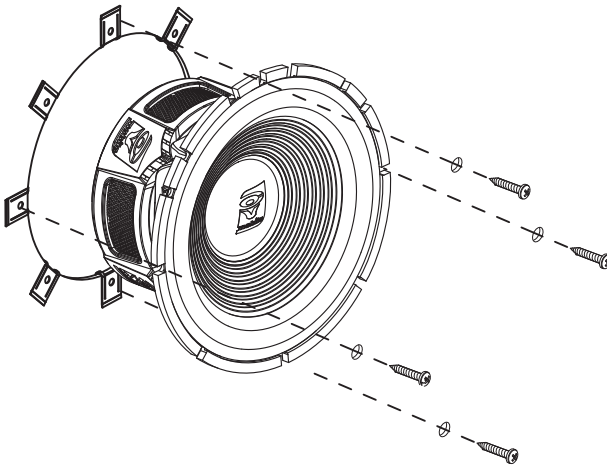

Installation

The illustration below shows how to connect one channel of the ST65C component system (SPRO65C is same in connection)

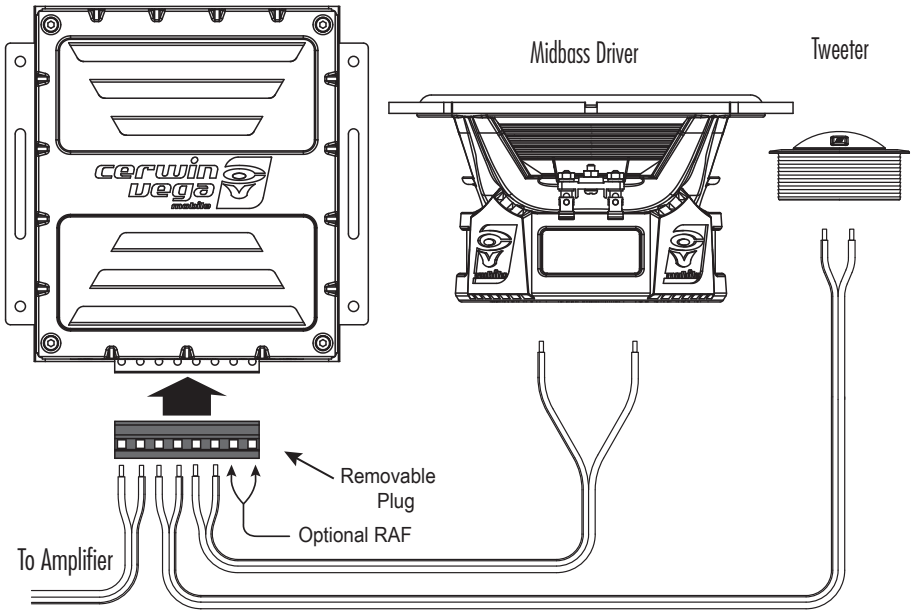

Crossover Programing

Each ST65C / SPRO65C component system comes with a pair of model specific adjustable crossovers giving you attenuation and phase adjustments. The tweeter adjustment has settings for -2dB of attenuation, 0dB or +2dB of gain. There is also a "Phase switch" that you may use in different application/locations to correct for acoustical phase issues casued by placement of the drivers in the vehicles particular enviroment.

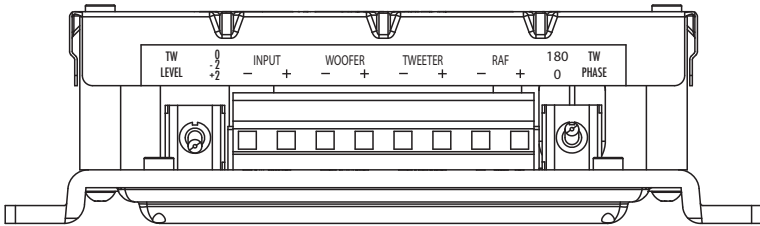

Tweeter Installation

When flush or surface mounting tweeters, make sure desired location can accommodate the hole sizes and depth required. Mount cup using provided hardware, flush mount illustration shown below. Mount surface cup with provided screws in tweeter mounting kit. Snake speaker wires through tweeter cup, connect tweeter to wires and snap tweeter into cup by pushing down gently. Be careful not push on the center of the tweeter grill.

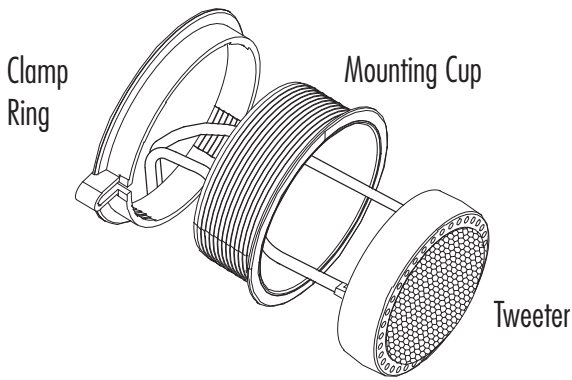

Crossover Installation

Install in a well ventilated area whenever possible. If you must install the passive crossovers in the doors due to the use of factory wiring. As you “feed” into the door cavity, ensure that the crossover is installed behind the door panel instead of inside the door itself. This will offer the greatest capacity for avoiding any water damage caused by rain or moisture. Also avoid placing it near factory wiring looms to ensure no radiated noise problems. Connect the input side labeled “INPUT” of each passive crossover to the amplifier’s speaker output terminals. Be sure to observe correct polarity for positive and negative terminals. Next, connect the middle terminals labeled “WOOFER” to the midrange speaker. Be sure that the wiring is protected all the way to the terminal and that the wires are secure at both the speaker and passive crossover. Finally, connect the end terminals labeled “TWEETER” to the tweeter. Be careful to observe the correct polarity when connecting the tweeter to its lead wires as these are smaller gauge and require care and patience to connect correctly. Each ST65C or SPRO65C component crossover has a third set of outputs marked “RAF”. This stands for Rear Acoustic Fill. This output can be used to power an additional speaker off the same channel without effecting the impedance load on the source unit. The level of this output is pre-determined at -10dB of attenuation, for a REAL “rear fill” This creates a much more real stereo image and a bigger sound stage.

SPR065C

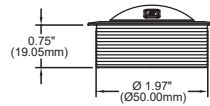
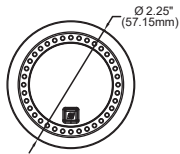
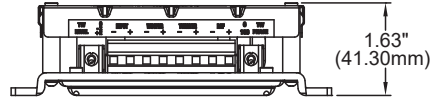
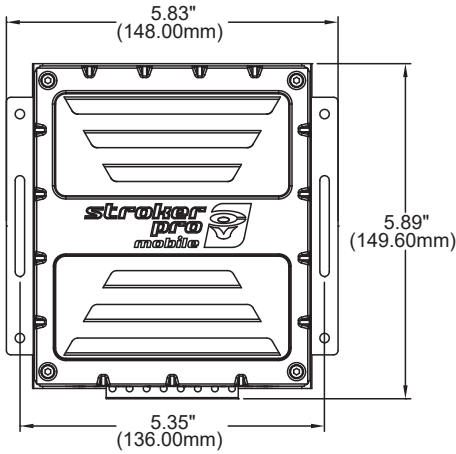
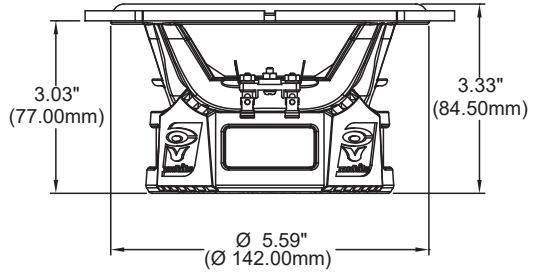
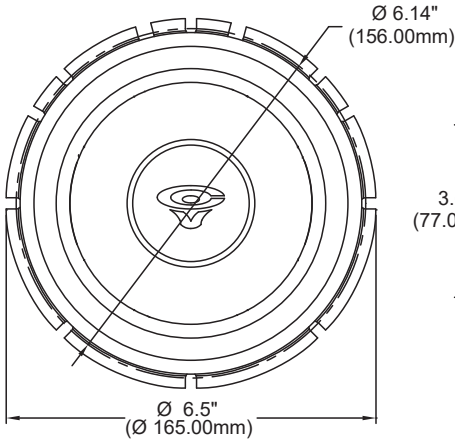

ST65C

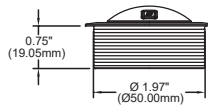
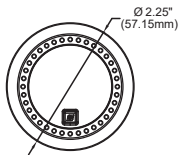
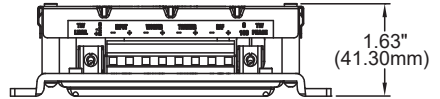
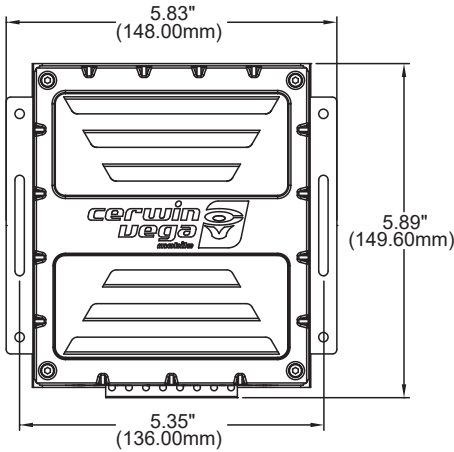
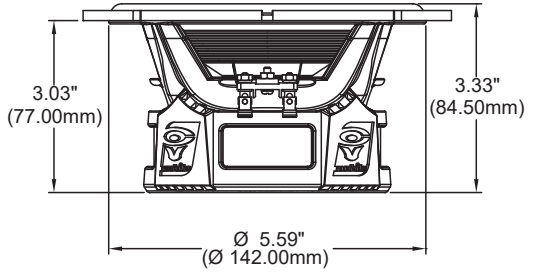
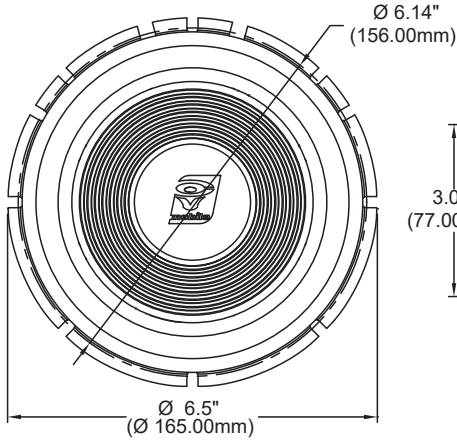

Specifications

| MODEL | TYPE | POWER HANDLING |
|--------------|------------------------------------|------------------------------------|
| ST65C | 6.5" 2-way component speaker set - | 250W MAX / 125W RMS POWER HANDLING |
| SPRO65C | 6.5" 2-way component speaker set - | 350W MAX / 175W RMS POWER HANDLING |

Warranty

Thank you for purchasing a Cerwin Vega Mobile product and we hope to provide you with countless hours of listening enjoyment.

Please take a brief moment to register your new product. By registering your new product, you will receive benefits such as:

- Important product notifications that may pertain to your purchase.
- Confirmation and record of ownership in case of loss or theft.
- Knowledgeable customer service and technical assistance pertaining to your product.

Register your new product by completely filling out this Product and Warranty Registration card or register online at www.cerwinvegamobile.com.

Registration is voluntary and failure to register will not diminish your limited warranty rights.

Limited Warranty (U.S.A.)

Cerwin Vega Mobile warrants all of our amplifiers and speakers to be free of defects in materials and workmanship for a period of one (1) year.

This warranty is non-transferable and applies only to the original purchaser from an authorized Cerwin Vega Mobile dealer. If service is required and necessary under this warranty due to manufacturing defect or malfunction, then Cerwin Vega Mobile will repair and/or replace defective product with either new or remanufactured like product at no charge at our discretion.

Damage to product caused by the following will not be covered under this warranty: abuse, accident, misuse, neglect, modifications, repairing attempts, seller/installer misrepresentation.

This warranty does not cover any incidental, consequential, or cosmetic damage due to accidents or normal wear and tear, nor does it cover the cost of removing or reinstallation of the product.

Warranty is void if the product's serial number has been removed, defaced, and/or tampered with.

Warranty Procedure:

We recommend that you contact your Cerwin Vega Mobile authorized dealer where your original purchase was made to initiate all warranty claims. Our authorized dealers can guide you through the warranty procedure to ensure that your claim will be processed in a timely manner. All warranty returns must be accompanied with a proof of purchase (a copy of the original sales receipt) and be shipped freight prepaid to our facility with an RA (Return Authorization) number clearly marked on the outside of the package. Direct returns from consumers or non-authorized dealers will be refused if shipped without a valid RA number authorized by Cerwin Vega Mobile beforehand.

INTERNATIONAL

Products purchased outside of the U.S.A. are covered only by that country's distributor and not by Cerwin Vega Mobile U.S.A.

Please Ship All Warranty Claims With Pre-Authorized RA Number To:

CV&DA Holdings, Inc.

ATTN: Customer Service Department

1225 E. 7th St.

Los Angeles, CA 90021 USA

Please Contact Customer Service for Further Warranty Information:

U.S.A.

Tel: 213-261-4161 / Fax: 213-947-4767



1225 E. 7th St. • Los Angeles, CA 90021 USA

P 213-261-4161 • F 213-947-4767

WWW.CERWINVEGAMOBILE.COM

©2014 Cerwin Vega Mobile. All rights reserved.
(a division of CV & DA Holdings, Inc.)