

cerwin
vega
mobile 

STROKER PRO
CLASSIC
SUBWOOFER

SPCL152/SPCL182

USER MANUAL

Cerwin Vega Mobile Subwoofers

Congratulations for purchasing the Stroker Pro Classic, Cerwin-Vega Mobile's uncompromising achievement in ultimate low-frequency power response. Based on the legendary and SPL competition-winning Stroker™ series subwoofers, Stroker Pro Classic incorporates the heritage and design elements of its predecessor with modern and innovative technologies. As a result, expect extreme performance as you take it to the limit! You are passionate about car audio and will only settle for the best...the Stroker Pro Classic!

Cerwin Vega Mobile subwoofers are designed and engineered to reproduce great sound quality for many years of listening enjoyment in your vehicle! We highly recommend that your new subwoofers be installed by an authorized Cerwin Vega Mobile dealer. Your authorized dealer can professionally assemble/disassemble the interior of your vehicle and recommend the proper enclosure design and set the proper subwoofer placement for ideal sound quality. If you decide to install the subwoofer(s) by yourself, please thoroughly read through this manual before getting started.

This manual will help familiarize yourself with these subwoofers and guide you through the installation process and procedures.

Please contact your local authorized Cerwin Vega Mobile dealer if you have any questions regarding the instructions in this manual. If you require additional assistance, please contact the Cerwin Vega Mobile Technical Support Department during business hours at 213-261-4161.

Specifications

Dimension	Unit	SPCL152	SPCL182
Total Diameter (A)	in. (mm)	15.5" (394mm)	18.1" (460mm)
Mounting Diameter (B)	in. (mm)	13.85" (352mm)	16.54" (420.5mm)
Screw Hole Dia. (C)	in. (mm)	0.33" (8.5mm)	0.27" (7mm)
Mounting Depth. (D)	in. (mm)	8.15" (207mm)	9.4" (239mm)
Hole Dia. (E)	in. (mm)	13.9" (354mm)	16.6" (422mm)
Displacement (ft ³ /L)		0.183 ft ³ (5.2L)	0.197 ft ³ (5.6L)

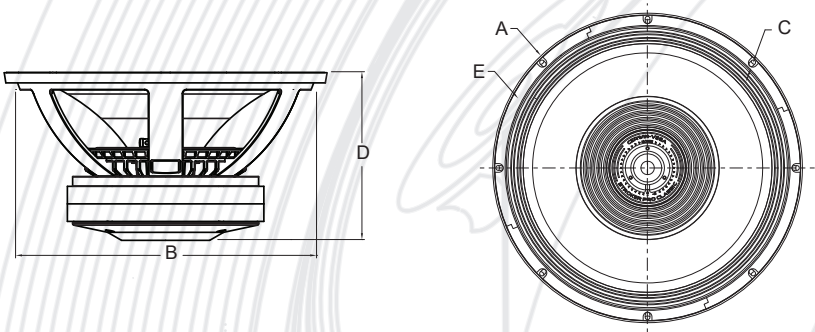

Thiele/Small Parameters

Parameter (unit)	SPCL152	SPCL182
SPL (dB)	93.8	95.0
Re (Ω)	1.68	1.68
Qms	16.0	19.0
Qes	0.35	0.39
Qts	0.34	0.38
Fs (Hz)	44.0	40.5
Vas (L)	62.0	117.0
Cms (mm/N)	0.06	0.06
Mms (g)	232	281
Sd (sq. cm)	881	1225
BL (T*M)	17.6	17.6
Xmax (mm)	24.0	24.0
Pwr (W) NOM/MAX	1200/2400	1600/3200

SPCL152 - 15 INCH SUBWOOFER SPCL182 - 18 INCH SUBWOOFER

- Heavy Duty Industrial Cast Aluminum Basket
- Advanced VC Heat Sink Design For Better Heat Dissipation
- 4" Single Layer High Temp Voice Coil With Black Coated VC former
- Detented Adjustable VC Xmax Control for Precise Tuning +/-15 Percent in 5% increments
- Elevated Motor Structure Cooling Design
- High Density, High B/L Motor Structure For High Power Handling
- Patent Pending Design
- Klippel DA Optimized Motor and Suspension Symmetry

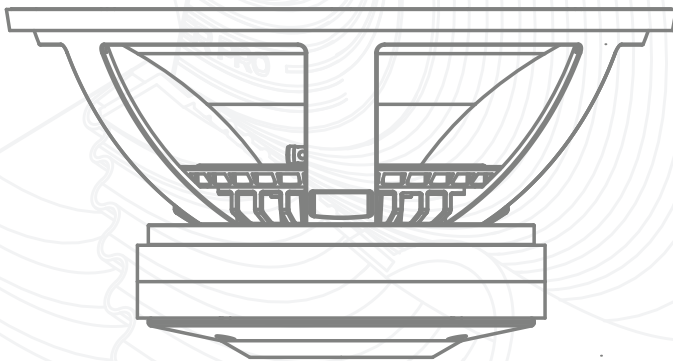

WOOFER BREAK-IN? SUPER IMPORTANT FOR BEST PERFORMANCE!

Giving your new subwoofer a few hours of break in will let the spiders loosen up and allow for higher excursion and the ability to play lower frequencies. Along with your T/S parameters changing once the woofer is fully broken in, you are less likely to damage the coil as it will move more freely in the gap which allows for better cooling and less build up of heat. All GOOD things!!!!

VC Bias Adjustment procedure

Step 1: Release 3 Top Set-Screws



Step 2: Release Center Set-Screw

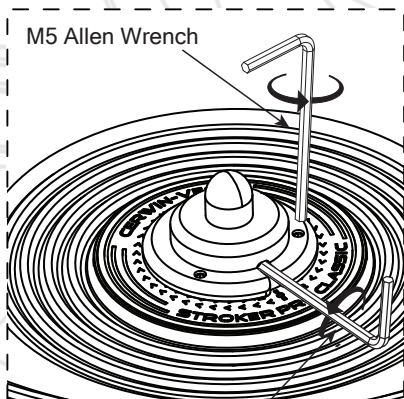
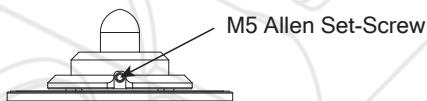

Step 3: Rotate Phase Plug

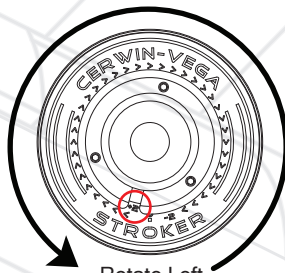
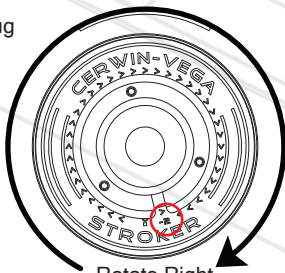
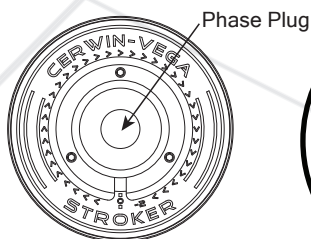

OR

NOTE: MAX Rotation is 300 degrees!!!

Step 4: Tighten Allen Set-screw

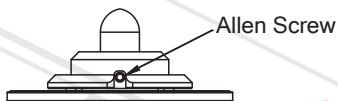

VC adjustment changes the subwoofer from a centered voice coil to an "Over-hung" or "Under-hung" voice coil.

NOTE: IF YOU DONT KNOW WHAT "OVERHUNG" OR "UNDERHUNG" VOICE COIL MEANS - THEN DONT TOUCH THIS ADJUSTMENT!!

Step 5: Tighten 3 Top Allen Set-Screws

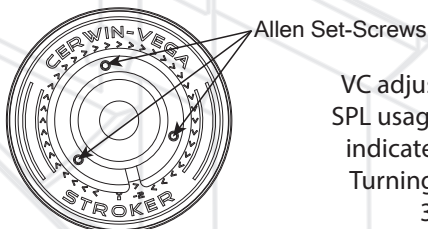

VC adjustment should only be used for professional SPL usage. It should not be adjusted further than the indicated 2mm. Failure to do so will void warranty. Turning the VC adjustment all the way down (over 300 degrees) could cause bottoming

RECOMMENDED ENCLOSURES

SUBWOOFER SIZE		PORTED ENCLOSURE		
(All measurements are calculated (Using 1" MDF))		Enclosure External Dimensions Width x Height x Depth W _{ext} x H _{ext} x D _{ext}	Slot Port Internal Dimensions Port Width x Port Height x Port Length P _{ort} W _{id} th x P _{ort} H _{eight} x P _{ort} Length	Port Extension Length "PE"
SPCL152	3.5 ft ³ 99.1 litres	30" x 20" x 14" 762mm x 508mm x 356.6mm	3" x 18" x 19.75" 76.2mm x 457.2mm x 501.65mm	9.25" (234.95mm)
SPCL182	4.6 ft ³ 130.25 litres	34.5" x 22.5" x 13.75" 876.3mm x 571.5mm x 349.25mm	3.5" x 20.5" x 19" 88.9mm x 420.7mm x 482.6mm	9.5" (241.3mm)

****NOTE: DO NOT even THINK about a sealed enclosure for this woofer!!!****
(if you want to use a sealed enclosure....buy a different woofer!!!)

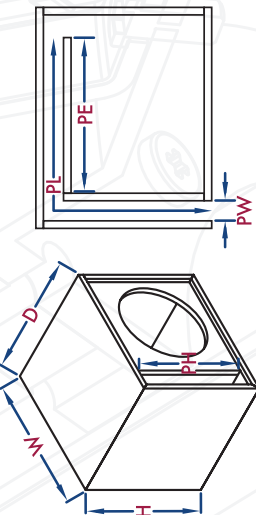
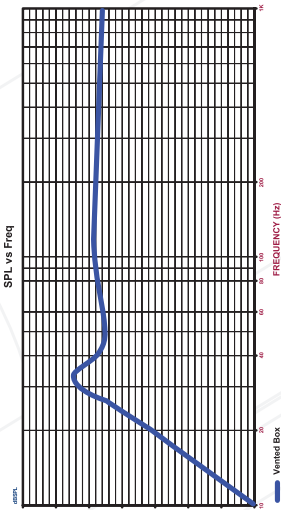

CAUTION

(The use of a sub-sonic filter set at a minimum of 30Hz is recommended on all vented enclosures.)

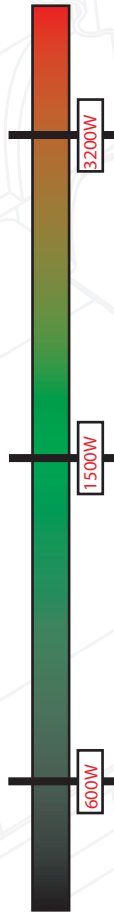

MINIMUM RMS POWER (600W BLACK AREA)
This lower amount of power will increase the longevity of the woofer, but will decrease the amount of output volume.

RECOMMENDED RMS POWER (1500W GREEN AREA)
This is the optimum amount of power to provide the perfect balance output volume and woofer longevity.

MAXIMUM RMS POWER (3200W RED AREA)
This is the maximum amount of power the woofer is designed to operate safely under. Only a moderate volume increase is gained (< 3dB) at this higher power level. Operating Beyond this power level will void your warranty.

Warranty

Thank you for purchasing a Cerwin Vega Mobile product and we hope to provide you with countless hours of listening enjoyment.

Please take a brief moment to register your new product. By registering your new product, you will receive benefits such as:

- Important product notifications that may pertain to your purchase.
- Confirmation and record of ownership in case of loss or theft.
- Knowledgeable customer service and technical assistance pertaining to your product.

Register your new product by completely filling out this Product and Warranty Registration card or register online at www.cerwinvegamobile.com.

Registration is voluntary and failure to register will not diminish your limited warranty rights.

Limited Warranty (U.S.A.)

Cerwin Vega Mobile warrants all of our amplifiers and speakers to be free of defects in materials and workmanship for a period of one (1) year.

This warranty is non-transferable and applies only to the original purchaser from an authorized Cerwin Vega Mobile dealer. If service is required and necessary under this warranty due to manufacturing defect or malfunction, then Cerwin Vega Mobile will repair and/or replace defective product with either new or remanufactured like product at no charge at our discretion.

Damage to product caused by the following will not be covered under this warranty: abuse, accident, misuse, neglect, modifications, repairing attempts, seller/installer misrepresentation.

This warranty does not cover any incidental, consequential, or cosmetic damage due to accidents or normal wear and tear, nor does it cover the cost of removing or reinstallation of the product.

Warranty is void if the product's serial number has been removed, defaced, and/or tampered with.

Warranty Procedure:

We recommend that you contact your Cerwin Vega Mobile authorized dealer where your original purchase was made to initiate all warranty claims. Our authorized dealers can guide you through the warranty procedure to ensure that your claim will be processed in a timely manner. All warranty returns must be accompanied with a proof of purchase (a copy of the original sales receipt) and be shipped freight prepaid to our facility with an RA (Return Authorization) number clearly marked on the outside of the package. Direct returns from consumers or non-authorized dealers will be refused if shipped without a valid RA number authorized by Cerwin Vega Mobile beforehand.

INTERNATIONAL

Products purchased outside of the U.S.A. are covered only by that country's distributor and not by Cerwin Vega Mobile U.S.A.

Please Ship All Warranty Claims With Pre-Authorized RA Number To:

CV&DA Holdings, Inc.

ATTN: Customer Service Department

1225 E. 7th St.

Los Angeles, CA 90021 USA

Please Contact Customer Service for Further Warranty Information:

U.S.A.

Tel: 213-261-4161 / Fax: 213-947-4767



1225 E. 7th St. • Los Angeles, CA 90021 USA
P 213-261-4161 • F 213-947-4767

WWW.CERWINVEGAMOBILE.COM

©2017 Cerwin Vega Mobile All rights reserved.
(a division of CV & DA Holdings, Inc.)

MAKING IT LOUD SINCE 1954!