

IS PSA 165 & IC PSA 165[®]

Manuel d'utilisation / User Manual / Gebrauchsanleitung / Manuale d'uso / Manual de uso /
Manual de utilização / Handleiding / Руководство по эксплуатации /

使用手册 / 사용 설명서 / 取扱説明書 / دليل المستخدم

FR

EN

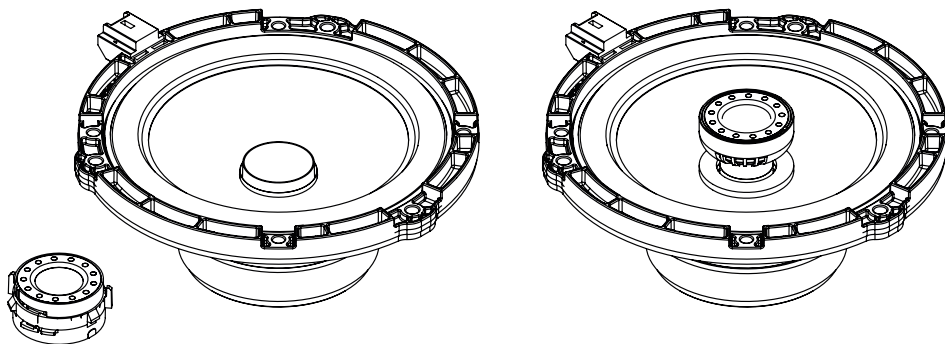

IS PSA 165 & IC PSA 165®

Manuel d'utilisation / User manual

2

**Vérifiez en ligne les compatibilités
et les consignes d'installation mises à jour.**

**Check Online Updated Compatibility list
and installation manual**

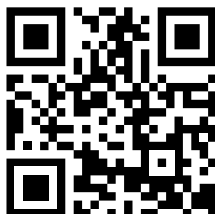

www.focal-inside.com

IS PSA 165 & IC PSA 165®

Manuel d'utilisation / User manual

	IS PSA 165	IC PSA 165
Woofers	165 mm	165 mm
Diamètre bobine	25 mm	25 mm
Membrane	Polyglass	Polyglass
Moteur	80 mm	80 mm
Impédance nominale	4 Ω	4 Ω
Tweeter	Tweeter à dome inversé en aluminium/magnésium	Tweeter à dome inversé en aluminium/magnésium
Filtre	6 dB/oct	6 dB/oct
Puissance max.	140 W	140 W
Puissance nom.	70 W	70 W
Sensibilité (2,83 V/1 m)	92,6 dB	93,2 dB
Réponse en fréquence	60 Hz - 20 kHz	60 Hz - 20 kHz
Accessoires	Livré avec accessoires de montage, vis, supports.	Livré avec accessoires de montage, vis, supports.

	IS PSA 165	IC PSA 165
Woofers	165mm	165mm
Voice coil diameter	25mm	25mm
Cone	Polyglass	Polyglass
Magnet	80mm	80mm
Nominal impedance	4Ω	4Ω
Tweeter	Aluminum/magnesium inverted dome tweeter	Aluminum/magnesium inverted dome tweeter
Crossover	6dB/oct	6dB/oct
Max. power	140W	140W
Nom. power	70W	70W
Sensitivity (2.83V/1m)	92.6dB	93.2dB
Frequency response	60Hz - 20kHz	60Hz - 20kHz
Accessories	Supplied with mounting accessories, screws, brackets.	Livré avec accessoires de montage, vis, supports.

IS PSA 165 & IC PSA 165®

Manuel d'utilisation

Français

Pour validation de la garantie Focal-JMlab,
il est maintenant possible d'enregistrer son produit en ligne : www.focal.com/garantie



FR

Vous venez d'acquérir un produit Focal et nous vous en remercions. Bienvenue dans notre univers, celui de la Haute-Fidélité. Innovation, tradition, excellence et plaisir sont nos valeurs ; notre seul objectif est de vous offrir un son pur, fidèle et riche. Afin d'exploiter toutes les performances de votre produit, nous vous conseillons de lire les instructions de ce livret puis de le conserver soigneusement pour vous y référer ultérieurement.

Conditions de garantie

La garantie pour la France sur tout matériel Focal est de 2 ans. En cas de matériel défectueux, celui-ci doit être expédié à vos frais, dans son emballage d'origine auprès du revendeur, lequel analysera le matériel et déterminera la nature de la panne. Si celui-ci est sous garantie, le matériel vous sera rendu ou remplacé. Dans le cas contraire, un devis de réparation vous sera proposé. La garantie ne couvre pas les dommages résultant d'une mauvaise utilisation ou d'un branchement incorrect (bobines mobiles brûlées par exemple...). En dehors de la France, le matériel Focal est couvert par une garantie dont les conditions sont fixées localement par le distributeur officiel Focal de chaque pays, en accord avec les lois en vigueur sur le territoire concerné.

Avertissement

L'écoute prolongée à fort niveau au-delà de 110 dB peut détériorer durablement l'audition. Des écoutes même brèves à plus de 130 dB peuvent provoquer des lésions auditives irréversibles.

Recommandations importantes

Avant tout, vérifiez l'espace disponible sur l'encastrement des haut-parleurs (se reporter aux plans sur l'emballage) puis procédez aux découpes. Dans le cas d'un montage en emplacement d'origine, vérifiez qu'il y ait un espace suffisant entre le haut-parleur et la grille de protection.

- Tenir les haut-parleurs à l'écart des copeaux métalliques et des poussières.
- Procéder à un nettoyage soigneux avant de monter les haut-parleurs.

Période de rodage

Les haut-parleurs IS PSA 165 & IC PSA 165 sont des éléments mécaniques complexes qui exigent une période d'adaptation pour fonctionner au mieux de leurs possibilités et s'adapter aux conditions de température et d'humidité de votre environnement. Cette période de rodage varie selon les conditions rencontrées et peut se prolonger sur quelques semaines. Pour accélérer cette opération, nous vous conseillons de faire fonctionner vos haut-parleurs une vingtaine d'heures à niveau moyen, sur des programmes musicaux riches en grave. Une fois les caractéristiques des haut-parleurs totalement stabilisées, vous pourrez profiter intégralement des performances de vos kits IS PSA 165 & IC PSA 165.

IS PSA 165 & IC PSA 165®

User manual

English

Please validate your Focal-JMlab warranty,
it is now possible to register your product online: www.focal.com/warranty



Thank you for purchasing a Focal product. Welcome to our High-Fidelity world. Innovation, tradition, excellence and pleasure are our values; our one and only aim is to bring you a sound that is rich, pure and true. To get the most out of your product, we recommend that you read the instructions in this booklet, then store it in a safe place to refer to in the future.

Conditions of warranty

All Focal loudspeakers are covered by warranty drawn up by the official Focal distributor in your country. Your distributor can provide all details concerning the conditions of warranty. Warranty cover extends at least to that granted by the legal warranty in force in the country where the original purchase invoice was issued.

Warning

Continuous listening at high sound level (above 110dB) can durably damage your hearing. Listening above 130dB can damage your hearing permanently.

Important recommendations

Before attempting any installation, check first how much space is available to fit the speakers into the vehicle (cf plans on the packaging), then proceed with the cutting. In the case of assembly in original location, check that there is enough space between the speaker and the protections grille.

- Ensure the speaker is clean from debris and metallic particles that may be attached (especially after drilling).
- Clean before mounting the speakers.

Running period

IS PSA 165 & IC PSA 165 drive units use the very latest components. To ensure such complex mechanical elements work in harmony with each other, they must be allowed to function correctly in this environment. Changes in temperature and humidity are regarded as very hostile. In order to get the best of your IS PSA 165 & IC PSA 165 speakers, a running-in period must be respected to ensure they are ready for this. We recommend that, once the system is ready for listening, the drive units should be run-in with medium volume setting, with music that has the full bandwidth of frequencies (sub-bass through treble). This running-in period should last for a few weeks, to gain the full potential. After which the excellent performance of your IS PSA 165 & IC PSA 165 kits can be fully appreciated.

IS PSA 165 & IC PSA 165®

Manuel d'utilisation / User manual

6

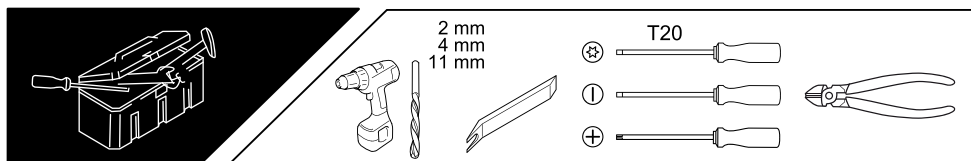
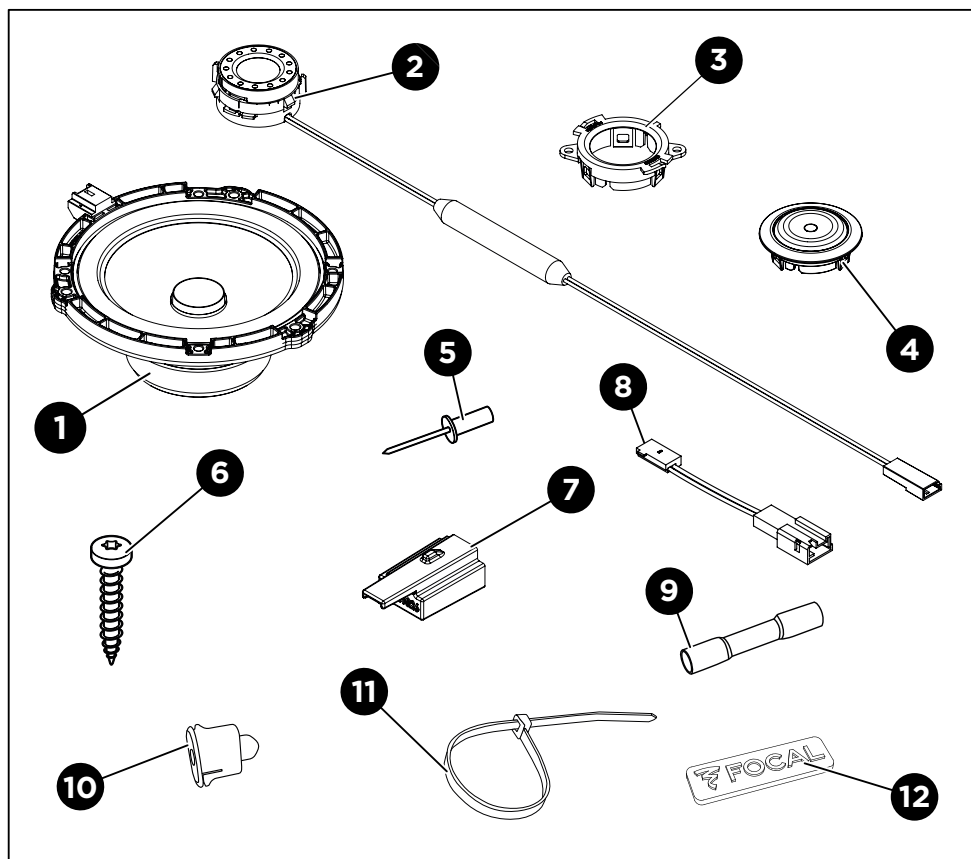
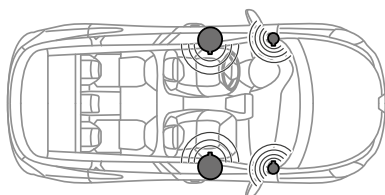

IS PSA 165 & IC PSA 165®

Manuel d'utilisation / User manual

7

Installing the front speaker drivers / Montage des woofers sur portière avant

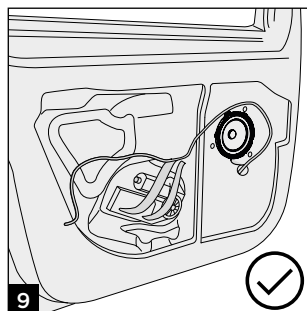
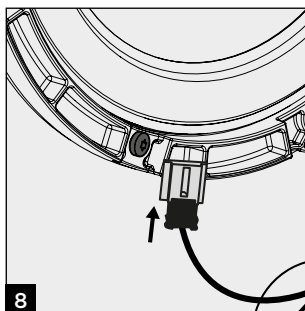
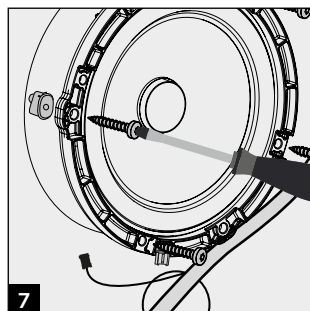
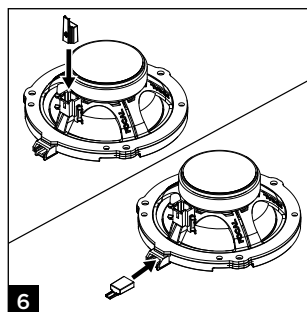
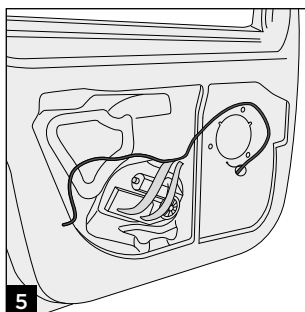
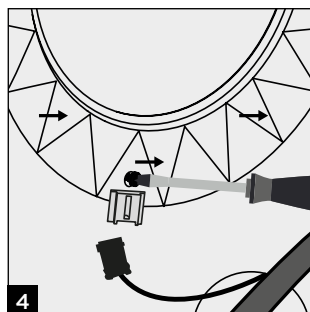
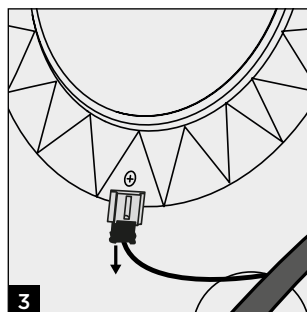
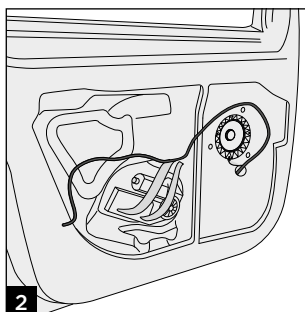
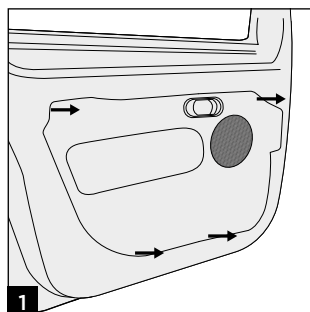
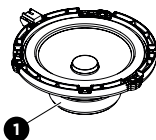
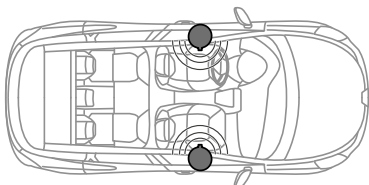

IS PSA 165 & IC PSA 165®

Manuel d'utilisation / User manual

8

Installing the tweeters ② on the front door with the original connectors. Use the supplied adapter ⑧ if necessary to connect the tweeter / Montage des tweeters ② sur portière avant avec connecteur d'origine. Si nécessaire utilisez la bretelle d'adaptation ⑧ fournie pour connecter le tweeter

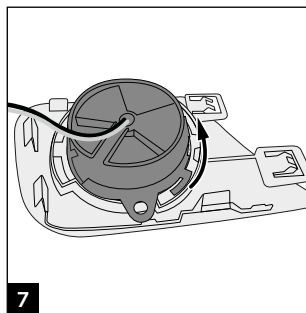
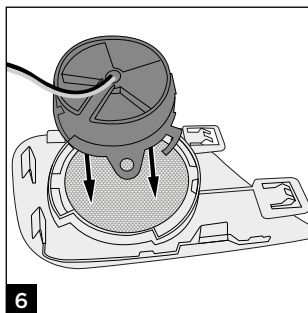
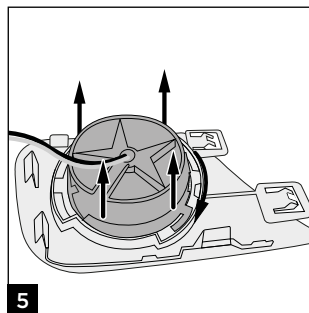
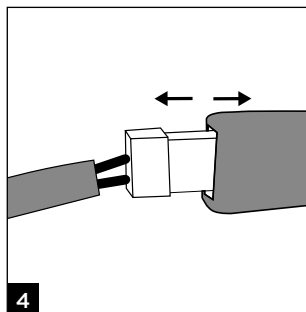
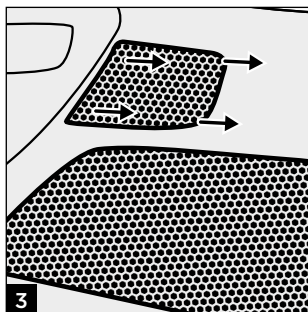
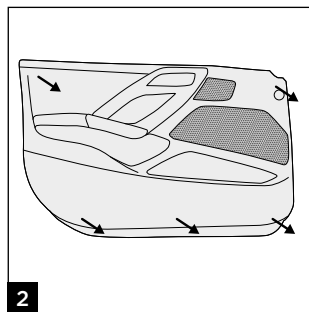
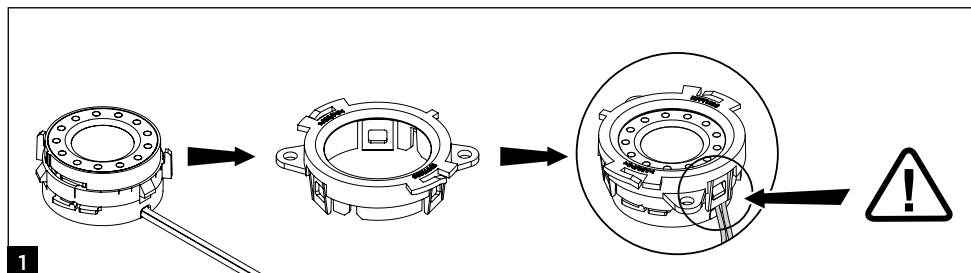
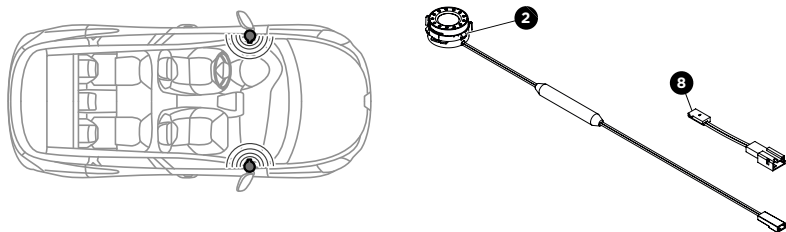

IS PSA 165 & IC PSA 165®

Manuel d'utilisation / User manual

9

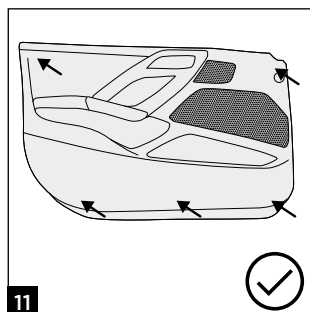
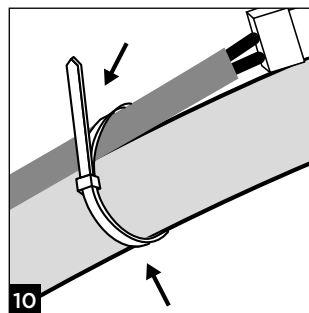
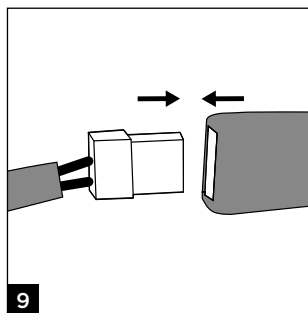
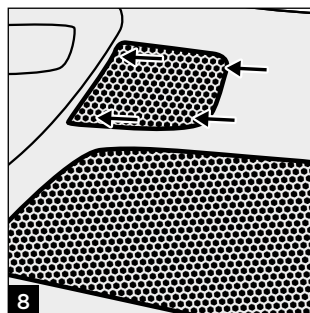

IS PSA 165 & IC PSA 165®

Manuel d'utilisation / User manual

10

Installing the tweeters ② on the front door or dashboard without the original connector /
Montage des tweeters ② sur portière avant ou tableau de bord sans connecteur d'origine

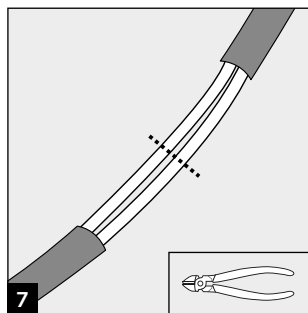
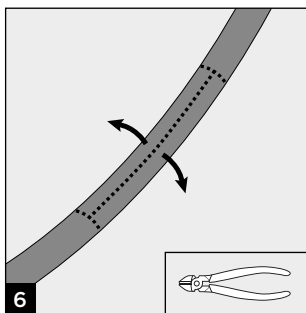
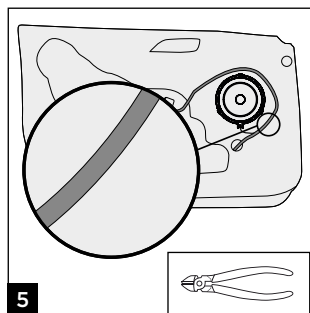
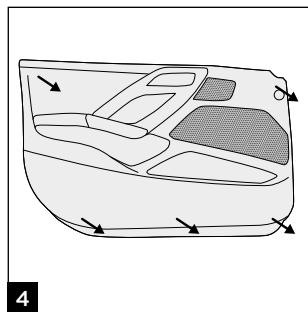
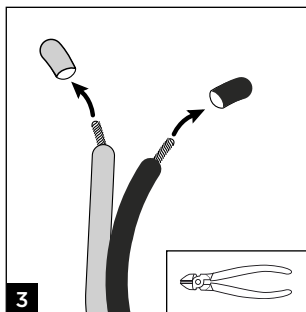
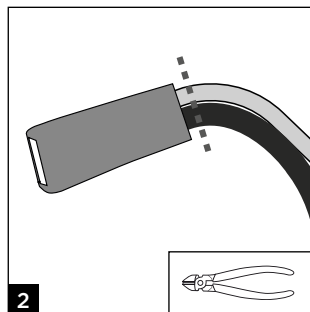
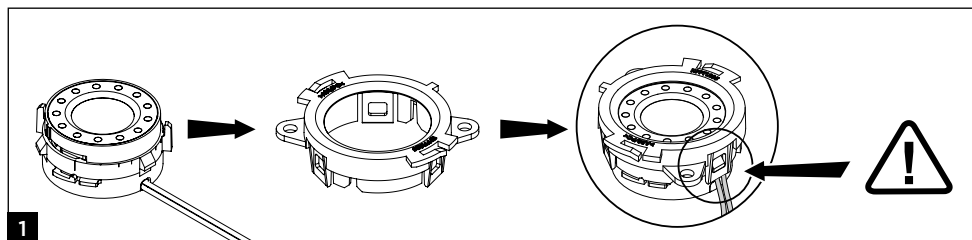
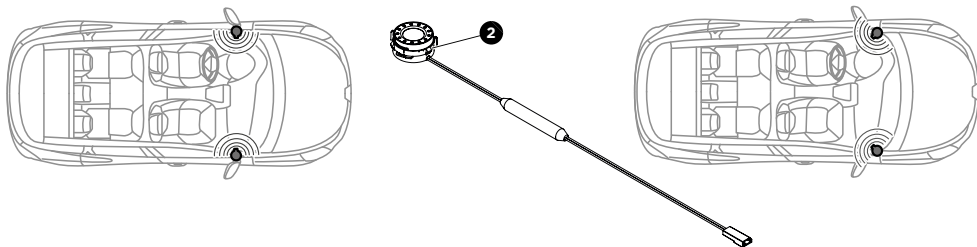

IS PSA 165 & IC PSA 165®

Manuel d'utilisation / User manual

11

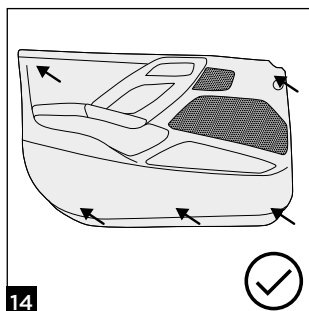
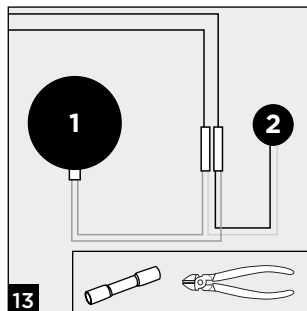
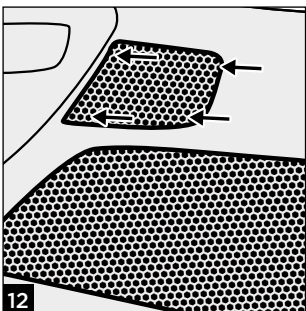
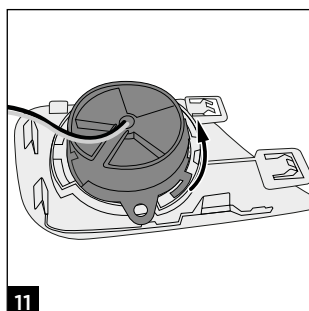
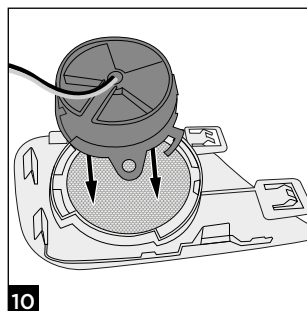
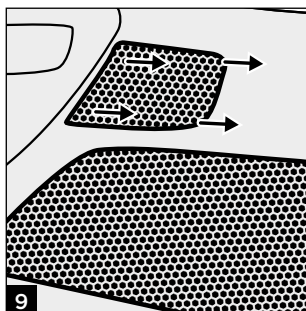
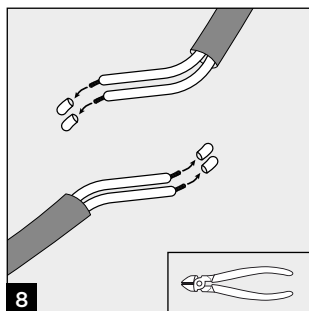

IS PSA 165 & IC PSA 165®

Manuel d'utilisation / User manual

12

Installing the tweeters ② on the dashboard with the original connectors. Use the supplied adapter ③ if necessary to connect the tweeter / Montage des tweeters ② sur tableau de bord avec connecteur d'origine. Si nécessaire utilisez la bretelle d'adaptation ③ fournie pour connecter le tweeter.

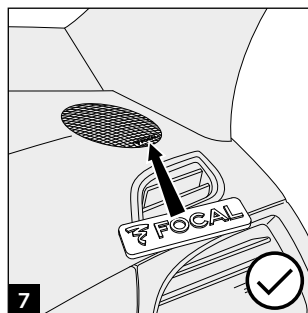
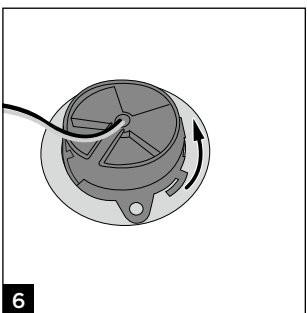
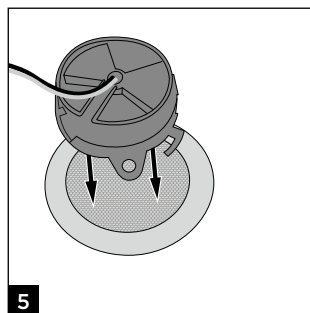
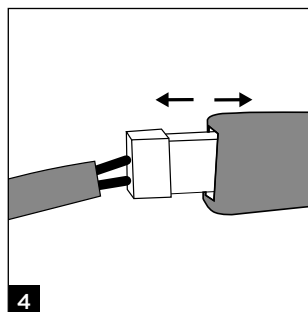
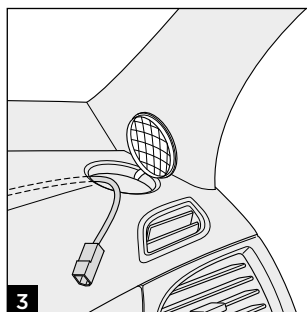
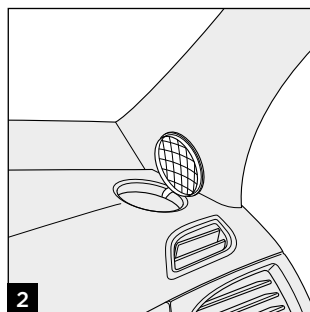
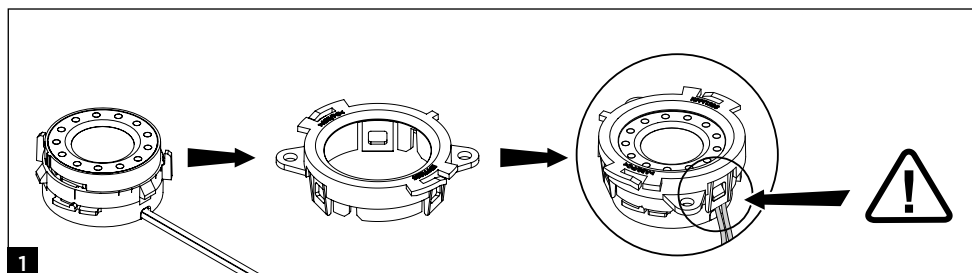
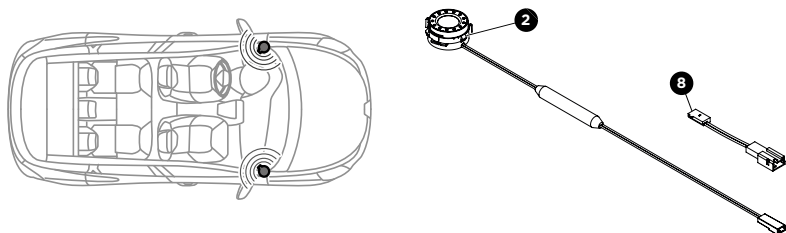

IS PSA 165 & IC PSA 165®

Manuel d'utilisation / User manual

13

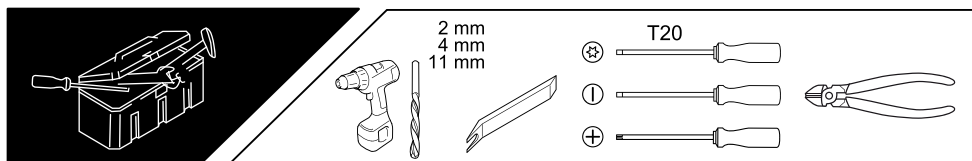
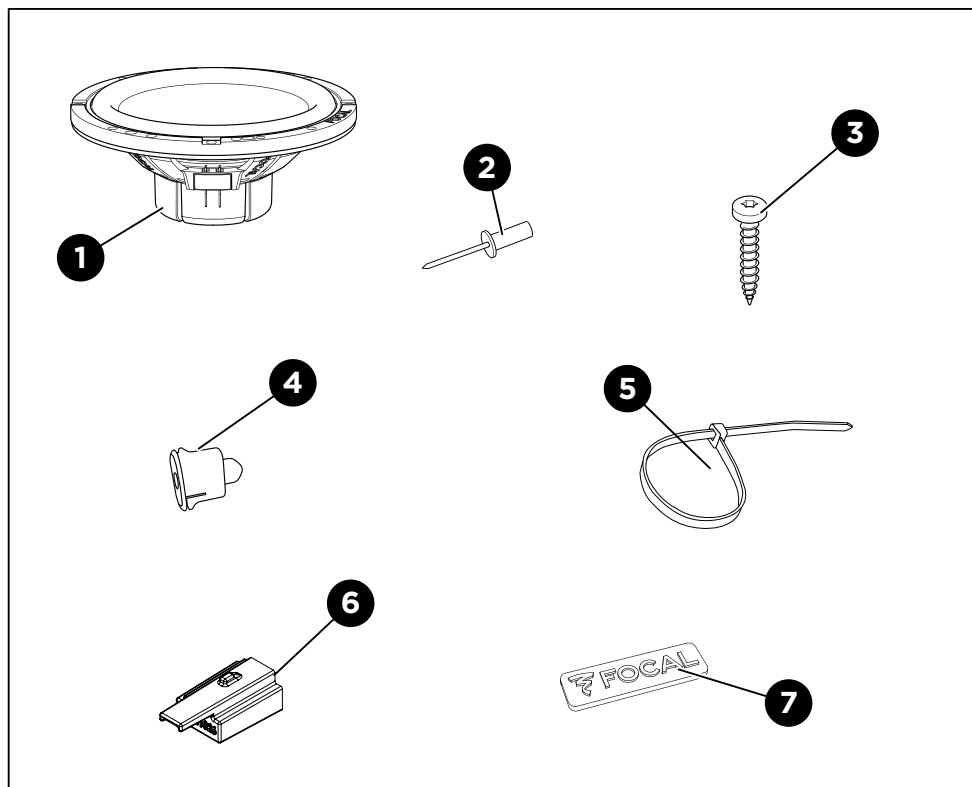
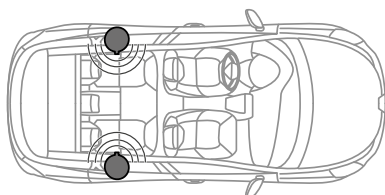

IS PSA 165 & IC PSA 165®

Manuel d'utilisation / User manual

14

Installing the rear speaker drivers / Montage des woofers sur portières arrière

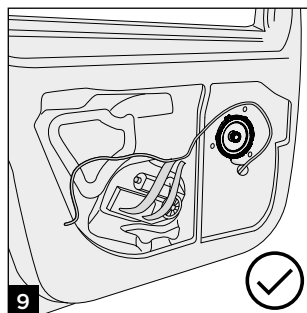
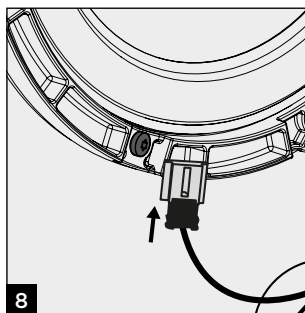
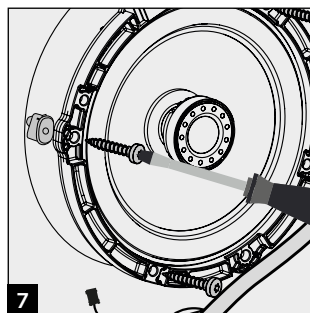
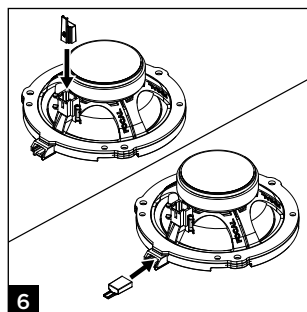
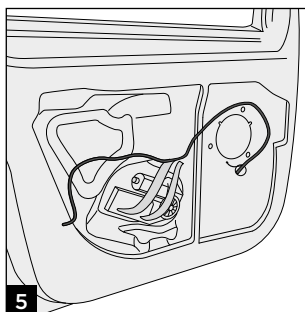
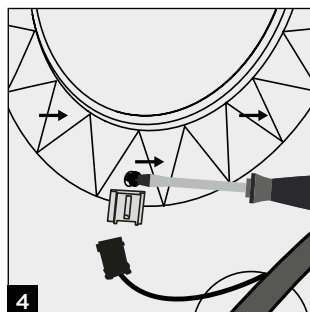
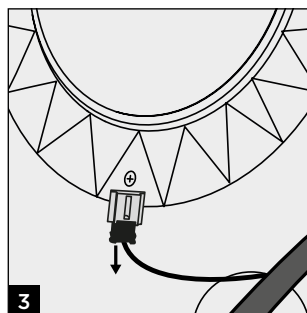
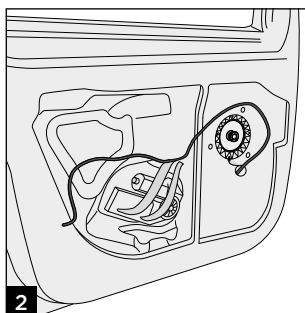
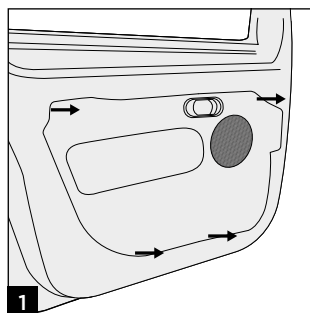
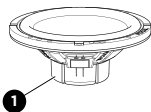
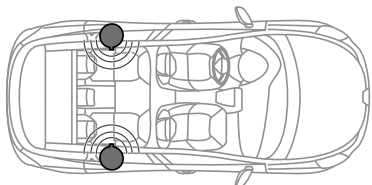

IS PSA 165 & IC PSA 165®

15



Élimination correcte de ce produit.

Ce marquage indique que ce produit ne doit pas être éliminé avec les autres déchets ménagers au sein de l'UE. Par mesure de prévention pour l'environnement et pour la santé humaine, veuillez le recycler de manière responsable, pour favoriser la réutilisation des ressources matérielles. Pour retourner votre appareil usé, veuillez utiliser les systèmes de retour et de collecte ou contactez le détaillant chez lequel le produit a été acheté. Celui-ci pourra procéder au recyclage du produit en toute sécurité.

FR



Correct elimination of this product.

This marking indicates that within the EU this product should not be disposed of with other household wastes. To prevent any risk to the environment or human health, please recycle them responsibly to encourage the reuse of material resources. To return your used device, please use the return and collection systems available, or contact the retailer where you purchased the product. They can recycle this product safely.

GB



Ordnungsgemäße Entsorgung des Produkts.

Diese Kennzeichnung weist darauf hin, dass dieses Produkt innerhalb der EU nicht mit anderen Haushaltsabfällen entsorgt werden darf.

Als Präventivmaßnahme für die Umwelt und die menschliche Gesundheit muss auf eine verantwortungsbewusste Wiederverwertung zur Förderung der Wiederverwendung von materiellen Ressourcen geachtet werden. Für die Rückgabe von Gebrauchtgeräten verwenden Sie bitte zur Verfügung stehende Rückgabe- und Recyclingsysteme oder wenden Sie sich an den Händler, bei dem Sie das Produkt erworben haben. Letzterer kann das Gerät sicher dem Wertstoffkreislauf zuführen.

DE



Eliminación correcta de este producto.

Este símbolo indica que este producto no debe eliminarse con el resto de residuos domésticos dentro de la UE. Con el objetivo de proteger el medioambiente y la salud pública, recicle de forma responsable para favorecer la reutilización de los recursos materiales. Para devolver su aparato usado, utilice los sistemas de devolución y recogida o póngase en contacto con el vendedor del producto. Este podrá proceder al reciclaje del producto de forma totalmente segura.

ES



Corretto smaltimento di questo prodotto.

Questa marcatura indica che, nell'UE, questo prodotto non deve essere smaltito insieme agli altri rifiuti domestici. A titolo preventivo per l'ambiente e la salute, deve essere riciclato in modo responsabile per favorire il riutilizzo delle risorse materiali. Per mandare indietro l'apparecchio usato, si prega di utilizzare il sistema di reso e raccolta o di contattare il rivenditore da cui è stato acquistato il prodotto, il quale potrà procedere a riciclare il prodotto in totale sicurezza.

IT



Eliminação correta deste produto.

Esta marca indica que, na UE, este produto não deve ser eliminado com outro lixo doméstico. Como medida de prevenção para o ambiente e para a saúde humana, deve ser reciclado de modo responsável, para promover a reutilização dos recursos materiais. Para devolver o seu dispositivo usado, recorra aos sistemas de devolução e recolha ou contacte o comerciante em que o produto foi adquirido. Este poderá proceder à reciclagem do produto com toda a segurança.

PT



Prawidłowe usuwanie produktu.

To oznaczenie informuje, że produktu nie należy usuwać wraz z innymi odpadami z gospodarstwa domowego na terenie UE. W celu ochrony środowiska i zdrowia człowieka, należy w sposób odpowiedzialny prowadzić recykling i wspierać ponowne wykorzystywanie materiałów. Aby zwrócić swoje urządzenie, należy skorzystać z systemu zwrotu i odbioru prowadzonego przez sprzedawcę detalicznego, u którego produkt został nabyty. Sprzedawca będzie w stanie w sposób bezpieczny przeprowadzić recykling produktu.

PL



Tuotteen asianmukainen hävittäminen.

Tämä merkintä osoittaa, että EU:ssa tätä tuotetta ei saa hävittää muiden kotitalousjätteiden mukana. Kierrätä se vastuullisesti ehkäistäksesi mahdollisia vaaroja ympäristölle tai ihmisten terveydelle ja edistääksesi aineellisten voimavarojen uudelleenkäyttöä. Palauta käytetty laite käyttämällä saatavilla olevia palautus- ja keräysjärjestelmiä tai ota yhteys jälleenmyyjään, jolta ostit tuotteen. He voivat kierrättää tämän tuotteen turvallisesti.

FIN



Правильная утилизация продукта.

Данная маркировка указывает на то, что в пределах ЕС этот продукт не может утилизироваться вместе с бытовым мусором. В целях предотвращения загрязнения окружающей среды и нанесения ущерба здоровью человека утилизируйте продукт должным образом, позволяющим произвести его повторную переработку. Для того чтобы вернуть бывшее в употреблении устройство, используйте системы возврата и сбора сырья либо обратитесь в пункт розничной торговли, в котором вы приобрели продукт, для организации повторной переработки с соблюдением всех норм безопасности.

RU



Correcte verwijdering van dit product.

Deze marking geeft aan dat dit product in de EU niet samen met ander huishoudelijk afval mag worden weggegooid. Om het milieu en de gezondheid van de mens te beschermen, dient u het product op verantwoorde wijze te recyclen om hergebruik van materiële hulpbronnen te stimuleren. U kunt uw gebruikte apparaat retourneren bij een recyclepunt of milieustation, of neem contact op met de winkel waar u het product hebt gekocht. Zo kan het product op verantwoorde wijze worden gerecycled.

NL

IS PSA 165 & IC PSA 165®

17



Korrekt avlägsnande av produkten.

Denna märkning anger att produkten inte ska kasseras med annat hushållsavfall inom EU. För att förhindra skada på miljö och människors hälsa, vänligen återvinn produkten ansvarsfullt för att främja återanvändning av materialresurserna. Använd tillgängliga återlämnings- och insamlingsystem för att återlämna din använda anordning, eller kontakta återförsäljaren som du köpte produkten av. De kan återvinna produkten säkert.

SE



A termék helyes ártalmatlanítása.

Ez a jelölés azt jelzi, hogy a terméket nem szabad az EU területén az egyéb háztartási hulladékkal együtt kidobni. A lehetséges környezet- és egészségkárosodás elkerülése érdekében kérjük, hogy a hulladékot felelősen hasznosítsa újra, ezzel segítve a nyersanyagok újrahasznosítását. A használt eszközök visszaküldéséhez használja a rendelkezésre álló visszaküldési és gyűjtőrendszereket vagy forduljon a kiskereskedőhöz, akitől a terméket vásárolta. Ők elvégzik a termék biztonságos újrahasznosítását.

HU



Pareiza, šī produkta, likvidācija.

Šis marķējums norāda, ka Eiropas Savienībā šo produktu nedrīkst izmest kopā ar citiem sadzīves atkritumiem. Lai novērstu jebkādu risku videi vai cilvēku veselībai, lūdzam nodot produktu otrreizējai pārstrādei, lai veicinātu materiālo resursu otrreizējo izmantošanu. Lai atgrieztu savu lietoto ierīci, lūdzu, izmantojiet pieejamās atpakaļņošanas un savākšanas sistēmas, vai sazinieties ar izplatītāju, no kura iegādājāties šo produktu. Tas var droši pārstrādāt šo produktu.

LV



Pravilno odlaganje tega izdelka.

Ta oznaka pomeni, da tega izdelka v EU ni dovoljeno odlagati z drugimi gospodinjstskimi odpadki. V izogibanju povzročanju morebitne škode za okolje ali človeško zdravje izdelek reciklirajte odgovorno, da omogočite ponovno uporabo materiala. Če želite rabljeno napravo vrniti, jo vrnite prek sistemov za vračanje in zbiranje, ki so na voljo, ali pa se obrnite na trgovca, pri katerem ste izdelek kupili, ki bo izdelek varno recikliral.

SI



Správná likvidace tohoto výrobku.

Toto označení znamená, že výrobek v EU nelze likvidovat spolu s jiným domácím odpadem. Aby se předešlo možným škodám na životním prostředí či na lidském zdraví, výrobky zodpovědně recyklujte, podpořte tím opětovné využívání materiálů. Pro vrácení použitého výrobku využijte dostupné vratné a sběrné systémy nebo se spojte s maloobchodním prodejcem, kde jste výrobek zakoupili. Ti pak mohou výrobek bezpečně recyklovat.

CZ

IS PSA 165 & IC PSA 165®

18



Σωστή απόρριψη αυτού του προϊόντος.

Αυτή η σήμανση υποδεικνύει ότι το προϊόν αυτό δεν πρέπει να απορρίπτεται μαζί με άλλα οικιακά απορρίμματα εντός της ΕΕ. Για να αποφευχθεί τυχόν κίνδυνος για το περιβάλλον ή την ανθρώπινη υγεία, παρακαλείσθε να το ανακυκλώσετε υπεύθυνα για να προωθήσετε την επαναχρησιμοποίηση των υλικών πόρων. Για να επιστρέψετε τη μεταχειρισμένη συσκευή σας, χρησιμοποιήστε τα διαθέσιμα συστήματα επιστροφής και συλλογής ή επικοινωνήστε με το κατάστημα από το οποίο αγοράσατε το προϊόν. Αυτοί μπορούν να ανακυκλώσουν το προϊόν με ασφάλεια.

GR



Tinkamas šio gaminio šalinimas.

Šis ženklas reiškia, kad ES šalyse šio gaminio negalima išmesti su buitinėmis atliekomis. Norėdami išvengti pavojaus aplinkai arba žmonių sveikatai, atsakingai pasirūpinkite jo perdirbimu, kad paskatintumėte pakartotinį medžiagų panaudojimą. Norėdami grąžinti panaudotą prietaisą, pasinaudokite esamomis atliekų grąžinimo ir surinkimo sistemomis arba kreipkitės į pardavėją, iš kurio įsigijote gaminį. Jie gali saugiai perdirbti šį gaminį.

LT



Správna likvidácia tohto výrobku.

Toto označenie určuje, že v rámci EÚ sa tento výrobok nesmie likvidovať spolu s komunálnym odpadom z domácností. Aby sa predišlo rizikám pre životné prostredie alebo ľudské zdravie, zabezpečte ich náležitú recykláciu, čím podporíte opätovné využívanie prírodných zdrojov. Ak chcete použité zariadenie vrátiť, využite na to dostupné systémy zberu a recyklácie odpadu alebo požiadajte o pomoc predajcu, u ktorého ste výrobok kúpili. Ten dokáže tento výrobok bezpečne recyklovať.

SK



Selle toote õige kõrvaldamine.

See märgis näitab, et ELis ei tohi seda toodet käidelda koos muude majapidamisjäätmetega. Ohu vältimiseks keskkonnale või inimeste tervisele viige need vastutustundlikult ümbertöötlusse, et soodustada materjaliresursside taaskasutamist. Oma kasutatud seadme tagastamiseks kasutage saadavalolevaid tagastus- ja kogumissüsteeme või võtke ühendust jaemüüjaga, kellelt te toote ostsite. Müüja võib selle toote ohutult ümbertöötlusse viia.

EE



Korrekt eliminering af dette produkt.

Dette mærke indikerer, at dette produkt, i overensstemmelse med EU, ikke skal bortskaffes sammen med andet husholdningsaffald. For at undgå enhver risiko for miljøet eller menneskers sundhed, skal du genanvende det på ansvarlig vis og således fremme genbrug af materielle ressourcer. Hvis du ønsker at returnere din brugte enhed, skal du bruge de returnerings- og indsamlingsssystemer, der er tilgængelige, eller kontakte forhandleren, hvor du købte produktet. De kan genbruge dette produkt på sikker vis.

DK

Pour validation de la garantie Focal-JMlab,
il est maintenant possible d'enregistrer son produit en ligne :
www.focal.com/garantie



Please validate your Focal-JMlab warranty,
it is now possible to register your product online:
www.focal.com/warranty



Registrieren Sie Ihr Produkt online, um Ihre Focal-JMlab-Garantie zu bestätigen:
www.focal.com/warranty

Per validare la garanzia Focal-JMlab adesso è possibile registrare il prodotto on-line su:
www.focal.com/warranty

Para validar la garantía Focal-JMlab, ahora también puede registrar su producto en línea:
www.focal.com/warranty

Para validar a garantia Focal-JMlab, agora é possível registrar um produto online:
www.focal.com/warranty

Voor garantie validatie Focal -JMlab, Het is nu mogelijk om het product online te registreren:
www.focal.com/warranty

Для подтверждения гарантии Focal-JMlab, теперь продукт можно зарегистрировать на сайте
www.focal.com/warranty

请于10天内寄回随附的产品质保书，使Focal-JMlab质保生效。您现在可以在线注册产品：
www.focal.com/warranty

Focal-JMlab의 개런티 유효화를 위해, 이제 웹사이트에서 제품의 온라인 저장 등록도 가능합니다 :
www.focal.com/warranty

Focal-JMlabの保証を有効にするには、現在、製品のオンライン登録が可能になりました:
www.focal.com/warranty

الرجاء تفعيل ضمان **Focal-JMlab** الخاص بك،
يمكنك الآن تسجيل منتجك عبر الإنترنت على موقع:
www.focal.com/warranty

