



Chevrolet Impala 2014-up*

*Visit MetraOnline.com for up-to-date vehicle specific applications.

KIT FEATURES

- ISO DIN radio provision with pocket
- ISO DDIN radio provision
- Painted matte black to match the factory finish

KIT COMPONENTS

- A) Radio trim panel • B) Radio filler plate • C) Radio brackets • D) Pocket • E) Lower bracket • F) (8) #8 x 3/8" Phillips screws
- G) (2) Panel clips • F) Felt tape (not shown)

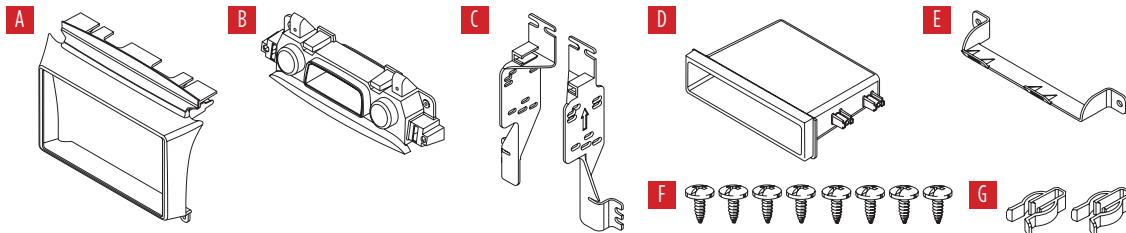

TABLE OF CONTENTS

Dash Disassembly	2-4
Kit Preparation	5
Kit Assembly	
–ISO DIN radio provision with pocket	6
–ISO DDIN radio provision.....	7

WIRING & ANTENNA CONNECTIONS

Wiring Harness: GMOS-MOST-02
 Antenna Adapter: 40-EU55 & 44-EC48
 Steering Wheel Control Interface: ASWC-1
 (sold separately)

TOOLS REQUIRED

- Panel removal tool • Phillips screwdriver
- 9/32" Socket wrench • 9/32" Wrench

CAUTION! All accessories, switches, climate controls panels, and especially air bag indicator lights must be connected before cycling the ignition. Also, do not remove the factory radio with the key in the on position, or while the vehicle is running.

DASH DISASSEMBLY

1. Open the passenger door, then unclip and remove the panel on the side of the dash. (Figure A)
2. Unclip and remove the entire upper trim panel above the glovebox, then remove (3) 9/32" screws. (Figure B)
3. Unclip and pull back the left and right sides of the front of the center console, just enough to access the screws securing the storage pocket. (Figure C)

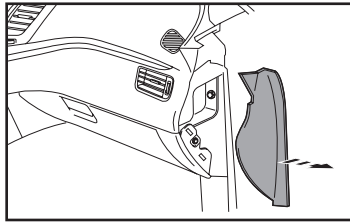

(Figure A)

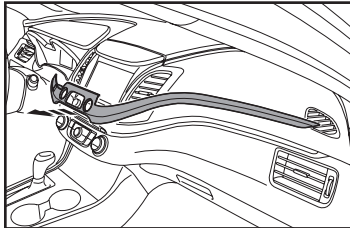

(Figure B)

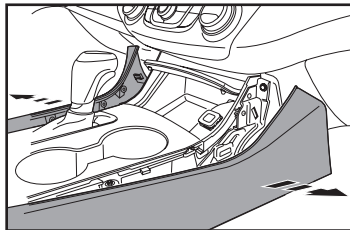

(Figure C)

4. Unclip and remove the center console top trim which houses the cup-holder. (Figure D)
5. Remove (2) 9/32" screws, and (2) Torx T-15 screws securing the storage pocket, then unclip and remove the pocket. (Figure E)
6. Remove (1) 9/32" screw now exposed, facing up, just a couple turns to allow the panel above to slide away from the screw in the following step. (Figure F)

Continue to the next page

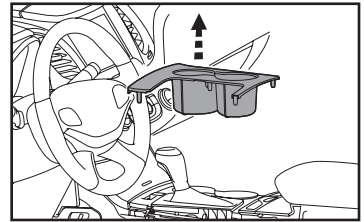

(Figure D)

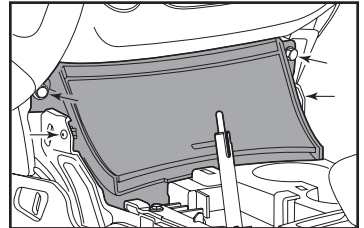

(Figure E)

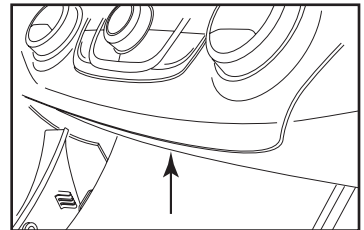

(Figure F)

DASH DISASSEMBLY (CONT.)

7. Unclip, unplug, and remove the lower dash panel. (Figure G)

Note: There are (2) clips in the middle, below the climate controls, that are extremely difficult to remove.

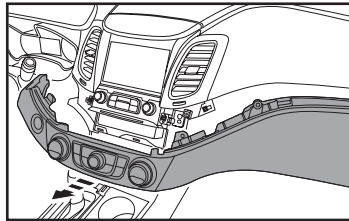

(Figure G)

8. Open the driver's door, then unclip and remove the panel on the side of the dash. (Figure H)

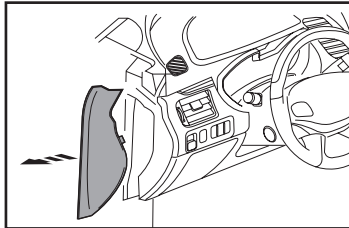

(Figure H)

9. Unclip and remove the driver's side vent panel. (Figure I)

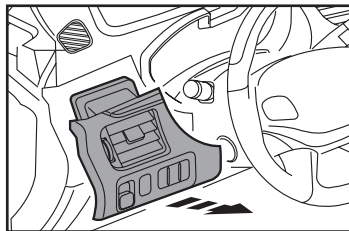

(Figure I)

10. Remove (2) 9/32" screws securing the speedometer cluster trim, then unclip and remove the trim, and also the panel on the top of the steering column (they are attached together by a leather trim piece). (Figure J)

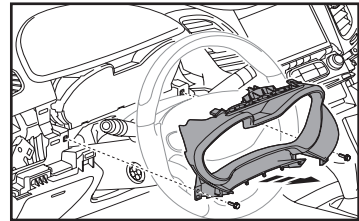

(Figure J)

11. Remove (1) 9/32" screw securing the left middle a/c vent, then unclip and remove. (Figure K)

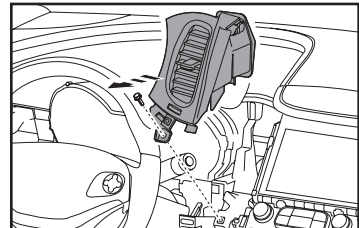

(Figure K)

12. Remove (1) 9/32" screw securing the right middle a/c vent, then unclip and remove. (Figure L)

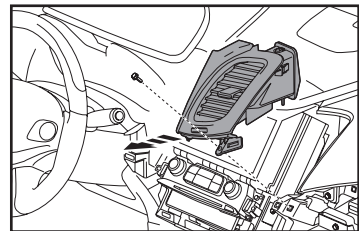

(Figure L)

Continue to the next page

DASH DISASSEMBLY (CONT.)

- Remove (4) 9/32" screws securing the lower brackets from the radio. (Figures M,N)
- Unclip and remove the trim panel on the top of the motorized radio display. (Figure O)

Note: The panel is held on by (2) strong clips.

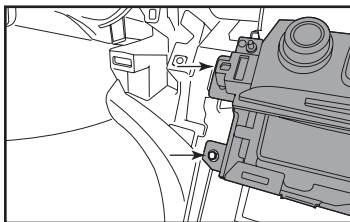

(Figure M)

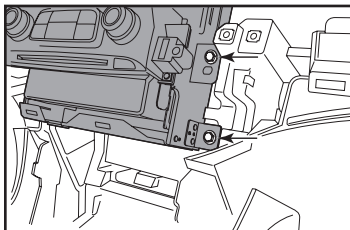

(Figure N)

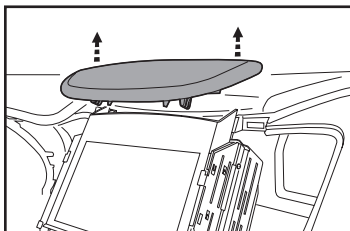

(Figure O)

- Unclip and remove the plastic trim now exposed, then remove (2) 9/32" screws. (Figure P)
- Lift slightly up and back to remove the radio, then unplug the radio and USB cable. (Figure Q)

Note: Be careful not to scratch the dash with the lower radio brackets.

- If the vehicle is equipped with a CD player, remove (2) 9/32" screws securing the CD player, then unplug and remove. (Figure R)

Continue to Kit Preparation

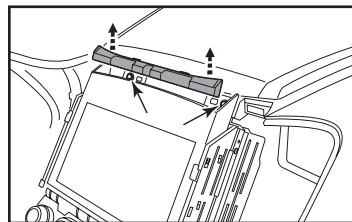

(Figure P)

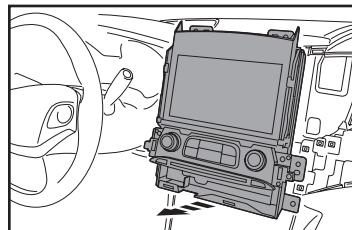

(Figure Q)

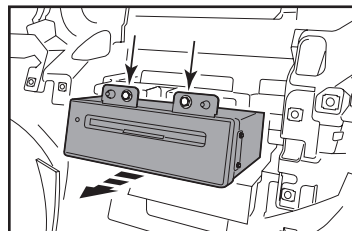

(Figure R)

KIT PREPARATION

1. Attach (2) *panel clips* and *felt tape* provided onto the *radio trim panel*. (Figure A)
 2. **For models with a CD player:** Leave the shaded area intact.
- For models without a CD player:** Cut the scored portion from the bottom of the *radio filler plate*. (Figure B)

Continue to Kit Assembly

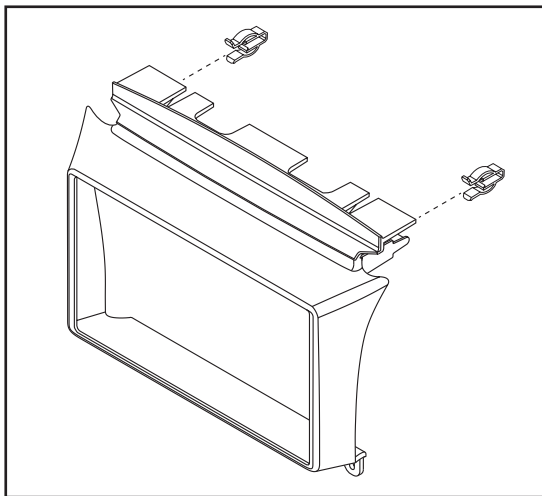

(Figure A)

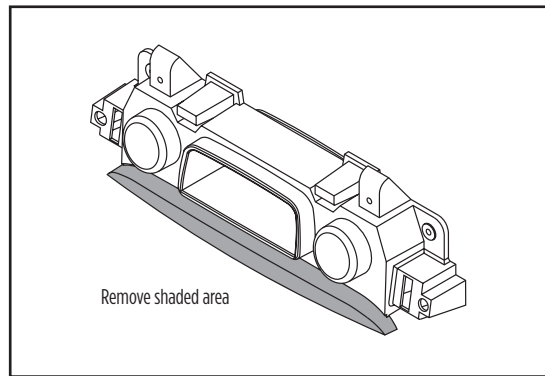

(Figure B)

KIT ASSEMBLY

ISO DIN radio provision with pocket

1. Attach the *pocket* to the *radio brackets* using the (4) #8 x 3/8" Phillips screws provided. (Figure A)
2. Remove the metal DIN sleeve and trim ring from the aftermarket radio.
3. Slide the radio into the bracket/pocket assembly, then secure it using the screws supplied with the radio. (Figure B)
4. Locate the factory wiring harness and antenna connector in the dash and complete all necessary connections to the radio. Metra recommends using the proper mating adapter from Metra and/or Axxess.

Note: The radio connections are located at the radio brain in the passenger kick panel.

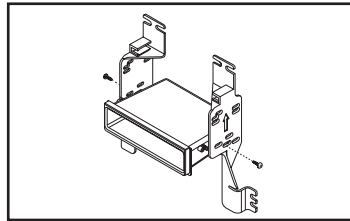

(Figure A)

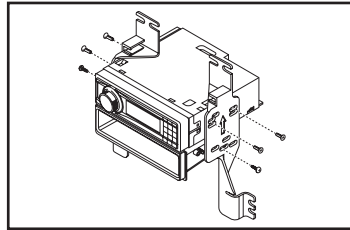

(Figure B)

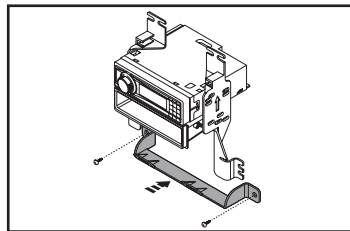

(Figure C)

5. Reconnect the climate controls, then test the radio and climate controls for proper operation.
6. Secure the completed radio assembly to the dash using the factory screws. (Figure D)
7. Secure the *lower bracket* to the dash using the factory screws. (Figure C)
8. Secure the *radio filler plate* to the slits in the radio brackets using (2) #8 x 3/8" Phillips screws provided. (Figure D)
9. Reassemble the middle a/c vents in reverse order of disassembly.
10. Clip the *radio trim panel* to the dash, then secure to the *radio knockout* using (2) #8 x 3/8" Phillips screws provided. (Figure E)
11. Reassemble the dash in reverse order of disassembly to complete the installation.

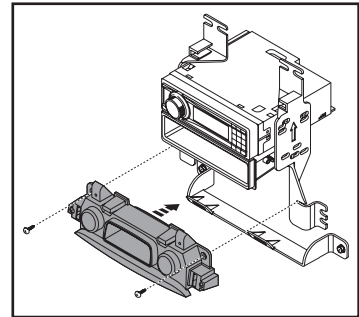

(Figure D)

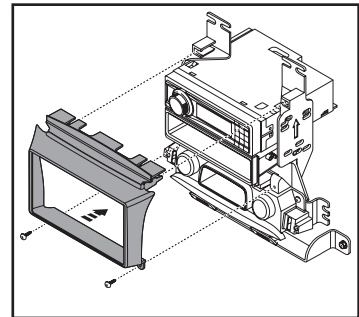

(Figure E)

KIT ASSEMBLY

ISO DDIN radio provision

1. Secure the radio to the *radio brackets* using the screws supplied with the radio. (Figure A)
2. Locate the factory wiring harness and antenna connector in the dash and complete all necessary connections to the radio. Metra recommends using the proper mating adapter from Metra and/or Axxess.

Note: The radio connections are located at the radio brain in the passenger kick panel.

3. Reconnect the climate controls, then test the radio and climate controls for proper operation.
4. Secure the completed radio assembly to the dash using the factory screws.

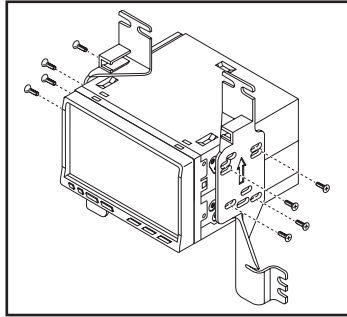

(Figure A)

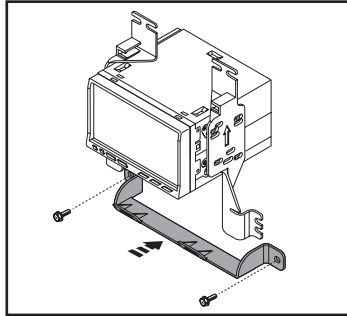

(Figure B)

5. Secure the *lower bracket* to the dash using the factory screws. (Figure B)
6. Secure the *radio filler plate* to the slits in the radio brackets using (2) #8 x 3/8" Phillips screws provided. (Figure C)
7. Reassemble the middle a/c vents in reverse order of disassembly.
8. Clip the *radio trim panel* to the dash, then secure to the *radio knockout* using (2) #8 x 3/8" Phillips screws provided. (Figure D)
9. Reassemble the dash in reverse order of disassembly to complete the installation.

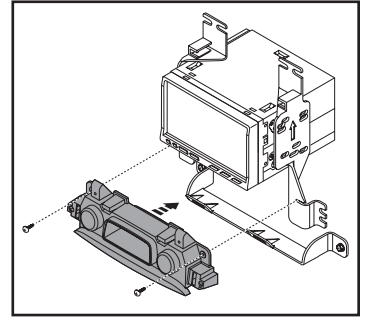

(Figure C)

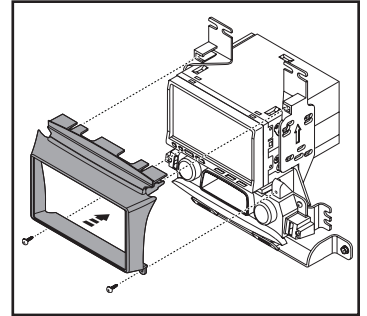

(Figure D)



99-3024B
INSTALLATION INSTRUCTIONS



IMPORTANT

If you are having difficulties with the installation of this product, please call our Tech Support line at 1-800-253-TECH. Before doing so, look over the instructions a second time, and make sure the installation was performed exactly as the instructions are stated. Please have the vehicle apart and ready to perform troubleshooting steps before calling.



KNOWLEDGE IS POWER

Enhance your installation and fabrication skills by enrolling in the most recognized and respected mobile electronics school in our industry. Log onto www.installerinstitute.com or call 800-354-6782 for more information and take steps toward a better tomorrow.



**Metra recommends MECP
certified technicians**