



## Installation instructions for part INST-FD-CR

# Ford/Chrysler 1974-2003 INST-FD-CR

### INSTALLATION INSTRUCTIONS

---

#### Section 1:

- 99-5700
- AW-509FD
- CF-509FD

#### Section 2:

- 99-6700

### TOOLS REQUIRED

---

Refer to each section title page.

### APPLICATION OVERVIEW

---

<b>99-5700/AW-509FD/ CF-509FD</b>	<b>99-6700</b>
Ford/Jeep/Lincoln/Mercury	Chrysler/Dodge/Eagle/ Ford/Jeep/Lincoln/ Mercury/Plymouth

INST-FD-CR is a collection of installation instruction booklets. Use the Application Overview when selecting which installation instruction selection to use. Each section is setup as a chapter with its own table of contents.

### Table of Contents

<b>Section 1</b> .....	2
– Dash Disassembly .....	3-11
– Kit Assembly .....	12-13
<b>Section 2</b> .....	14
– Dash Disassembly .....	15-28
– Kit Assembly .....	28
– Final Kit Assembly .....	29-30

---

**CAUTION!** All accessories, switches, climate controls panels, and especially air bag indicator lights must be connected before cycling the ignition. Also, do not remove the factory radio with the key in the on position, or while the vehicle is running.

## Section 1

Ford/Jeep  
1975-1996

### 99-5700, AW-509FD/ CF-509FD

#### KIT FEATURES

- DIN radio provision
- ISO DIN radio provision (*select vehicles*)

#### KIT COMPONENTS

- A) Radio housing #1 • B) Radio housing #2
- C) Brackets Set #1 (*Econoline*) • D) Bracket #2 (*Escort/Lynx*) • E) Spacer Set #1
- F) (4) #8 X 3/4" Phillips Pan-head screws
- G) (2) #6 Self tapping screws

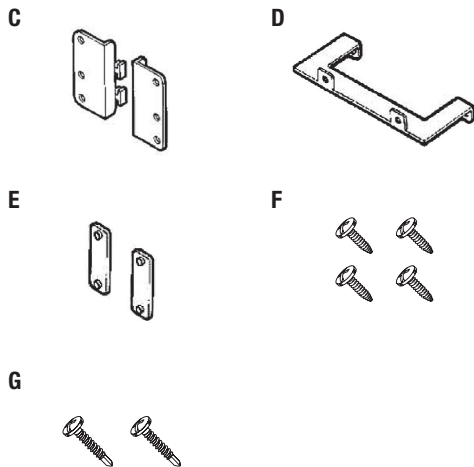
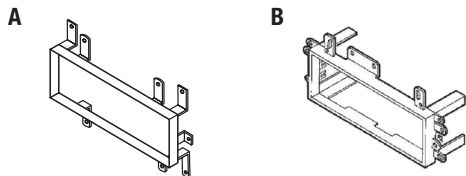

#### TOOLS REQUIRED

- Phillips screwdriver • Cutting tool
- 86-5618 Removal keys

## Applications

### Ford

Aerostar.....	1985-1991
Bronco (full).....	1987-1991
Bronco.....	1980-1986
Bronco II.....	1985-1988
Crown Victoria.....	1979-1990
Econoline.....	1975-1991
Esoort.....	1985-1990
F-Series Pickup.....	1987-1991
F-Series Pickup.....	1980-1986
Festiva.....	1988-1993
LTD.....	1979-1990
Ranger (mini).....	1985-1988
Taurus.....	1986-1989
Tempo.....	1985-1988
Thunderbird.....	1985-1988

### Jeep

Cherokee.....	1984-1995
Cherokee.....	1996
Comanche.....	1986-1992
Grand Wagoneer.....	1987-1992

Wagoner .....	1984-1996
Wrangler .....	1986-1996
<b>Lincoln</b>	
Continental .....	1985-1987
Mark VII .....	1984-1989
Town Car .....	1984-1989

### Mercury

Cougar .....	1985-1988
Grand Marquis .....	1979-1990
Lynx .....	1985-1990
Marquis .....	1979-1990
Sable .....	1986-1989
Topaz .....	1985-1988
Tracer (hatch) .....	1989-1990

## Table of Contents

<b>Dash Disassembly</b> .....	3-11
<b>Kit Assembly</b>	
– DIN radio provision .....	12-13
– ISO DIN radio provision .....	12-13

## Ford Aerostar 1985-1991

1. Remove (2) Phillips screws from the base of the dash trim bezel. (Figure A)
2. Pry down on the (2) tabs located at the top of the dash trim bezel and remove the bezel.
3. Remove (4) screws securing the factory radio and disconnect the wiring.
4. Cut and remove all mounting tabs on radio housing #2 EXCEPT tabs "D" and "F". (Figure B)
5. Locate Spacer Set#1 (the spacers must be placed behind the mounting tabs during installation).

*Continue to kit assembly*

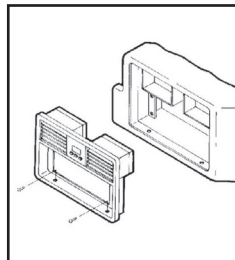

(Figure A)

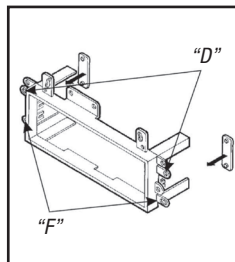

(Figure B)

*The mounting tabs can be identified by the stamped letter on the back of each tab.*

## Ford Bronco/Pickup 1980-1986

1. Remove (2) screws from the top edge of the dash trim bezel. (Figure A)
2. Pullout on the top of the bezel, unhook the base and remove the bezel. If a factory radio is NOT present, scribe the (4) mounting holes and radio opening onto the bezel.
3. Drill the holes, cut the opening and place (4) U-clips over the mounting positions.
4. Cut and remove all mounting tabs on radio housing #1 EXCEPT tabs "B". (Figure B)

*Continue to kit assembly*

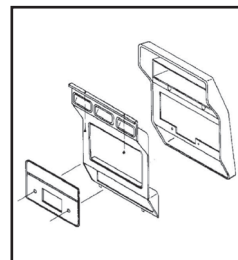

(Figure A)

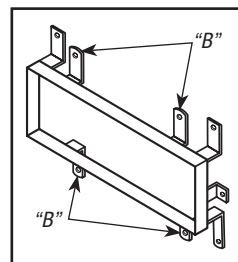

(Figure B)

*The mounting tabs can be identified by the stamped letter on the back of each tab.*

## Ford Bronco (full size) F-Series Pickup 1987-1991

1. Carefully pull and remove the dash trim bezel. (Figure A)
2. Remove (4) screws securing the factory radio and disconnect the wiring.
3. Cut and remove all mounting tabs on radio housing #2 EXCEPT tabs "D" and "F". (Figure B)
4. Locate Spacer Set#1 (the spacers must be placed behind the mounting tabs during installation).

*Continue to kit assembly*

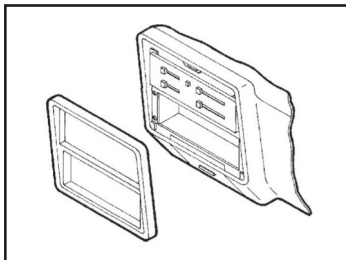

(Figure A)

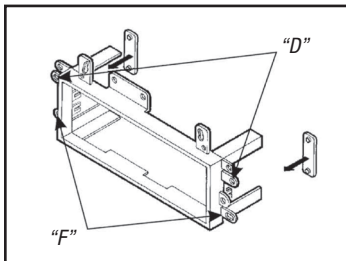

(Figure B)

*The mounting tabs can be identified by the stamped letter on the back of each tab.*

## Ford Bronco II/Ranger 1985-1988

1. Remove (4) Phillips screws from the top edge of the dash trim bezel. (Figure A)
2. Remove the light switch knob, cigarette lighter and ashtray.
3. Unsnap the molding located below the dash trim bezel and remove (4) screws exposed.
4. Remove (4) screws securing the factory radio and disconnect the wiring.
5. Cut and remove all mounting tabs on radio housing #2 EXCEPT tabs "D" and "F". (Figure B)
6. Locate Spacer Set#1 (the spacers must be placed behind the mounting tabs during installation).

*Continue to kit assembly*

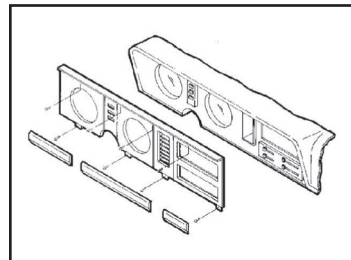

(Figure A)

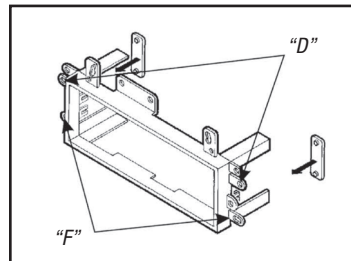

(Figure B)

## Ford Crown Victoria/LTD, Mercury Grand Marquis/Marquis 1979-1990

1. Open the ashtray and remove (2) Phillips screws securing the dash trim bezel. (Figure A)
2. Remove (4) screws securing the factory radio and disconnect the wiring.
3. Cut and remove all mounting tabs on radio housing #2 EXCEPT tabs "D" and "F". (Figure B)
4. Locate Spacer Set #1 (the spacers must be placed behind the mounting tabs during installation).

*Continue to kit assembly*

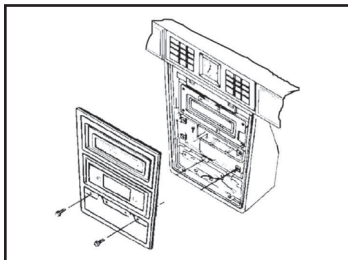

(Figure A)

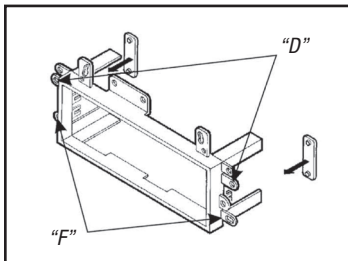

(Figure B)

*The mounting tabs can be identified by the stamped letter on the back of each tab.*

## Ford Econoline 1975-1991

1. Remove (3) screws from the lower edge of the dash trim bezel. (Figure A)
2. Remove (2) screws above the radio opening. Unsnap the right corner of the dash trim bezel, disconnect the cigarette lighter wiring and remove the bezel. (Figure A)
3. Remove the screws securing the factory radio and disconnect the wiring.
4. Cut and remove all mounting tabs on radio housing #2. Slide Bracket Set#1 into the slots on the sides of the housing. (Figure B)

*Continue to kit assembly*

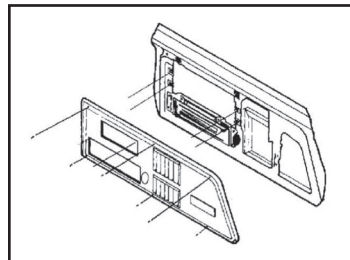

(Figure A)

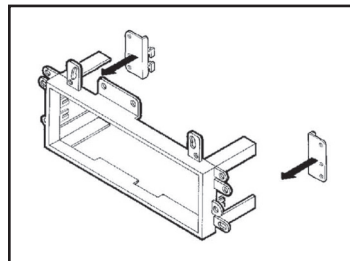

(Figure B)

*The mounting tabs can be identified by the stamped letter on the back of each tab.*

## Ford Escort/Mercury Lynx 1985-1990

1. Remove (4) screws from the top edge of the dash trim bezel. (Figure A)
2. Remove (2) screws from the bottom edge of the dash trim bezel. (Figure A)
3. Remove the climate control knobs and remove the bezel.
4. Remove (4) hex-head screws securing the factory radio and disconnect the wiring.
5. Cut and remove all mounting tabs on radio housing #2 EXCEPT tabs "B". (Figure B)
5. Mount Bracket #2 to the bottom of the housing with (2) #8 x 3/4" Phillips Screws supplied.

*Continue to kit assembly*

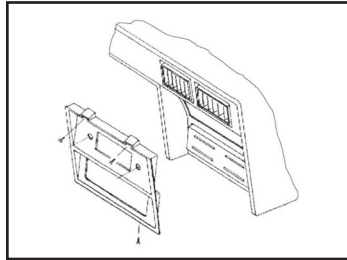

(Figure A)

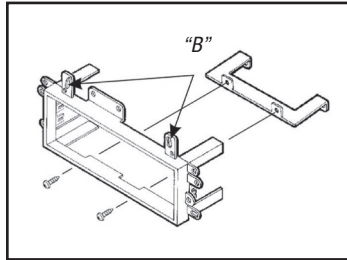

(Figure B)

*The mounting tabs can be identified by the stamped letter on the back of each tab.*

## Ford Festiva 1988-1993

1. Remove (4) Phillips screws from the bottom of the dash trim bezel. (Figure A)
2. Remove the bezel. Remove (2) screws securing the factory radio and disconnect the wiring. (Figure A)
3. Cut and remove all mounting tabs on radio housing #1 EXCEPT tabs "C". (Figure B)

*Continue to kit assembly*

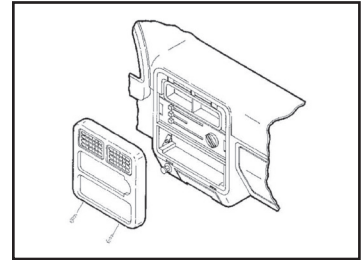

(Figure A)

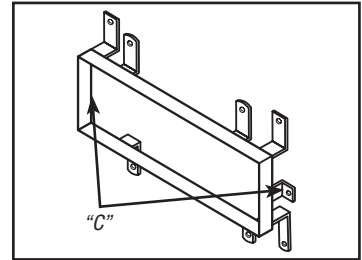

(Figure B)

*The mounting tabs can be identified by the stamped letter on the back of each tab.*

## Ford Taurus/Mercury Sable 1986-1989

1. Remove (1) 7mm hex-head screw from the bottom of the radio trim bezel. Gently unclip the bezel and disconnect the antenna switch power lead. (Figure A)
2. Remove (4) screws securing the factory radio and disconnect the wiring.
3. Cut and remove all mounting tabs on radio housing #2 EXCEPT tabs "A" and "G". (Figure B)

*Continue to kit assembly*

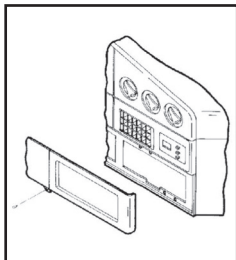

(Figure A)

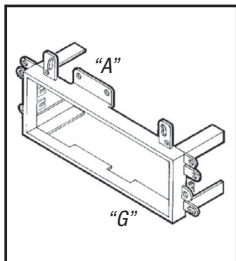

(Figure B)

*The mounting tabs can be identified by the stamped letter on the back of each tab.*

## Ford Tempo/Mercury Topaz 1985-1988

1. Remove the ashtray by disengaging the release tab at the rear of the ashtray bracket.
2. Remove (2) screws from the lower edge of the dash trim bezel. Unclip the top edge of the bezel and remove. (Figure A)
3. Remove (4) screws securing the factory radio and disconnect the wiring.
4. Cut and remove all mounting tabs on radio housing #1 EXCEPT tabs "A". (Figure B)

*Continue to kit assembly*

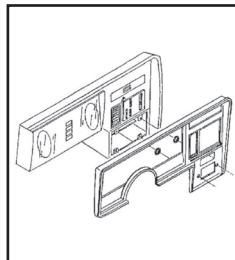

(Figure A)

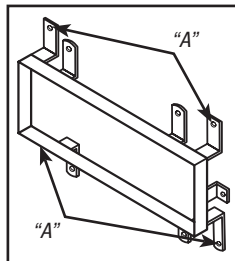

(Figure B)

*The mounting tabs can be identified by the stamped letter on the back of each tab.*

## Ford Thunderbird/Mercury Cougar 1985-1988

1. Remove (2) screws from the top of the dash trim bezel. (Figure A)
2. Open the ashtray and remove (2) screws from the ashtray cavity. (Figure A)
3. Remove (4) screws securing the factory radio and cut and remove all mounting tabs on radio housing #2 EXCEPT tabs "D" and "F". (Figure B)
4. Locate Spacer Set#1 (the spacers must be placed behind the mounting tabs during installation).

*Continue to kit assembly*

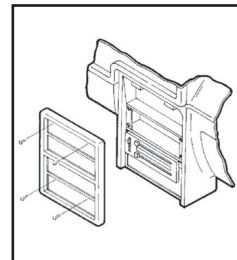

(Figure A)

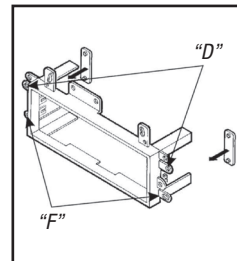

(Figure B)

*The mounting tabs can be identified by the stamped letter on the back of each tab.*

## Jeep Cherokee 1984-1995/ Comanche 1986-1992/ Wagoneer 1984-1996

1. Unsnap the steering column trim panel and remove. (Figure A)
2. Remove (4) screws from the dash trim bezel and remove the bezel. (Figure A)
3. Remove (2) screws securing the factory radio and disconnect the wiring.
4. Cut and remove all mounting tabs on radio housing #2 EXCEPT tabs "E". (Figure B)

*Continue to kit assembly*

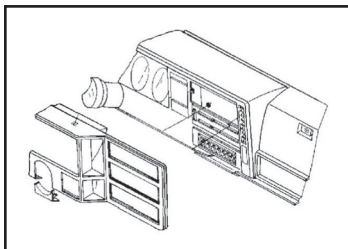

(Figure A)

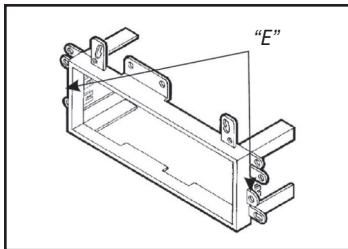

(Figure B)

*The mounting tabs can be identified by the stamped letter on the back of each tab.*

## Jeep Cherokee 1996

1. Remove (3) torx-head screws from the steering column trim panels.
2. Unscrew the tilt steering lever and unsnap the trim panels. Remove (4) screws from the dash trim bezel and remove the bezel. (Figure A)
3. Remove (2) screws securing the factory radio and disconnect the wiring.
4. Cut and remove all mounting tabs on radio housing #2 EXCEPT tabs "E". (Figure B)

*Continue to kit assembly*

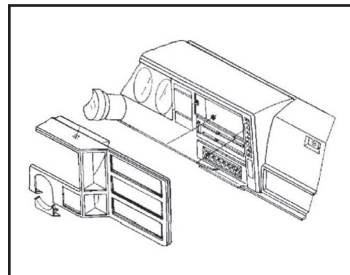

(Figure A)

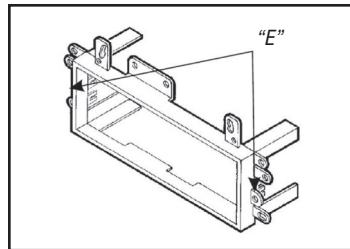

(Figure B)

*The mounting tabs can be identified by the stamped letter on the back of each tab.*



## Jeep Grand Wagoneer 1987-1992

1. Gently unclip the dash trim bezel. (Figure A)
2. Remove (2) screws securing the factory radio and disconnect the wiring.
3. Cut and remove all mounting tabs on radio housing #2 EXCEPT tabs "E". (Figure B)

*Continue to kit assembly*

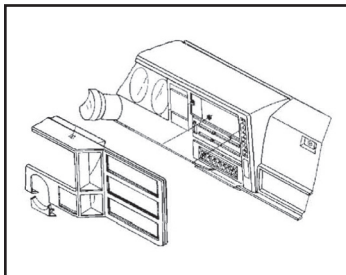

(Figure A)

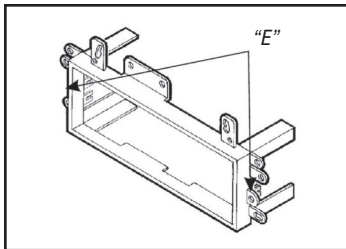

(Figure B)

*The mounting tabs can be identified by the stamped letter on the back of each tab.*

## Jeep Wrangler 1986-1996

1. Remove (6) Phillips screws from the face of the dash trim bezel. (Figure A)
2. Remove the bezel. Remove (2) screws securing the factory radio and disconnect the wiring.
3. Cut and remove all mounting tabs on radio housing #2 EXCEPT tabs "B". (Figure B)

*Continue to kit assembly*

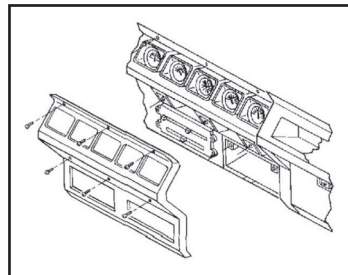

(Figure A)

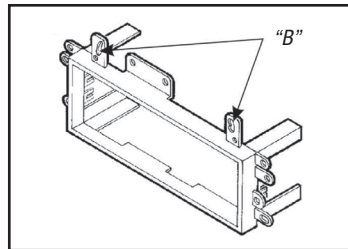

(Figure B)

*The mounting tabs can be identified by the stamped letter on the back of each tab.*

## Lincoln Continental 1985-1987

1. Remove (2) #8 Phillips screws below the radio opening. (Figure A)
2. Open the ashtray and remove (2) #8 Phillips screws exposed (it is NOT necessary to remove the center screw). (Figure A)
3. Unclip and remove the dash trim bezel.
4. Remove (4) hex-head screws securing the factory radio and disconnect the wiring.
5. Cut and remove all mounting tabs on radio housing #2 EXCEPT tabs "D" and "F". (Figure B)
6. Locate Spacer Set#1 (the spacers must be placed behind the mounting tabs during installation).

*Continue to kit assembly*

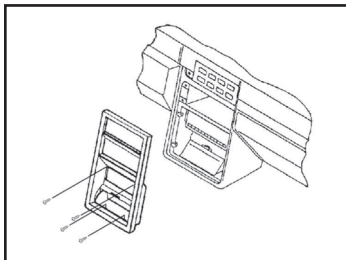

(Figure A)

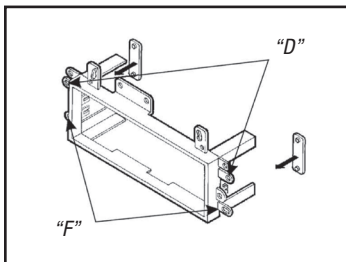

(Figure B)

*The mounting tabs can be identified by the stamped letter on the back of each tab.*

## Lincoln Mark VII 1984-1989

1. Gently pry out on the dash trim bezel and remove. (Figure A)
2. Remove (4) 5mm hex-head sheet metal screws securing the factory radio and disconnect the wiring.
3. Cut and remove all mounting tabs on radio housing #2 EXCEPT tabs "D" and "F". (Figure B)
4. Locate Spacer Set#1 (the Spacers must be placed behind the mounting tabs during installation).

*Continue to kit assembly*

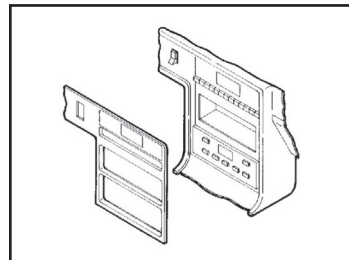

(Figure A)

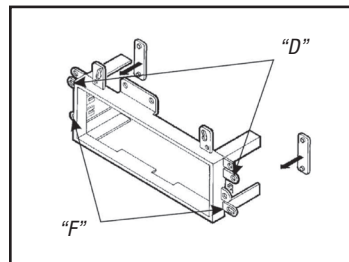

(Figure B)

*The mounting tabs can be identified by the stamped letter on the back of each tab.*

## Lincoln Town Car 1984-1989

1. Remove (3) #8 Phillips screws from the bottom of the radio trim bezel. (Figure A)
2. Unsnap the plastic strip located above the bezel and remove (3) Phillips screws exposed. (Figure A)
3. Gently pull the instrument cluster trim bezel away from the dash and remove the radio trim bezel.
4. Remove (3) hex-head screws securing the factory radio and disconnect the wiring.
5. Cut and remove all mounting tabs on radio housing #2 EXCEPT tabs "D" and "F". (Figure B)
6. Locate Spacer Set#1 (the spacers must be placed behind the mounting tabs during installation).

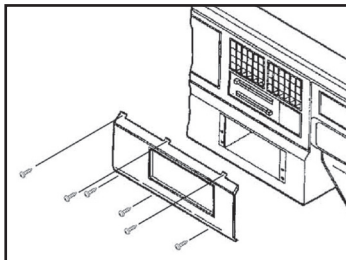

(Figure A)

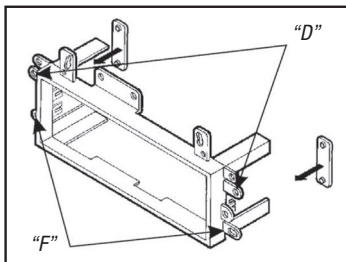

(Figure B)

*Continue to kit assembly*

## Mercury Tracer (hatchback) 1989-1990

1. Remove (3) Phillips screws from the top of the dash trim bezel. (Figure A)
2. Remove the ashtray and (2) Phillips screws from the bottom of the bezel. (Figure A)
3. Remove (4) Phillips screws securing the factory radio and disconnect the wiring.
4. Cut and remove all the mounting brackets from radio housing #1. (Figure B)

*Continue to kit assembly*

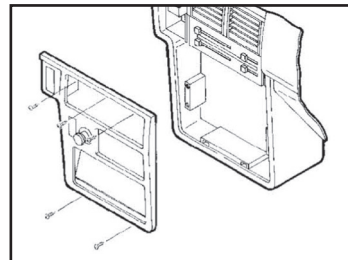

(Figure A)

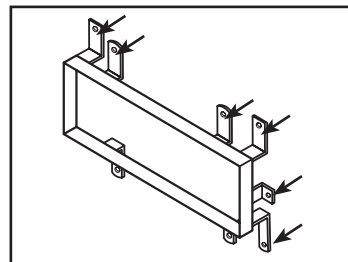

(Figure B)



## Kit Assembly INST-FD-CR

**Aerostar 1985-1991, Bronco 1987-1991, Bronco II 1985-1988, Crown Victoria 1979-1990, Econoline 1975-1991, Escort 1985-1990, F-Series Pickup 1987-1991, LTD 1979-1984, Ranger 1985-1988, Taurus 1986-1989, Thunderbird 1985-1988, Continental 1985-1987, Mark VII 1984-1989, Town car 1984-1989, Cougar 1985-88, Grand Marquis 1979-1990, Lynx 1985-1990, Marquis 1979-1990, Sable 1986-1989, Tracer (hatchback) 1988-1990, All Jeeps**

1. Slide the DIN cage into radio housing #2 and secure by bending the metal locking tabs down. (Figure A)
2. Slide the aftermarket radio into the cage until secure. (Figure A)

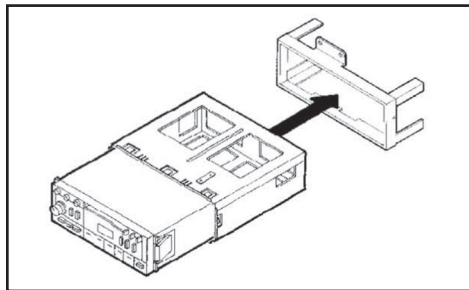

(Figure A)

**Bronco 1980-1986, F-Series Pickup 1980-1986, Festiva 1988-1993, Tempo 1985-1988, Topaz 1985-1988**

1. Slide the DIN cage into the housing and secure by bending the metal locking tabs down. (Figure A)
2. Slide the aftermarket radio into the cage until secure. (Figure A)

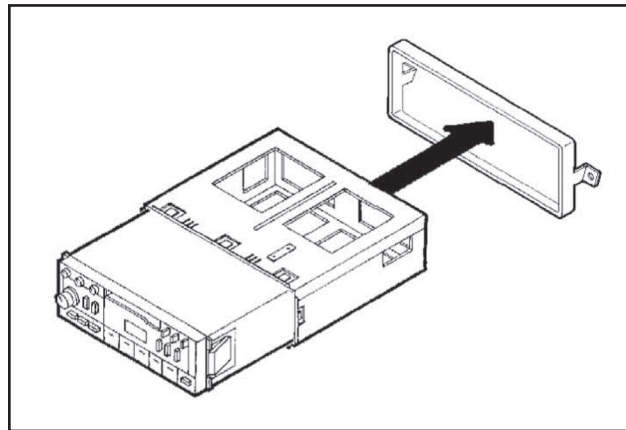

(Figure A)



## Section 2

Ford/Jeep  
1974-2003

**99-6700**

### KIT FEATURES

- DIN radio provision

### KIT COMPONENTS

- A) Radio housing • B) Support spacers (*Avenger/Sebring*)

**A**

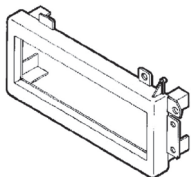

**B**

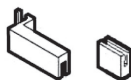

### TOOLS REQUIRED

- Phillips screwdriver • Cutting tool • Socket wrench

## Applications

### Chrysler

Cirrus .....	1995-2000
Concorde .....	1993-1997
Cordoba .....	1975-1978
Cordoba .....	1979-1983
E-Class .....	1983-1984
Fifth Avenue .....	1990-1994
Imperial .....	1982-1983
Imperial .....	1990-1994
Laser .....	1984-1986
LeBaron .....	1976-1981
LeBaron .....	1982-1985
LeBaron .....	1986-1994
LeBaron GTS .....	1985-1994
LHS .....	1993-1997
Newport .....	1980-1981
New Yorker .....	1980-1981
New Yorker .....	1983-1987
New Yorker .....	1988-1996
Sebring .....	1995-2000
Sebring (conv) .....	1996-2000
Town & Country ..	1990-1995
Town & Country ..	1996-2000

### Dodge

Aries .....	1981-1989
Aspen .....	1976-1980
Avenger .....	1995-2000
Caravan .....	1984-1990

Caravan .....	1991-1995
Caravan .....	1996-2000
Charger .....	1974-1978
Charger .....	1983-1987
Dakota .....	1987-1996
Dakota .....	1997-2000
Daytona .....	1984-1989
Daytona .....	1990-1993
Diplomat .....	1976-1989
Durango .....	1997-2000
Dynasty .....	1988-1993
Intrepid .....	1993-1997
Lancer .....	1985-1989
Magnum XE .....	1978-1979
Mirada .....	1980-1983
Neon .....	1994-1999
Omni .....	1978-1982
Pickup .....	1974-1980
Pickup .....	1981-1993
Ram .....	1994-2001
Ramcharger .....	1974-1980
Ramcharger .....	1981-1993
Rampage .....	1978-1982
Shadow .....	1987-1994
Spirit .....	1989-1995
SI Regis .....	1979-1981
Stratus .....	1995-2000
Van .....	1978-2003
024 .....	1978-1982

400 .....	1982-1983
600 .....	1983-1987

### Eagle

Vision .....	1993-1997
--------------	-----------

### Ford

Aerostar .....	1985-1991
Bronco II .....	1985-1988
Crown Victoria ..	1979-1990
LTD .....	1979-1990
Ranger (mini) .....	1985-1988
Thunderbird .....	1985-1988

### Jeep

Cherokee .....	1997-2001
Grand Cherokee ..	1993-1995
Grand Cherokee ..	1996-1998
Wrangler .....	1997-2002

### Lincoln

Continental .....	1985-1987
Mark VII .....	1984-1989

### Mercury

Cougar .....	1985-1988
--------------	-----------

Grand Marquis ..	1979-1990
Marquis .....	1979-1990

### Plymouth

Acclaim .....	1989-1995
Breeze .....	1996-2000
Caravelle .....	1985-1987
Fury .....	1975-1978
Gran Fury .....	1975-1985
Horizon .....	1978-1982
Neon .....	1994-1999
Reliant .....	1981-1989
Scamp .....	1983-1984
Sundance .....	1987-1994
TC3 .....	1978-1982
Trailduster .....	1974-1980
Trailduster .....	1981
Wrangler .....	1983-1987
Van .....	1978-2003
Volare .....	1976-1980
Voyager .....	1984-1990
Voyager .....	1991-1995
Voyager .....	1996-2000

## Table of Contents

Dash Disassembly .....	15-28
------------------------	-------

### Kit Assembly

– DIN radio provision .....	28
– Final kit assembly .....	29-30

## Chrysler Cirrus/Dodge Stratus 1995-2000, Plymouth Breeze 1996-2000

- Using a flat-blade screwdriver, pry out on the edges of the radio trim bezel. Unclip the bezel and remove. (Figure A)
- Remove (2) 3/8" hex-head screws securing the factory radio and disconnect the wiring.
- Cut and remove all mounting tabs on the radio housing EXCEPT the shaded tabs. (Figure B)

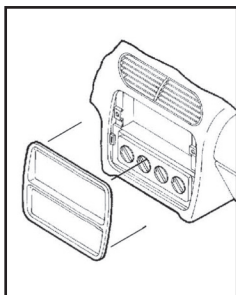

(Figure A)

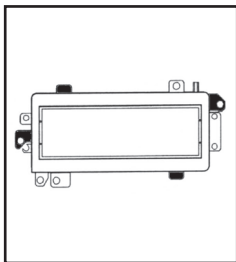

(Figure B)

*Continue to kit assembly*

## Chrysler Concorde/LHS/Dodge Intrepid/Eagle Vision 1993-1997

- Unclip the radio trim bezel and remove. (Figure A)
- Remove (2) 3/8" hex-head screws securing the factory radio and disconnect the wiring.
- Cut and remove all mounting tabs on the radio housing EXCEPT the shaded tabs. (Figure B)

*Continue to kit assembly*

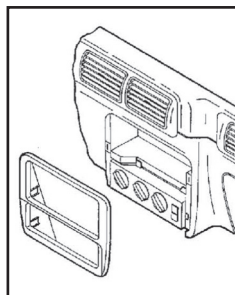

(Figure A)

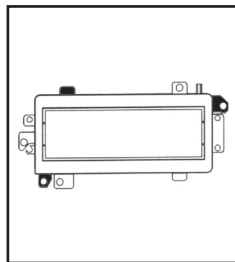

(Figure B)

## Chrysler Cordoba/Plymouth Fury 1975-1978, Dodge Charger 1974-1978/Magnum XE 1978-1979

- Remove (4) Phillips screws from the bottom edge of the radio trim bezel.
- Remove (2) Phillips screws above the radio opening. (Figure A)
- Unscrew the retainer ring securing the remote mirror control and remove the bezel. (Figure A)
- Remove (2) 3/8" hex-head screws securing the factory radio and disconnect the wiring.
- Cut and remove all mounting tabs on the radio housing EXCEPT the shaded tabs. (Figure B)

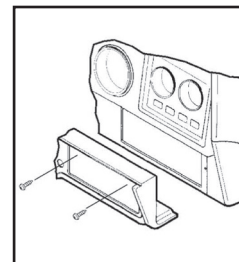

(Figure A)

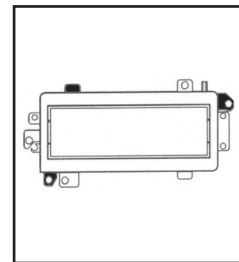

*Continue to kit assembly* (Figure B)

## Chrysler Cordoba 1979-1985/Imperial 1982-1983, Newport/New Yorker 1980-1981, Dodge Mirada 1980-1983/ St. Regis 1979-1981

1. Remove (2) Phillips screws from the bottom edge of the radio trim bezel. (Figure A)
2. Remove (2) Phillips screws above the radio opening.
3. Unscrew the retainer ring securing the remote mirror control and remove the bezel.
4. Remove (2) 3/8" hex-head screws securing the factory radio and disconnect the wiring.
5. Cut and remove all mounting tabs on the radio housing EXCEPT the shaded tabs. (Figure B)

*Continue to kit assembly*

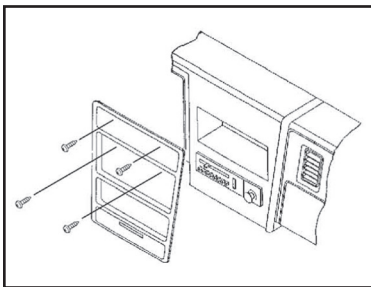

(Figure A)

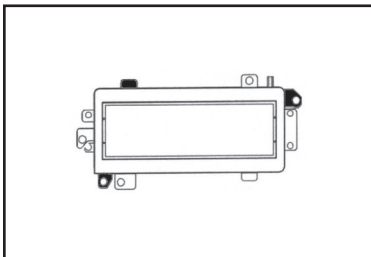

(Figure B)

## Chrysler E-Class 1983-1984/LeBaron 1982-1985/New Yorker 1983-1987, Dodge Aries 1981-1989/400 1982-1983/600 1983-1987, Plymouth Caravelle 1985-1987/ Reliant 1981-1989

1. Remove (3) Phillips screws from the top edge of the dash trim bezel.
2. Remove (3) Phillips screws from the bottom edge of the dash trim bezel.
3. Unclip the bezel and disconnect the wiring. (Figure A)
4. Remove (2) 3/8" hex-head bolts securing the factory radio and disconnect the wiring.
5. Cut and remove all mounting tabs on the radio housing EXCEPT the shaded tabs. (Figure B)

*Continue to kit assembly*

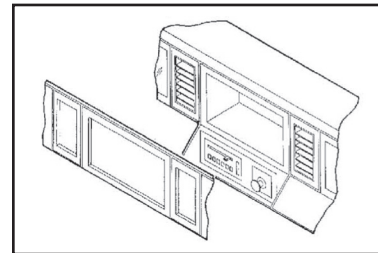

(Figure A)

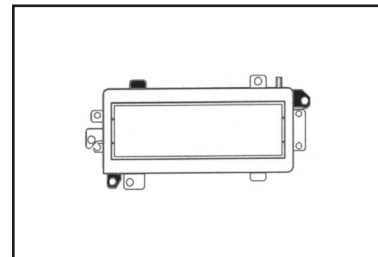

(Figure B)



## Chrysler Fifth Avenue/ Imperial 1990-1994, New Yorker 1988-1996, Dodge Dynasty 1988-1993

1. Remove (2) Phillips screws above the radio opening. (Figure A)
2. Remove (2) Phillips screws above the climate controls. (Figure A)
3. Unclip the dash trim bezel and remove.
4. Remove (2) 3/8" hex-head screws securing the factory radio and disconnect the wiring. (Figure A)
5. Cut and remove all mounting tabs on the radio housing EXCEPT the shaded tabs. (Figure B)

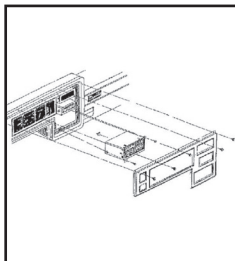

(Figure A)

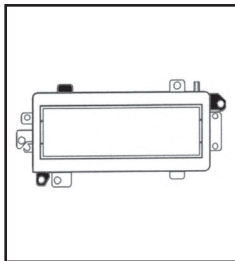

(Figure B)

*Continue to kit assembly*

## Chrysler Laser 1984-1986 Dodge Daytona 1984-1989

1. Remove (2) Phillips screws from the base of the dash trim bezel.
2. Pullout on the lower edge of the bezel and remove. (Figure A)
3. Remove (2) 3/8" hex-head screws securing the factory radio and disconnect the wiring.
4. Cut and remove all mounting tabs on the radio housing EXCEPT the shaded tabs. (Figure B)

*Continue to kit assembly*

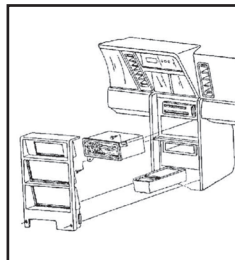

(Figure A)

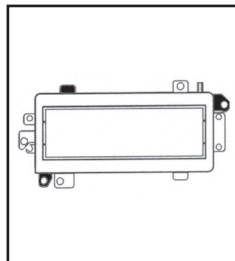

(Figure B)

## Chrysler LeBaron 1986-1994

1. Remove (1) Phillips screw from the lower corner of the dash trim bezel.
2. Unclip the bezel and remove.
3. Remove (2) Phillips screws from the right console panel and remove the panel. (Figure A)
4. Remove (2) hex-head screws securing the factory radio and disconnect the wiring.
5. Cut and remove all mounting tabs on the radio housing EXCEPT the shaded tabs. (Figure B)

*Continue to kit assembly*

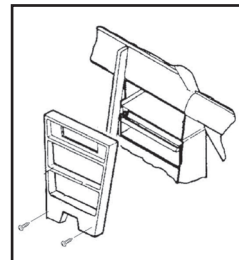

(Figure A)

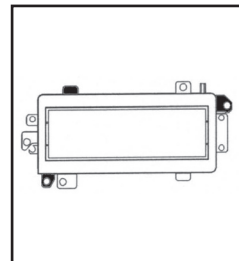

(Figure B)

### Chrysler LeBaron GT5 1985-1994, Dodge Lancer 1985-1989

1. Remove (5) torx-head screws from the top of the dash trim bezel.
2. Remove (2) torx-head screws below the radio opening.
3. Remove (1) torx-head screw from the upper-left corner of the radio opening.
4. Remove (4) torx-head screws from the lower-left area of the dash trim bezel. (Figure A)
5. Unclip the bezel and remove. Remove (2) 3/8" hex-head bolts securing the factory radio and disconnect the wiring.
6. Cut and remove all mounting tabs on the radio housing EXCEPT the shaded tabs. (Figure B)

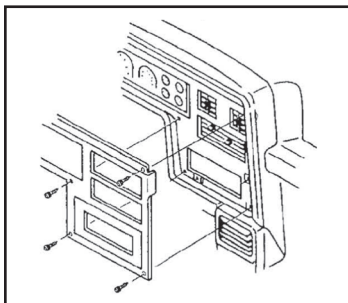

(Figure A)

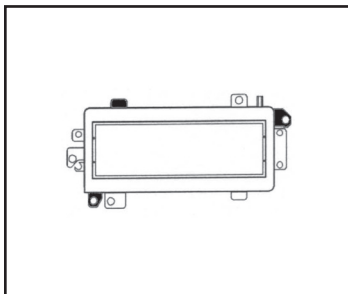

(Figure B)

*Continue to kit assembly*

### Chrysler LeBaron 1976-1981, Dodge Diplomat 1976-1989/Aspen 1976-1980, Plymouth Gran Fury 1975-1985/Volare 1976-1980

1. Remove (4) Phillips screws from the top of the dash trim bezel and then remove (4) from the bottom of the dash trim bezel. (Figure A)
2. Remove (2) 3/8" hex-head screws securing the factory radio and disconnect the wiring.
3. Cut and remove all mounting tabs on the radio housing EXCEPT the shaded tabs. (Figure B)

*Continue to kit assembly*

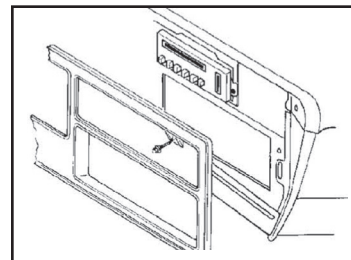

(Figure A)

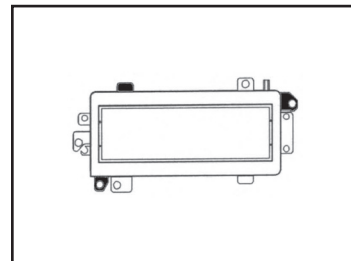

(Figure B)

### Chrysler Sebring (convertible) 1996-2000

1. Unclip the radio trim bezel and remove. (Figure A)
2. Remove (2) 3/8" hex-head screws securing the factory radio and disconnect the wiring.
3. Cut and remove all mounting tabs on the radio housing EXCEPT the shaded tabs. (Figure B)

Continue to kit assembly

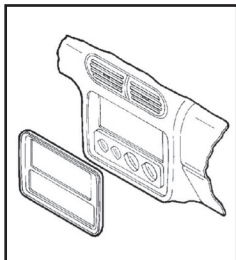

(Figure A)

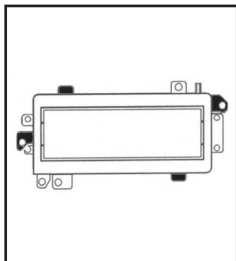

(Figure B)

### Dodge Sebring/Avenger 1995-2000

1. Unclip the radio trim bezel and remove. (Figure A)
2. Remove (2) #10 Phillips screws securing the factory radio and disconnect the wiring.
3. Cut and remove all mounting tabs on the radio housing EXCEPT the shaded tabs. (Figure B)

Continue to kit assembly

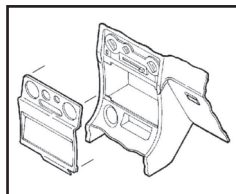

(Figure A)

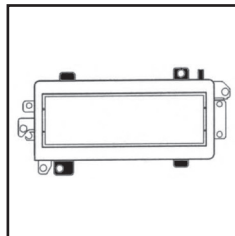

(Figure B)

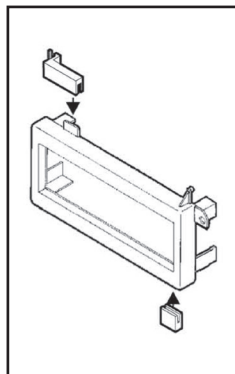

(Figure C)

### Dodge Caravan/Plymouth Voyager 1991-1995

1. Remove the cigarette lighter.
2. Using a panel removal tool, pry out on the dash trim bezel and remove. (Figure A)
3. Remove (2) 3/8" bolts securing the factory radio and disconnect the wiring.
4. Cut and remove all mounting tabs on the radio housing EXCEPT the shaded tabs. (Figure B)

Continue to kit assembly

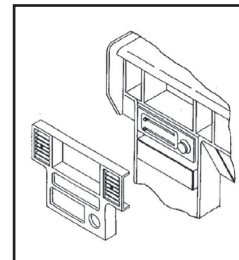

(Figure A)

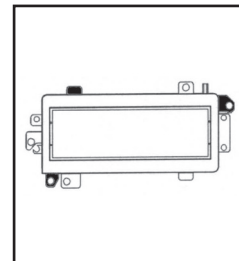

(Figure B)

## **Chrysler Town & Country 1990-1995, Dodge Caravan 1984-1990, Plymouth Voyager 1984-1990**

1. Reach behind the ashtray and release the rear tab on the ashtray housing.
2. Remove (2) screws from the bottom edge of the dash trim bezel. Remove (3) screws from the top edge of the dash trim bezel. (Figure A)
3. Unsnap the left edge of the bezel and remove.
4. Remove (2) 3/8" hex-head screws securing the factory radio and disconnect the wiring.
5. Cut and remove all mounting tabs on the radio housing EXCEPT the shaded tabs. (Figure B)

*Continue to kit assembly*

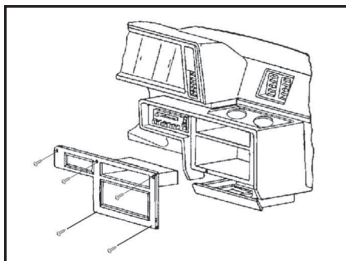

(Figure A)

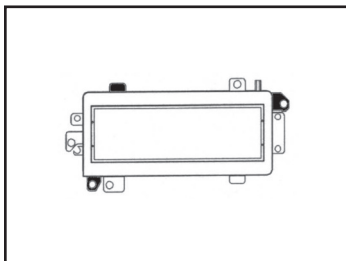

(Figure B)

## **Dodge Caravan/Chrysler Town & Country/Plymouth Voyager 1996-2000**

1. Pull the ashtray forward. Unsnap the plastic trim piece located below the radio trim bezel and remove (2) Phillips screws exposed. (Figure A)
2. Remove (2) Phillips screws above the radio opening.
3. Unclip the dash trim bezel, disconnect the climate control wiring and remove the bezel.
4. Remove (2) 3/8" hex-head screws securing the factory radio and disconnect the wiring.
5. Cut and remove all mounting tabs on the radio housing EXCEPT the shaded tabs. (Figure B)

*Continue to kit assembly*

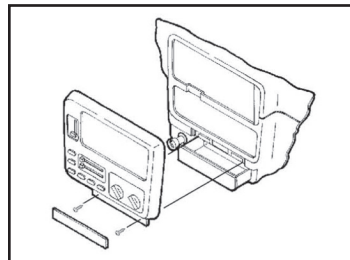

(Figure A)

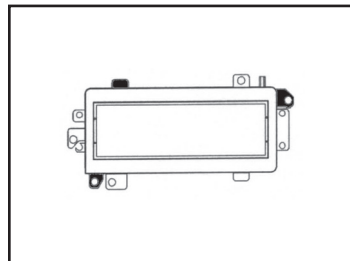

(Figure B)

### Dodge Charger/Plymouth Turismo 1983-1987

1. Unclip the radio trim bezel and remove.
2. Remove (2) 3/8" hex-head screws securing the factory radio and disconnect the wiring.
3. Cut and remove all mounting tabs on the radio housing EXCEPT the shaded tabs. (Figure B)

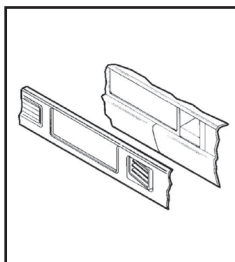

(Figure A)

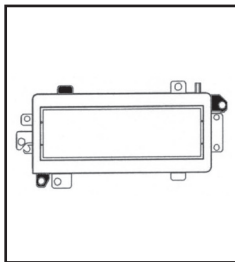

(Figure B)

Continue to kit assembly

### Dodge Dakota 1987-1996

1. Remove (8) torx-head screws from the dash trim bezel.
2. Remove (2) Phillips screws from the lower steering column trim and remove.
3. Remove (1) Phillips screw from each side of the steering column.
4. Unclip the dash trim bezel and remove. (Figure A)
5. Remove (2) Phillips screws securing the factory radio and disconnect the wiring.
6. Cut and remove all mounting tabs on the radio housing EXCEPT the shaded tabs. (Figure B)

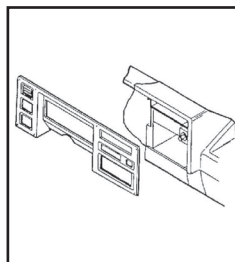

(Figure A)

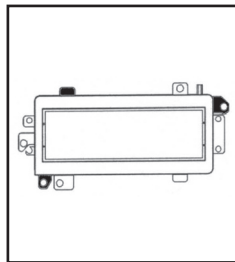

(Figure B)

Continue to kit assembly

### Dodge Dakota 1997-2000

1. Unclip the entire dash trim bezel. (Figure A)
2. Remove (2) 3/8" hex-head screws securing the factory radio and disconnect the wiring.
3. Cut and remove all mounting tabs on the radio housing EXCEPT the shaded tabs. (Figure B)

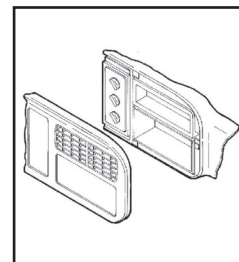

(Figure A)

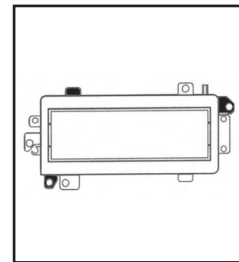

(Figure B)

Continue to kit assembly

## Dodge Daytona 1990-1993

1. Pull out on the dash trim bezel and remove. (Figure A)
2. Remove (2) screws from each side of the lower console (this will allow easier radio removal).
3. Remove (2) screws securing the factory radio and disconnect the wiring.
4. Cut and remove all mounting tabs on the radio housing EXCEPT the shaded tabs. (Figure B)

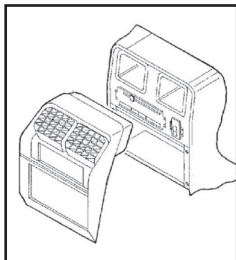

(Figure A)

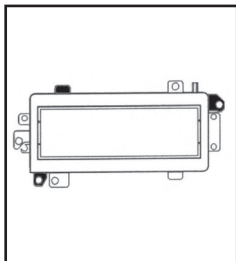

(Figure B)

*Continue to kit assembly*

## Dodge Durango 1997-2000

1. Unclip the entire dash trim bezel. (Figure A)
2. Remove (2) 3/8" hex-head screws securing the factory radio and disconnect the wiring.
3. Cut and remove all mounting tabs on the radio housing EXCEPT the shaded tabs. (Figure B)

*Continue to kit assembly*

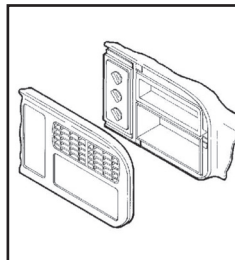

(Figure A)

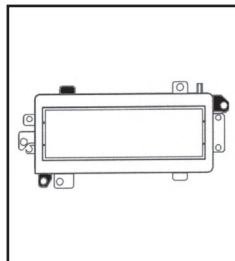

(Figure B)

## Dodge Neon/Plymouth Neon 1994-1999

1. Remove the ashtray. Unclip the radio trim bezel and remove. (Figure A)
2. Remove (2) 3/8" hex-head screws securing the factory radio and disconnect the wiring.
3. Cut and remove all mounting tabs on the radio housing EXCEPT the shaded tabs. (Figure B)

*Continue to kit assembly*

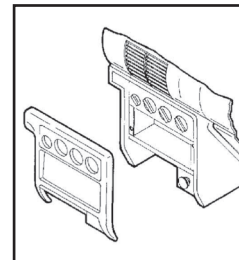

(Figure A)

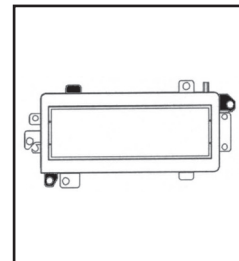

(Figure B)

### Dodge Omni/024/Rampage 1978-1982, Plymouth Horizon/TC3 1978-1982/ Scamp 1983-1984

1. Remove (7) Phillips screws from the dash trim bezel and remove the bezel. (Figure A)
2. Remove (2) 3/8" hex-head screws securing the factory radio and disconnect the wiring.
3. Cut and remove all mounting tabs on the radio housing EXCEPT the shaded tabs. (Figure B)

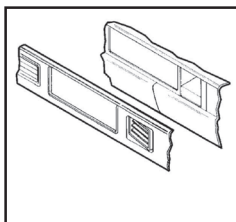

(Figure A)

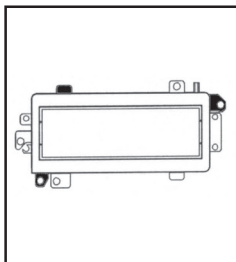

(Figure B)

*Continue to kit assembly*

### Dodge Pickup/Ramcharger/ Plymouth Trailduster 1974-1980

1. Remove (4) Phillips screws from the top edge of the dash trim bezel. (Figure A)
2. Remove (7) Phillips screws from the face of the dash trim bezel.
3. Remove (3) Phillips screws under the dash trim bezel.
4. Unclip the bezel and remove. Remove (2) 3/8" hex-head screws securing the factory radio and disconnect the wiring.
5. Cut and remove all mounting tabs on the radio housing EXCEPT the shaded tabs. (Figure B)

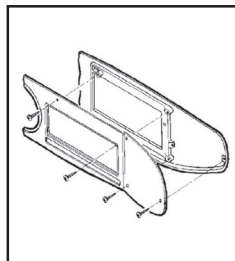

(Figure A)

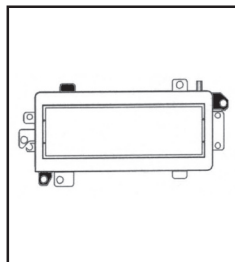

(Figure B)

*Continue to kit assembly*

### Dodge Pickup/Ramcharger 1981-1993, Plymouth Trailduster 1981

1. Remove (5) Phillips screws from the edge of the dash trim bezel.
2. Remove (1) Phillips screw above the radio opening.
3. Pry out on the bottom edge of the bezel and remove. (Figure A)
4. Remove (2) 3/8" hex-head screws securing the factory radio and disconnect the wiring.
5. Cut and remove all mounting tabs on the radio housing EXCEPT the shaded tabs. (Figure B)

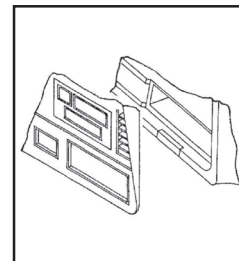

(Figure A)

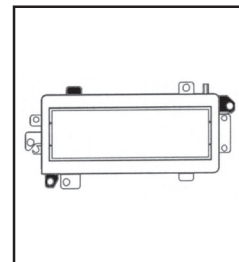

(Figure B)

*Continue to kit assembly*

## Dodge Ram 1994-2001

1. Remove the ashtray. Remove (2) Phillips screws exposed in the ashtray cavity and remove the ashtray bracket. (Figure A)
2. Remove the cupholder. Remove (2) Phillips screws exposed in the cup holder cavity and remove the cupholder bracket. (Figure A)
3. Unclip the dash trim bezel, pull the bezel over the steering column and remove.
4. Remove (2) 3/8" hex-head screws securing the factory radio and disconnect the wiring.
5. Cut and remove all mounting tabs on the radio housing EXCEPT the shaded tabs. (Figure B)

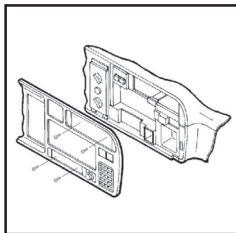

(Figure A)

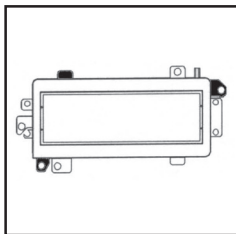

(Figure B)

*Continue to kit assembly*

## Dodge Shadow/Plymouth Sundance 1987-1994

1. Remove the ashtray. Unclip the dash trim bezel and remove. (Figure A)
2. Remove (1) Phillips screw from the console side trim and remove.
3. Remove (2) 3/8" hex-head bolts securing the factory radio and disconnect the wiring.
4. Cut and remove all mounting tabs on the radio housing EXCEPT the shaded tabs. (Figure B)

*Continue to kit assembly*

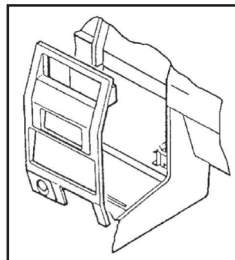

(Figure A)

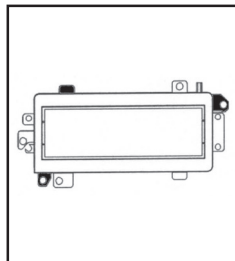

(Figure B)

## Dodge Spirit/Plymouth Acclaim 1989-1995

1. Unclip the dash trim bezel and remove. Remove the screws securing the side console trim pieces. (Figure A)
2. Pull the right trim piece out and remove (1) hex-head bolt exposed.
3. Remove (1) hex-head bolt securing the bottom-left corner of the factory radio and disconnect the wiring.
4. Cut and remove all mounting tabs on the radio housing EXCEPT the shaded tabs. (Figure B)

*Continue to kit assembly*

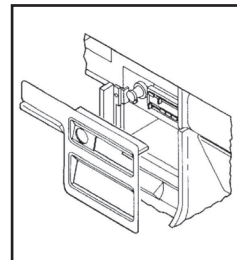

(Figure A)

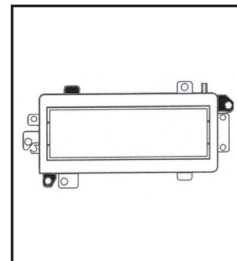

(Figure B)



## Dodge Van/Plymouth Van 1978-2003

1. Open the glove box and remove (2) Phillips screws exposed.
2. Remove (5) Phillips screws from the bottom of the dash trim bezel.
3. Unclip the top edge of the bezel and remove.
4. Remove (2) 3/8" hex-head screws securing the factory radio and disconnect the wiring.
5. Cut and remove all mounting tabs on the radio housing EXCEPT the shaded tabs.

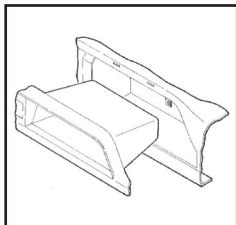

(Figure A)

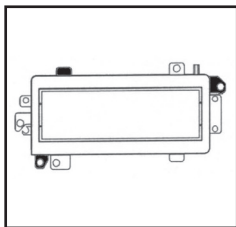

(Figure B)

### For 1998-2003 Dodge Van

1. Unclip and remove entire panel surrounding radio and instrument cluster.
2. Remove (2) 3/8" hex-head screws securing the factory radio and disconnect the wiring.

*Continue to kit assembly*

## Ford Aerostar 1985-1991

1. Remove (2) Phillips screws from the base of the dash panel. (Figure A)
2. Pry down on the (2) tabs located at the top of the radio trim bezel and remove the bezel. (Figure A)
3. Remove (4) screws securing the factory radio and disconnect the wiring.
4. Cut and remove all mounting tabs on the radio housing EXCEPT the shaded tabs. (Figure B)

*Continue to kit assembly*

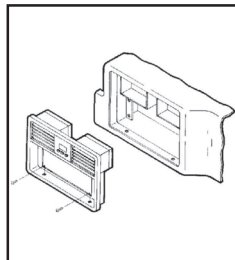

(Figure A)

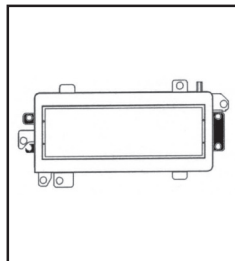

(Figure B)

## Ford Bronco II/Ranger (mini) 1985-1988

1. Remove (4) Phillips screws from the top edge of the dash trim bezel. (Figure A)
2. Remove the light switch knob, cigarette lighter and ashtray.
3. Unsnap the molding under the dash trim bezel and remove (4) screws exposed. (Figure A)
4. Remove (4) screws securing the factory radio and disconnect the wiring.
5. Cut and remove all mounting tabs on the radio housing EXCEPT the shaded tabs. (Figure B)

*Continue to kit assembly*

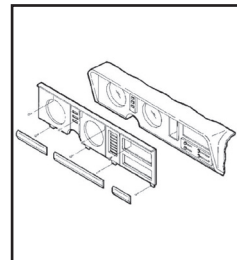

(Figure A)

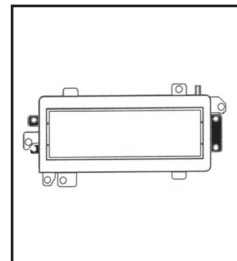

(Figure B)

## Ford Crown Victoria/ LTD 1979-1990, Mercury Grand Marquis/Marquis 1979-1990

1. Open the ashtray and remove (2) Phillips screws exposed. (Figure A)
2. Remove the dash trim bezel.
3. Remove (4) screws securing the factory radio and disconnect the wiring.
4. Cut and remove all mounting tabs on the radio housing EXCEPT the shaded tabs. (Figure B)

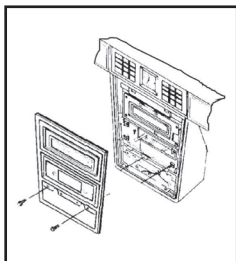

(Figure A)

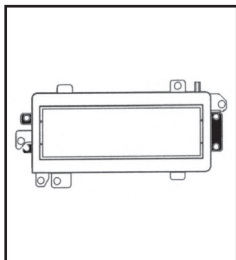

(Figure B)

*Continue to kit assembly*

## Ford Thunderbird/Mercury Cougar 1985-1988

1. Remove (2) screws from the top of the dash trim bezel. (Figure A)
2. Open the ashtray and remove (2) screws exposed in the ashtray cavity. (Figure A)
3. Remove the dash trim bezel. Remove (4) screws securing the factory radio and disconnect the wiring.
4. Cut and remove all mounting tabs on the radio housing EXCEPT the shaded tabs. (Figure B)

*Continue to kit assembly*

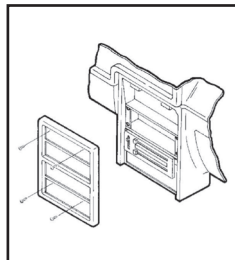

(Figure A)

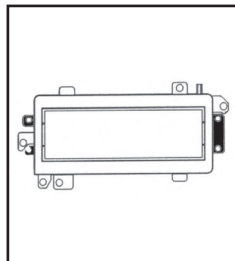

(Figure B)

## Jeep Cherokee 1997-2001

1. Unclip the dash trim bezel. (Figure A)
2. Remove (2) #10 hexhead screws securing the factory radio and disconnect the wiring.
3. Cut and remove all mounting tabs on the radio housing EXCEPT the shaded tabs. (Figure B)

*Continue to kit assembly*

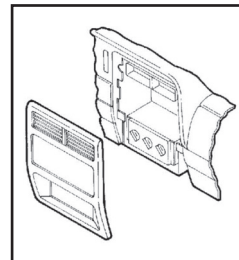

(Figure A)

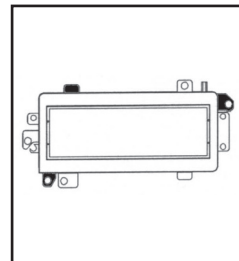

(Figure B)

## Jeep Grand Cherokee 1993-1995

1. Remove (2) Phillips screws from the bottom of the dash trim bezel. (Figure A)
2. Remove (2) Phillips screws above the radio opening. (Figure A)
3. Remove (2) Phillips screws to the left of the steering column. (Figure A)
4. Remove (1) Phillips screw to the right of the steering column. Unclip the dash trim bezel and disconnect the wiring.
5. Cut and remove all mounting tabs on the radio housing EXCEPT the shaded tabs. (Figure B)

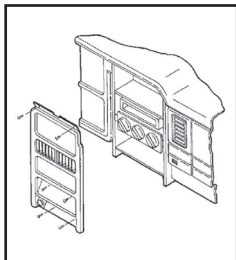

(Figure A)

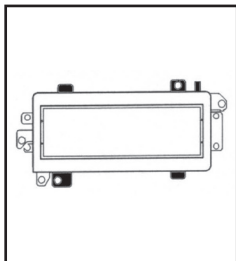

(Figure B)

Continue to kit assembly

## Jeep Grand Cherokee 1996-1998

1. Unsnap the climate control/wiper control trim panel and remove.
2. Remove (5) Phillips screws from the top of the radio/instrument cluster trim bezel.
3. Remove (4) Phillips screws from the bottom of the radio/instrument cluster trim bezel.
4. Pry out on the bottom edge of the bezel and remove. (Figure A)
5. Remove (2) 3/8" hex-head screws securing the factory radio and disconnect the wiring.
6. Cut and remove all mounting tabs on the radio housing EXCEPT the shaded tabs. (Figure B)

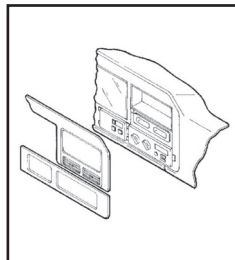

(Figure A)

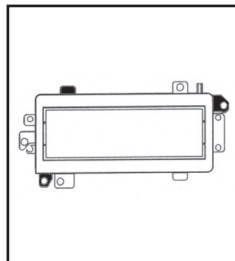

(Figure B)

Continue to kit assembly

## Jeep Wrangler 1997-2002

1. Remove the ashtray and (1) Phillips screw exposed in the ashtray cavity. (Figure A)
2. Pry out on the top cover of the instrument panel and remove (2) Phillips screws exposed.
3. Pry out on the bottom edge of the dash trim bezel and remove.
4. Remove (2) 3/8" hex-head screws securing the factory radio and disconnect the wiring.
5. Cut and remove all mounting tabs on the radio housing EXCEPT the shaded tabs. (Figure B)

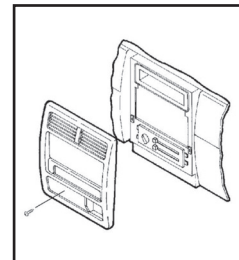

(Figure A)

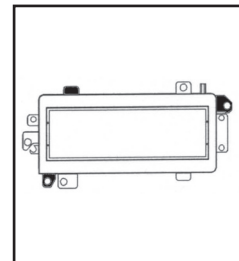

(Figure B)

Continue to kit assembly

## Lincoln Continental 1985-1987

1. Remove (2) #8 Phillips screws below the radio opening.  
(Figure A)
2. Open the ashtray and remove (2) #8 Phillips screws (it is NOT necessary to remove the center screw).  
(Figure A)
3. Unclip the dash trim bezel and remove.
4. Remove (4) hex-head screws securing the factory radio and disconnect the wiring.  
(Figure B)
5. Cut and remove all mounting tabs on the radio housing EXCEPT the shaded tabs.  
(Figure B)

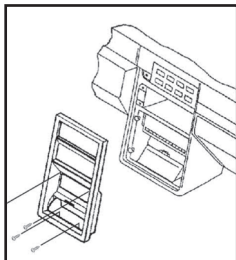

(Figure A)

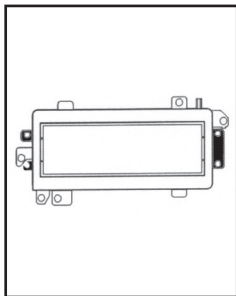

(Figure B)

*Continue to kit assembly*

## Lincoln Mark VII 1984-1989

1. Pry out on the dash trim bezel and remove.  
(Figure A)
2. Remove (4) 5mm hex-head sheet metal screws securing the factory radio and disconnect the wiring.
3. Cut and remove all mounting tabs on the radio housing EXCEPT the shaded tabs.  
(Figure B)

*Continue to kit assembly*

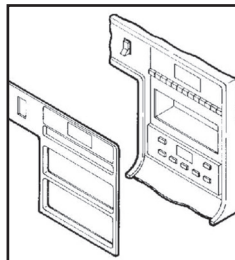

(Figure A)

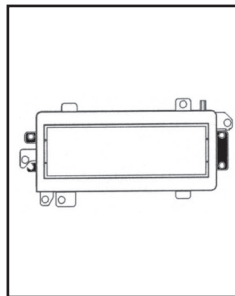

(Figure B)

## DIN radio provision

1. Slide the DIN cage into the radio housing and secure by bending the metal locking tabs down.
2. Slide the aftermarket radio into the cage until secure. (Figure A)

*Continue to final kit assembly*

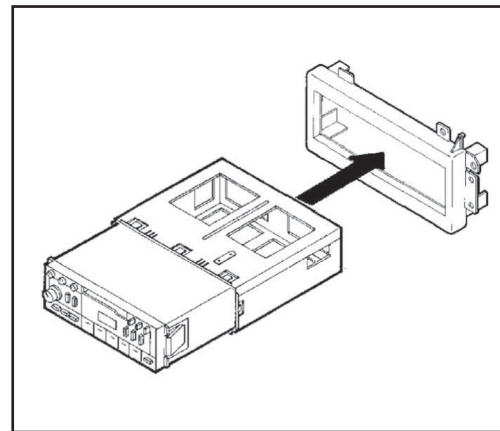

(Figure A)



## Kit Assembly INST-FD-CR

### Final kit assembly

1. Locate the factory wiring harness in the dash. Metra recommends using the proper mating adapter from Metra or AXXESS. Test the radio for proper operation.

#### Ford/Lincoln/Mercury

2. Mount the radio/kit assembly to the sub-dash with (4) screws previously removed. (Figure A)
3. Reassemble dash in reverse order of disassembly.

#### Chrysler/Dodge/Plymouth/Eagle/Jeep

*(excluding Grand Cherokee 1993-1995, Cirrus, Stratus, Breeze, Sebring, Avenger)*

2. Mount the radio/kit assembly to the sub-dash with (2) 3/8" hex-head screws previously removed. (Figure B)
3. Reassemble dash in reverse order of disassembly.

#### Jeep Grand Cherokee 1993-1995

2. Mount the radio/kit assembly to the sub-dash with (2) screws previously removed. (Figure C)
3. Reassemble dash in reverse order of disassembly.

*Continued on the next page*

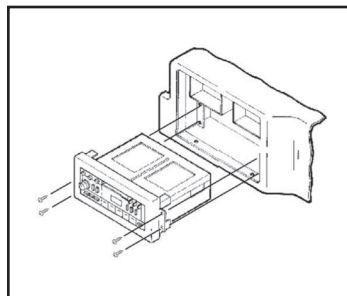

(Figure A)

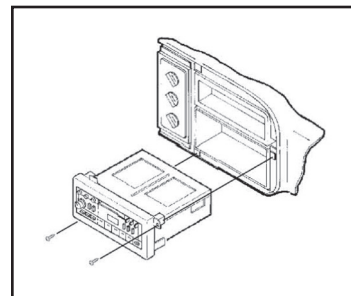

(Figure B)

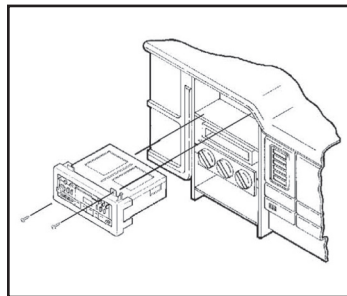

(Figure C)



## Kit Assembly INST-FD-CR

### Final kit assembly

#### Chrysler Cirrus, Dodge Stratus, Plymouth Breeze

2. Mount the radio/kit assembly to the sub-dash with (2) screws previously removed. (Figure D)
3. Reassemble dash in reverse order of disassembly.

#### Chrysler Sebring, Dodge Avenger

2. Remove the top-left screw from the metal dash housing.
3. Mount the radio/kit assembly to the sub-dash with (2) screws previously removed. (Figure E)
4. Replace the metal housing screw through the top Support Spacer. (Figure E)
5. Reassemble dash in reverse order of disassembly.

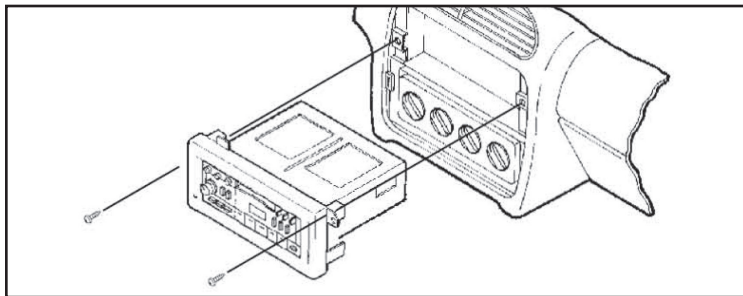

(Figure D)

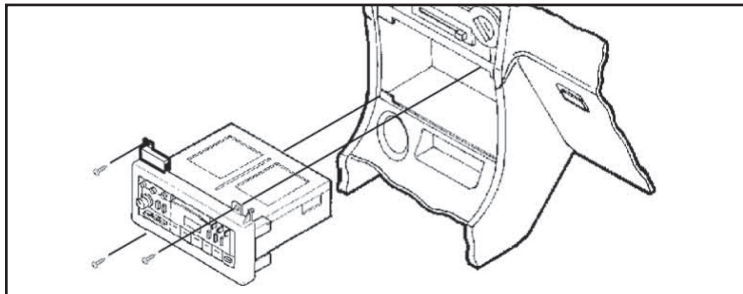

(Figure E)





Installation instructions for part INST-FD-CR



## IMPORTANT

If you are having difficulties with the installation of this product, please call our Tech Support line at **1-800-253-TECH**. Before doing so, look over the instructions a second time, and make sure the installation was performed exactly as the instructions are stated. Please have the vehicle apart and ready to perform troubleshooting steps before calling.



### KNOWLEDGE IS POWER

Enhance your installation and fabrication skills by enrolling in the most recognized and respected mobile electronics school in our industry. Log onto [www.installerinstitute.com](http://www.installerinstitute.com) or call 800-354-6782 for more information and take steps toward a better tomorrow.



**Metra recommends MECP certified technicians**

REV 10/19/2016 INST-FD-CR





## Instrucciones de instalación para la pieza INST-FD-CR

# Ford/Chrysler 1974-2003 INST-FD-CR

### INSTRUCCIONES DE INSTALACIÓN

---

#### Sección 1:

- 99-5700
- AW-509FD
- CF-509FD

#### Sección 2:

- 99-6700

### HERRAMIENTAS REQUERIDAS

---

Consulte la página del título de cada sección.

### APLICACIÓN GENERAL

---

**99-5700/AW-509FD/**

**CF-509FD**

Ford/Jeep/Lincoln/Mercury

**99-6700**

Chrysler/Dodge/Eagle/

Ford/Jeep/Lincoln/

Mercury/Plymouth

*INST-FD-CR es una colección de folletos de instrucciones de instalación. Usa la vista general de la aplicación cuando la selección de los que la selección de instrucciones de instalación para su uso. Cada sección se configura como un capítulo con su propia tabla de contenidos.*

### Índice

<b>Sección 1</b> .....	2
– Desmontaje del tablero .....	3-11
– Ensamble del kit .....	12-13
<b>Sección 2</b> .....	14
– Desmontaje del tablero .....	15-28
– Ensamble del kit .....	28
– Ensamble del kit final .....	29-30

---

**¡PRECAUCIÓN!** Todos los accesorios, interruptores, paneles de controles de clima y especialmente las luces del indicador de las bolsas de aire deben estar conectados antes ciclar la ignición. Además, no quite el radio de fábrica con la llave en la posición o de encendido ni con el vehículo funcionando.



## Sección 1

Ford/Jeep  
1975-1996

### 99-5700, AW-509FD/ CF-509FD

#### CARACTERÍSTICAS DEL KIT

- Provisión de radio DIN
- Provisión de radio ISO DIN (*select vehicles*)

#### COMPONENTES DEL KIT

- A) Carcasa del radio #1 • B) Carcasa del radio #2
- C) Conjunto de soportes #1 (*Econoline*) • D) Soportes #2 (*Escort/Lynx*) • E) Espaciador conjunto #1
- F) (4) tornillos Phillips #6 X 3/8" de cabeza troncocónica • G) (2) #6 Tornillos autorroscantes

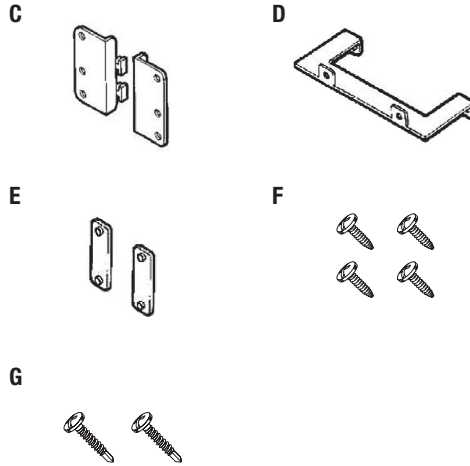
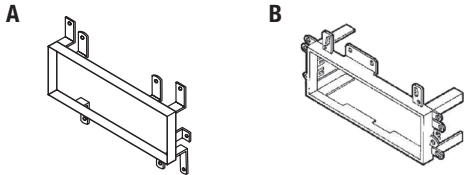

#### HERRAMIENTAS REQUERIDAS

- Destornillador Phillips • Herramientas de corte
- Llaves de remoción Metra 86-5618

## Aplicaciones

### Ford

Aerostar.....	1985-1991
Bronco (full).....	1987-1991
Bronco.....	1980-1986
Bronco II.....	1985-1988
Crown Victoria.....	1979-1990
Econoline.....	1975-1991
Esoort.....	1985-1990
F-Series Pickup.....	1987-1991
F-Series Pickup.....	1980-1986
Festiva.....	1988-1993
LTD.....	1979-1990
Ranger (mini).....	1985-1988
Taurus.....	1986-1989
Tempo.....	1985-1988
Thunderbird.....	1985-1988

### Jeep

Cherokee.....	1984-1995
Cherokee.....	1996
Comanche.....	1986-1992
Grand Wagoneer.....	1987-1992

### Ford Aerostar 1985-1991

Wagoneer ..... 1984-1996

Wrangler ..... 1986-1996

#### Lincoln

Continental ..... 1985-1987

Mark VII ..... 1984-1989

Town Car ..... 1984-1989

#### Mercury

Cougar ..... 1985-1988

Grand Marquis ..... 1979-1990

Lynx ..... 1985-1990

Marquis ..... 1979-1990

Sable ..... 1986-1989

Topaz ..... 1985-1988

Tracer (hatch) ..... 1989-1990

## Indice

**Desmontaje del tablero** ..... 3-11

#### Ensamble del kit

– Provisión de radio DIN ..... 12-13

– ISO Provisión de radio DIN ..... 12-13

1. Retire (2) tornillos Phillips de labase del marco de terminación del tablero. (Figura A)
2. Levante haciendo palanca en las (2) lengüetas que se encuentran en la parte superior del marco de terminación del tablero y retire el marco.
3. Retire (4) tornillos que sujetan la unidad central de fábrica y desconecte el cableado.
4. Corte y retire todas las lengüetas de montaje del alojamiento del radio, SALVO las lengüetas "D" y "F". (Figura B)
5. Localizar Spacer Set #1 (los espaciadores deben ser colocados detrás de las lengüetas de montaje durante la instalación).

*Continuará al ensamble del kit*

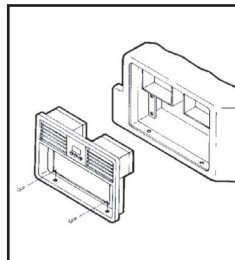

(Figura A)

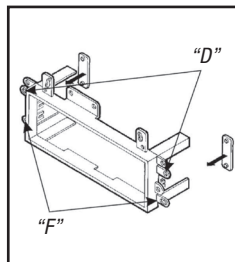

(Figura B)

*Lengüetas de montaje se pueden identificar por la letra estampada en la parte posterior de cada lengüeta.*

### Ford Bronco/Pickup 1980-1986

1. Retire (2) tornillos del borde superior del marco de terminación del tablero. (Figura A)
2. Jale la parte superior del marco hacia afuera, desenganche la base y retire el marco. Cuando NO haya una unidad central de fábrica, trace los (4) orificios de montaje y la abertura del radio en el marco.

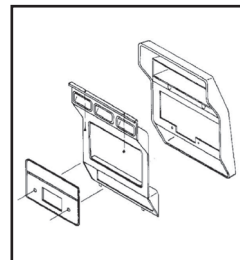

(Figura A)

3. Perfore los orificios, corte la abertura y coloque (4) ganchos en U sobre las posiciones de montaje.
4. Corte y retire todas las pestañas de la carcasa de la radio #1, SALVO las lengüetas "B". (Figura B)

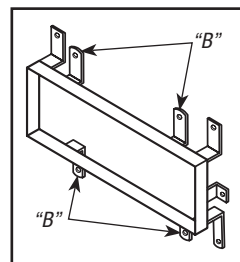

(Figura B)

*Continuará al ensamble del kit*

*Lengüetas de montaje se pueden identificar por la letra estampada en la parte posterior de cada lengüeta.*

## Ford Bronco (tamaño completo) F-Series Pickup 1987-1991

1. Jale con cuidado y retire el marco de terminación del tablero. (Figura A)
2. Retire (4) tornillos que sujetan la unidad central de fábrica y desconecte el cableado.
3. Corte y retire todas las lengüetas de montaje del alojamiento del radio n.º 2, SALVO las lengüetas "D" y "F". (Figura B)
4. Localizar Spacer Set #1 (los espaciadores deben ser colocados detrás de las lengüetas de montaje durante la instalación).

*Continuará al ensamble del kit*

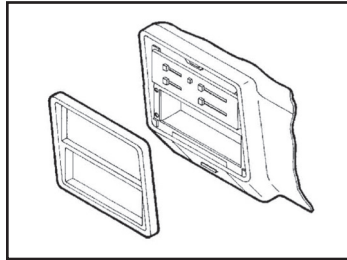

(Figura A)

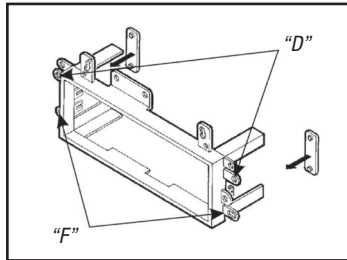

(Figura B)

*Lengüetas de montaje se pueden identificar por la letra estampada en la parte posterior de cada lengüeta.*

## Ford Bronco II/Ranger 1985-1988

1. Retire (4) tornillos Phillips del borde superior del marco de terminación del tablero. (Figura A)
2. Retire la perilla del interruptor de luces, el encendedor y el cenicero.
3. Quite a presión la moldura que se encuentra debajo del marco de terminación del tablero y retire (4) tornillos expuestos.
4. Retire (4) tornillos que sujetan la unidad central de fábrica y desconecte el cableado.
5. Corte y retire todas las pestañas de la carcasa de la radio #2, excepto pestañas "D" y "F". (Figura B)
6. Localizar Spacer Set #1 (los espaciadores deben ser colocados detrás de las lengüetas de montaje durante la instalación).

*Continuará al ensamble del kit*

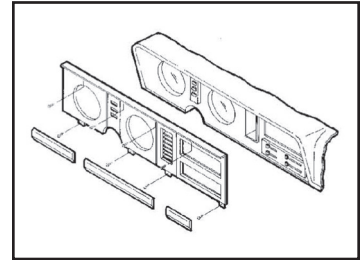

(Figura A)

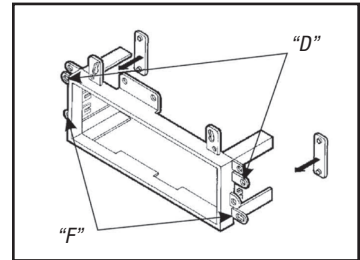

(Figura B)

### Ford Crown Victoria/LTD, Mercury Grand Marquis/Marquis 1979-1990

1. Abra el cenicero y retire (2) tornillos Phillips que sujetan el marco de terminación del tablero. (Figura A)
2. Retire (4) tornillos que sujetan la unidad central de fábrica y desconecte el cableado.
3. Corte y retire todos los soportes de montaje de la carcasa de la radio #2, SALVO las lengüetas "D" y "F". (Figura B)
4. Localizar Spacer Set #1 (los espaciadores deben ser colocados detrás de las lengüetas de montaje durante la instalación).

*Continuará al ensamble del kit*

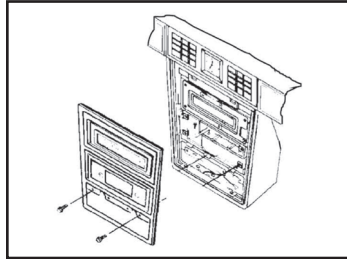

(Figura A)

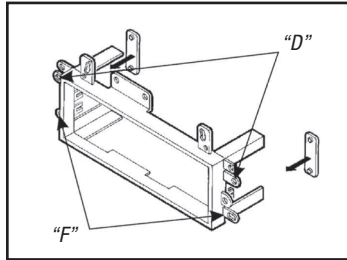

(Figura B)

*Lengüetas de montaje se pueden identificar por la letra estampada en la parte posterior de cada lengüeta.*

### Ford Econoline 1975-1991

1. Retire (3) tornillos del borde inferior del marco de terminación del tablero. (Figura A)
2. Retire (2) tornillos que se encuentran arriba de la abertura del radio. Suelte la esquina derecha del bisel ajuste de la rociada, desconecte el cableado del encendedor de cigarrillos y retire la cubierta. (Figura A)
3. Retire los tornillos que sujetan la unidad central de fábrica y desconecte el cableado.
4. Corte y retire todas las lengüetas de montaje de la carcasa de la radio #2. Deslizar el soporte de Set #1 en las ranuras de la carcasa de la radio. (Figura B)

*Continuará al ensamble del kit*

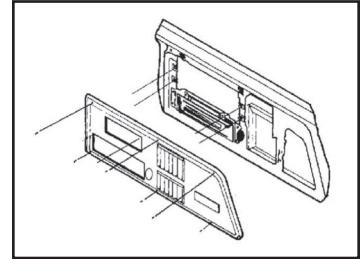

(Figura A)

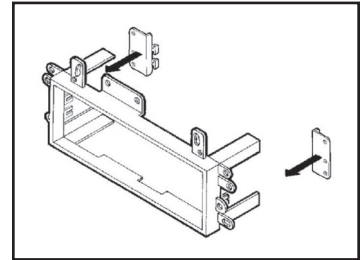

(Figura B)

*Lengüetas de montaje se pueden identificar por la letra estampada en la parte posterior de cada lengüeta.*

**Ford Escort/Mercury Lynx  
1985-1990**

1. Retire (4) tornillos del borde superior del marco de terminación del tablero. (Figura A)
2. Retire (2) tornillos del borde inferior del marco de terminación del tablero. (Figura A)
3. Retire las perillas de control de clima y retire el marco.
4. Retire (4) tornillos de cabeza hexagonal que sujetan la unidad central de fábrica y desconecte el cableado.
5. Corte y retire todos los soportes de montaje de la carcasa de la radio #2, SALVO las lengüetas "B". (Figura B)
5. Soporte de montaje #2 para la parte inferior de la carcasa con (2) tornillos Phillips n.º 8 x 3/4 in suministrados.

*Continuará al ensamble del kit*

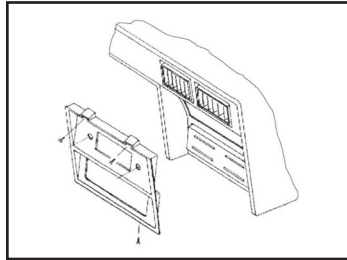

(Figura A)

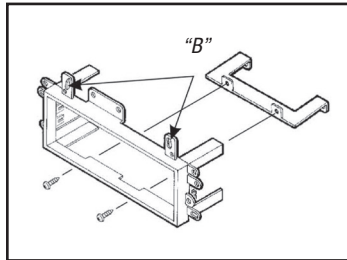

(Figura B)

*Lengüetas de montaje se pueden identificar por la letra estampada en la parte posterior de cada lengüeta.*

**Ford Festiva  
1988-1993**

1. Retire (4) tornillos Phillips de la parte inferior del marco de terminación del tablero.
2. Retire el marco. Retire (2) tornillos que sujetan la unidad central de fábrica y desconecte el cableado. Extraiga el embellecedor. (Figura A)
3. Corte y retire todas las lengüetas de montaje de la carcasa de la radio #1, SALVO las lengüetas "C". (Figura B)

*Continuará al ensamble del kit*

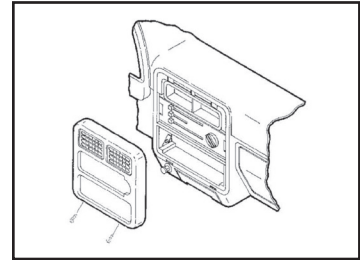

(Figura A)

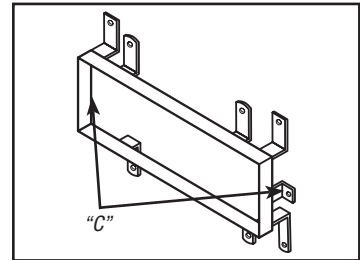

(Figura B)

*Lengüetas de montaje se pueden identificar por la letra estampada en la parte posterior de cada lengüeta.*

**Ford Taurus/Mercury  
Sable 1986-1989**

1. Retire (1) tornillo de cabeza hexagonal de 7mm de la parte inferior del marco de terminación del radio. Desenganche con cuidado el marco y desconecte el conductor de alimentación del interruptor de la antena. (Figura A)

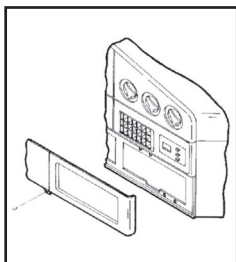

(Figura A)

2. Retire (4) tornillos que sujetan la unidad central de fábrica y desconecte el cableado.

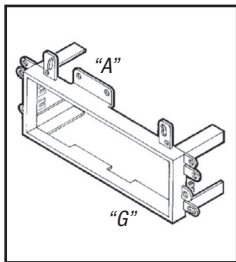

(Figura B)

3. Corte y retire todas las lengüetas de montaje de la carcasa de la radio #2, SALVO las lengüetas "A" y "G". (Figura B)

*Continuará al  
ensamble del kit*

*Lengüetas de montaje se pueden  
identificar por la letra estampada en  
la parte posterior de cada lengüeta.*

**Ford Tempo/Mercury  
Topaz 1985-1988**

1. Retire el cenicero soltando la lengüeta de liberación que se encuentra en la parte posterior del soporte del cenicero.
2. Retire (2) tornillos del borde inferior del marco de terminación del tablero. Desenganche el borde superior del marco y retírelo. (Figura A)

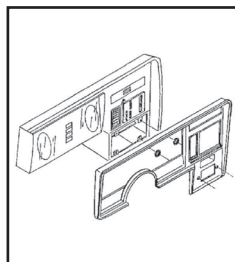

(Figura A)

3. Retire (4) tornillos que sujetan la unidad central de fábrica y desconecte el cableado.
4. Corte y retire todas las lengüetas de montaje de la carcasa de la radio #1, SALVO las lengüetas "A". (Figura B)

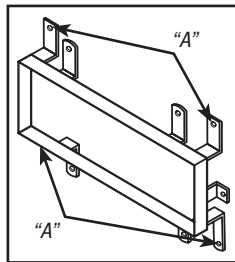

(Figura B)

*Continuará al ensamble  
del kit*

*Lengüetas de montaje se pueden  
identificar por la letra estampada en  
la parte posterior de cada lengüeta.*

**Ford Thunderbird/Mercury  
Cougar 1985-1988**

1. Retire (2) tornillos de la parte superior del marco de terminación del tablero. (Figura A)
2. Abra el cenicero y retire (2) tornillos del hueco del cenicero.
3. Retire (4) tornillos que sujetan la unidad central de fábrica y corte y retire todas las pestañas de la carcasa de la radio #2, excepto pestañas "D" y "F". (Figura B)

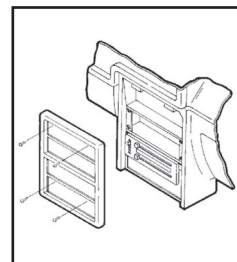

(Figura A)

4. Localizar Spacer Set #1 (los espaciadores deben ser colocados detrás de las lengüetas de montaje durante la instalación).

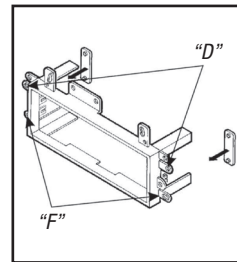

(Figura B)

*Continuará al ensamble  
del kit*

*Lengüetas de montaje se pueden  
identificar por la letra estampada en  
la parte posterior de cada lengüeta.*

### **Jeep Cherokee 1984-1995/ Comanche 1986-1992/ Wagoneer 1984-1996**

1. Quite a presión el panel de terminación de la columna de la dirección y retírelo. (Figura A)
2. Retire (4) tornillos del marco de terminación del tablero y retire el marco. (Figura A)
3. Retire (2) tornillos que sujetan la unidad central de fábrica y desconecte el cableado.
4. Corte y retire todas las lengüetas de montaje de la carcasa de la radio #2, SALVO las lengüetas "E". (Figura B)

*Continuará al ensamble del kit*

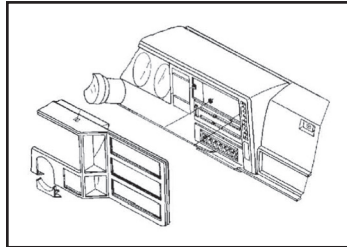

(Figura A)

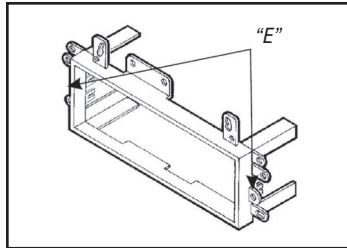

(Figura B)

*Lengüetas de montaje se pueden identificar por la letra estampada en la parte posterior de cada lengüeta.*

### **Jeep Cherokee 1996**

1. Retire (3) tornillos de cabeza Torx de los paneles de terminación de la columna de la dirección.
2. Desenrosque la palanca de dirección de inclinación y desabroche los paneles de ajuste. Retire (4) tornillos del marco de terminación del tablero y retire el marco. (Figura A)
3. Retire (2) tornillos que sujetan la unidad central de fábrica y desconecte el cableado.
4. Corte y retire todas las lengüetas de montaje de la carcasa de la radio #2, SALVO las lengüetas "E". (Figura B)

*Continuará al ensamble del kit*

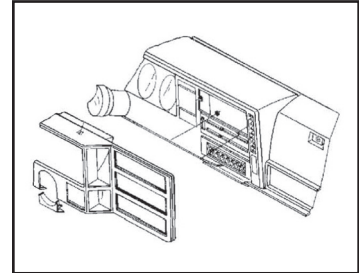

(Figura A)

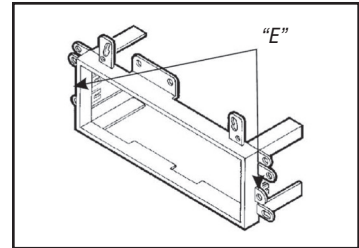

(Figura B)

*Lengüetas de montaje se pueden identificar por la letra estampada en la parte posterior de cada lengüeta.*



## Jeep Grand Wagoneer 1987-1992

1. Desenganche con cuidado el marco de terminación del tablero. (Figura A)
2. Retire (2) tornillos que sujetan la unidad central de fábrica y desconecte el cableado.
3. Corte y retire todas las lengüetas de montaje de la carcasa de la radio #2, SALVO las lengüetas "E". (Figura B)

*Continuará al ensamble del kit*

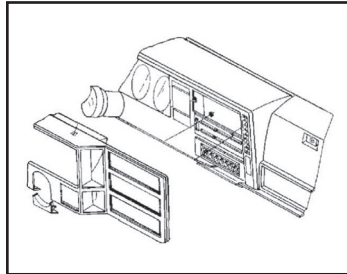

(Figura A)

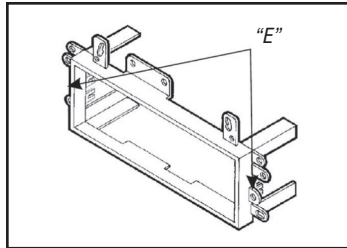

(Figura B)

*Lengüetas de montaje se pueden identificar por la letra estampada en la parte posterior de cada lengüeta.*

## Jeep Wrangler 1986-1996

1. Retire (6) tornillos Phillips de la parte frontal del marco de terminación del tablero. (Figura A)
2. Retire el marco. Retire (2) tornillos que sujetan la unidad central de fábrica y desconecte el cableado.
3. Corte y retire todos los soportes de montaje de la carcasa de la radio #2, SALVO las lengüetas "B". (Figura B)

*Continuará al ensamble del kit*

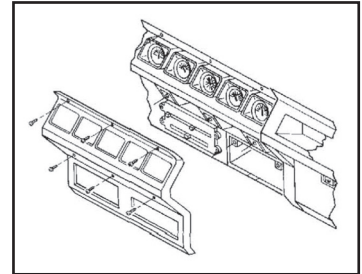

(Figura A)

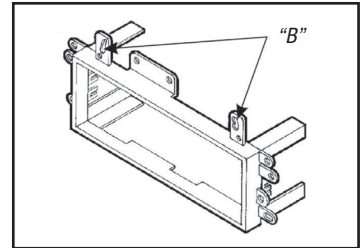

(Figura B)

*Lengüetas de montaje se pueden identificar por la letra estampada en la parte posterior de cada lengüeta.*

### Lincoln Continental 1985-1987

1. Retire (2) tornillos Phillips #8, encuentran debajo de la abertura del radio. (Figura A)
2. Abra el cenicero y retire (2) tornillos Phillips #8 expuestos (NO es necesario retirar el tornillo central). (Figura A)
3. Desenganche y retire el marco de terminación del tablero.
4. Retire (4) tornillos de cabeza hexagonal que sujetan la unidad central de fábrica y desconecte el cableado.
5. Corte y retire todos los soportes de montaje de la carcasa de la radio #2, SALVO las lengüetas "D" y "F". (Figura B)
6. Localizar Spacer Set #1 (los espaciadores deben ser colocados detrás de las lengüetas de montaje durante la instalación).

*Continuará al ensamble del kit*

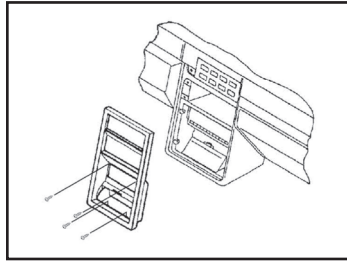

(Figura A)

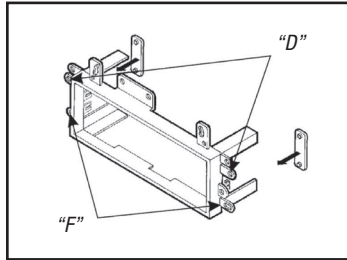

(Figura B)

*Lengüetas de montaje se pueden identificar por la letra estampada en la parte posterior de cada lengüeta.*

### Lincoln Mark VII 1984-1989

1. Haga palanca suavemente sobre el bisel ajuste de la rociada y quitar. (Figura A)
2. Retire (4) tornillos de metal de cabeza hexagonal de 5mm que sujetan la unidad central de fábrica y desconecte el cableado.
3. Corte y retire todos los soportes de montaje de la carcasa de la radio #2, SALVO las lengüetas "D" y "F". (Figura B)
4. Localizar Spacer Set #1 (los espaciadores deben ser colocados detrás de las lengüetas de montaje durante la instalación).

*Continuará al ensamble del kit*

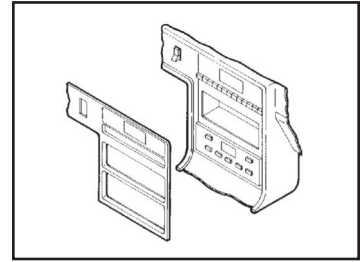

(Figura A)

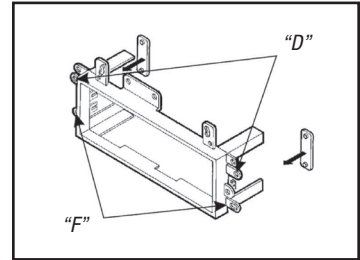

(Figura B)

*Lengüetas de montaje se pueden identificar por la letra estampada en la parte posterior de cada lengüeta.*

### **Lincoln Town Car 1984-1989**

1. Retire (3) tornillos Phillips #8 de la parte inferior del marco de terminación del radio. (Figura A)
2. Quite la tira de plástico que se encuentra arriba del marco y retire (3) tornillos Phillips expuestos. (Figura A)
3. Jale con cuidado hacia afuera el marco de terminación del grupo de instrumentos del tablero y retire el marco de terminación del radio.
4. Retire (3) tornillos de cabeza hexagonal que sujetan la unidad central de fábrica y desconecte el cableado.
5. Corte y retire todas las lengüetas de montaje de la carcasa de la radio #2, SALVO las lengüetas "D" and "F". (Figura B)
6. Localizar Spacer Set #1 (los espaciadores deben ser colocados detrás de las lengüetas de montaje durante la instalación).

*Continuará al ensamble del kit*

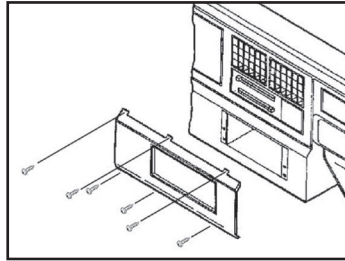

(Figura A)

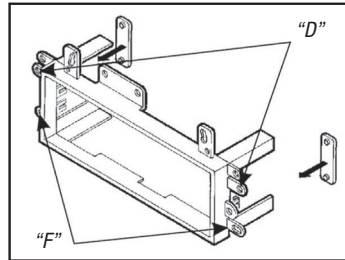

(Figura B)

### **Mercury Tracer (puerta trasera) 1989-1990**

1. Retire (3) tornillos Phillips de la parte superior del marco de terminación del tablero. (Figura A)
2. Retire el cenicero y (2) tornillos Phillips de la parte inferior del marco. (Figura A)
3. Retire (4) tornillos Phillips que sujetan la unidad central de fábrica y desconecte el cableado.
4. Corte y retire todos los soportes de montaje de la carcasa de la radio #1. (Figura B)

*Continuará al ensamble del kit*

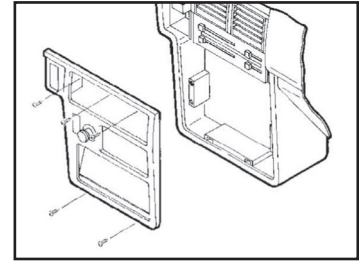

(Figura A)

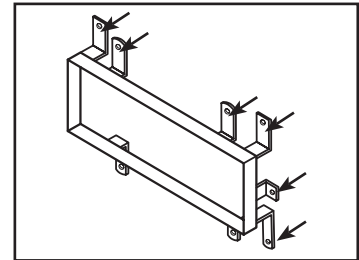

(Figura B)



## Ensamble del kit INST-FD-CR

**Aerostar 1985-1991, Bronco 1987-1991, Bronco II 1985-1988, Crown Victoria 1979-1990, Econoline 1975-1991, Escort 1985-1990, F-Series Pickup 1987-1991, LTD 1979-1984, Ranger 1985-1988, Taurus 1986-1989, Thunderbird 1985-1988, Continental 1985-1987, Mark VII 1984-1989, Town car 1984-1989, Cougar 1985-88, Grand Marquis 1979-1990, Lynx 1985-1990, Marquis 1979-1990, Sable 1986-1989, Tracer (puerta trasera) 1988-1990, All Jeeps**

1. Deslice la de la carcasa de la radio #2 y segura doblando el metal pestañas de bloqueo hacia abajo (coloque la puede ser añadido para una instalación semi-empotrada).
2. Deslice la unidad central de posventa en la caja hasta que esté sujeta. (Figura B)

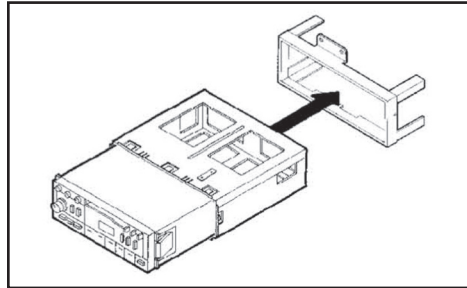

(Figura A)

**Bronco 1980-1986, F-Series Pickup 1980-1986, Festiva 1988-1993, Tempo 1985-1988, Topaz 1985-1988**

2. Deslice la jaula DIN en la caja y asegure doblando las lengüetas de fijación metálicos hacia abajo. (Figura A)
3. Deslice la unidad principal del mercado de accesorios en la jaula hasta que quede firme. (Figura A)

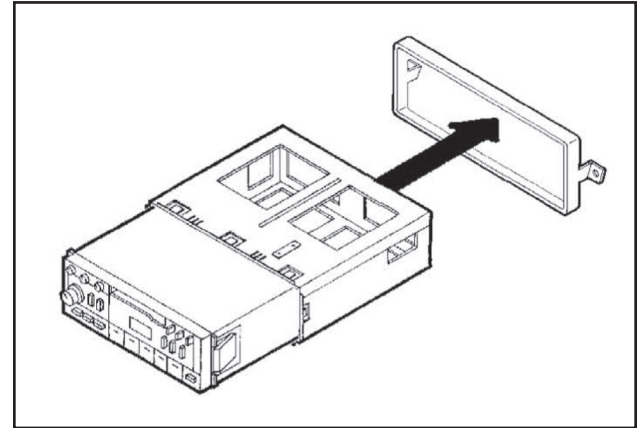

(Figura A)



### Sección 2

Ford/Jeep  
1974-2003

**99-6700**

#### CARACTERÍSTICAS DEL KIT

- Provisión de radio DIN

#### COMPONENTES DEL KIT

- A) Alojamiento del radio • B) Separadores de apoyo  
(Avenger/Sebring)

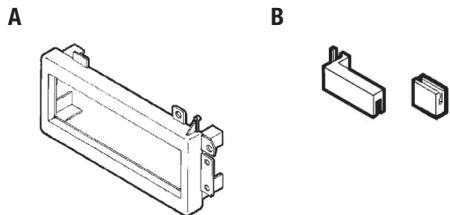

#### HERRAMIENTAS REQUERIDAS

- Destornillador Phillips • Herramientas de corte
- Herramienta toma de corriente

### Aplicaciones

#### Chrysler

Cirrus .....	1995-2000
Concorde .....	1993-1997
Cordoba .....	1975-1978
Cordoba .....	1979-1983
E-Class .....	1983-1984
Fifth Avenue .....	1990-1994
Imperial .....	1982-1983
Imperial .....	1990-1994
Laser .....	1984-1986
LeBaron .....	1976-1981
LeBaron .....	1982-1985
LeBaron .....	1986-1994
LeBaron GTS .....	1985-1994
LHS .....	1993-1997
Newport .....	1980-1981
New Yorker .....	1980-1981
New Yorker .....	1983-1987
New Yorker .....	1988-1996
Sebring .....	1995-2000
Sebring (conv) .....	1996-2000
Town & Country ..	1990-1995
Town & Country ..	1996-2000

#### Dodge

Aries .....	1981-1989
Aspen .....	1976-1980
Avenger .....	1995-2000
Caravan .....	1984-1990

Caravan .....	1991-1995
Caravan .....	1996-2000
Charger .....	1974-1978
Charger .....	1983-1987
Dakota .....	1987-1996
Dakota .....	1997-2000
Daytona .....	1984-1989
Daytona .....	1990-1993
Diplomat .....	1976-1989
Durango .....	1997-2000
Dynasty .....	1988-1993
Intrepid .....	1993-1997
Lancer .....	1985-1989
Magnum XE .....	1978-1979
Mirada .....	1980-1983
Neon .....	1994-1999
Omni .....	1978-1982
Pickup .....	1974-1980
Pickup .....	1981-1993
Ram .....	1994-2001
Ramcharger .....	1974-1980
Ramcharger .....	1981-1993
Rampage .....	1978-1982
Shadow .....	1987-1994
Spirit .....	1989-1995
SI Regis .....	1979-1981
Stratus .....	1995-2000
Van .....	1978-2003
024 .....	1978-1982

400 .....	1982-1983
600 .....	1983-1987

#### Eagle

Vision .....	1993-1997
--------------	-----------

#### Ford

Aerostar .....	1985-1991
Bronco II .....	1985-1988
Crown Victoria ..	1979-1990
LTD .....	1979-1990
Ranger (mini) .....	1985-1988
Thunderbird .....	1985-1988

#### Jeep

Cherokee .....	1997-2001
Grand Cherokee ..	1993-1995
Grand Cherokee ..	1996-1998
Wrangler .....	1997-2002

#### Lincoln

Continental .....	1985-1987
Mark VII .....	1984-1989

#### Mercury

Cougar .....	1985-1988
--------------	-----------

Grand Marquis .....	1979-1990
Marquis .....	1979-1990

#### Plymouth

Acclaim .....	1989-1995
Breeze .....	1996-2000
Caravelle .....	1985-1987
Fury .....	1975-1978
Gran Fury .....	1975-1985
Horizon .....	1978-1982
Neon .....	1994-1999
Reliant .....	1981-1989
Scamp .....	1983-1984
Sundance .....	1987-1994
TC3 .....	1978-1982
Trailduster .....	1974-1980
Trailduster .....	1981
Turismo .....	1983-1987
Van .....	1978-2003
Volare .....	1976-1980
Voyager .....	1984-1990
Voyager .....	1991-1995
Voyager .....	1996-2000

### Índice

Desmontaje del tablero ..... 15-28

#### Ensamble del kit

– Provisión de radio DIN..... 28

– Ensamble del kit final ..... 29-30

**Chrysler Cirrus/Dodge Stratus 1995-2000, Plymouth Breeze 1996-2000**

1. Utilizando un destornillador de hoja plana, levante haciendo palanca en los bordes del marco de terminación del radio. Desenganche el marco y retírelo. (Figura A)
2. Retire (2) tornillos de cabeza hexagonal de 3/8 in que sujetan la unidad central de fábrica y desconecte el cableado. (Figura B)
3. Corte y retire todas las lengüetas de montaje del alojamiento del radio, SALVO las lengüetas sombreadas. (Figura B)

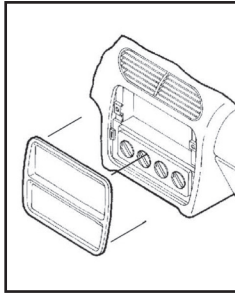

(Figura A)

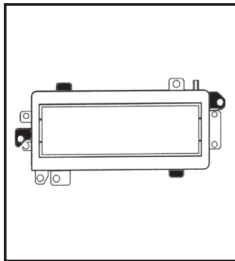

(Figura B)

*Continuará al  
ensamble del kit*

**Chrysler Concorde/LHS/  
Dodge Intrepid/Eagle Vision  
1993-1997**

1. Desenganche el marco de terminación del radio y retírelo. (Figura A)
2. Retire (2) tornillos de cabeza hexagonal de 3/8 in que sujetan la unidad central de fábrica y desconecte el cableado.
3. Corte y retire todas las lengüetas de montaje del alojamiento del radio, SALVO las lengüetas sombreadas. (Figura B)

*Continuará al  
ensamble del kit*

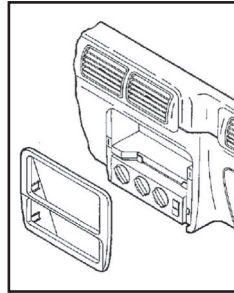

(Figura A)

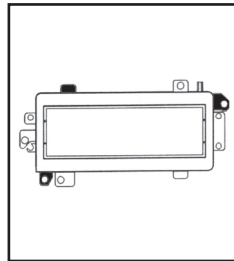

(Figura B)

**Chrysler Cordoba/Plymouth Fury 1975-1978, Dodge Charger 1974-1978/Magnum XE 1978-1979**

1. Retire (4) tornillos Phillips del borde inferior del marco de terminación del radio.
2. Retire (2) tornillos Phillips que se encuentran arriba de la abertura del radio. (Figura A)
3. Desatornille el anillo de retención que sujeta el control remoto del espejo y retire el marco.
4. Retire (2) tornillos de cabeza hexagonal de 3/8 in que sujetan la unidad central de fábrica y desconecte el cableado.
5. Corte y retire todas las lengüetas de montaje del alojamiento del radio, SALVO las lengüetas sombreadas. (Figura B)

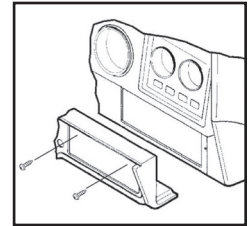

(Figura A)

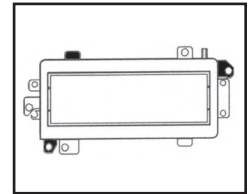

(Figura B)

*Continuará al ensamble del kit*

**Chrysler Cordoba 1979-1985/Imperial  
1982-1983, Newport/New Yorker 1980-1981,  
Dodge Mirada 1980-1983/  
St. Regis 1979-1981**

1. Retire (2) tornillos Phillips del borde inferior del marco de terminación del radio. (Figura A)
2. Retire (2) tornillos Phillips que se encuentran arriba de la abertura del radio.
3. Desatornille el anillo de retención que sujeta el control remoto del espejo y retire el marco.
4. Retire (2) tornillos de cabeza hexagonal de 3/8 in que sujetan la unidad central de fábrica y desconecte el cableado.
5. Corte y retire todas las lengüetas de montaje del alojamiento del radio, SALVO las lengüetas sombreadas. (Figura B)

*Continuará al ensamble del kit*

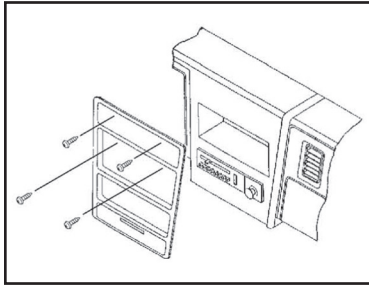

(Figura A)

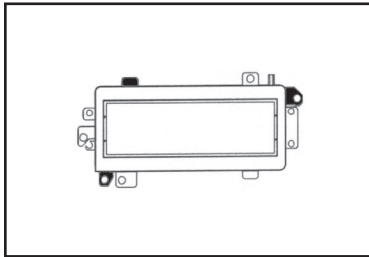

(Figura B)

**Chrysler E-Class 1983-1984/LeBaron  
1982-1985/New Yorker 1983-1987, Dodge  
Aries 1981-1989/400 1982-1983/600  
1983-1987, Plymouth Caravelle 1985-1987/  
Reliant 1981-1989**

1. Retire (3) tornillos Phillips del borde superior del marco de terminación del tablero.
2. Retire (3) tornillos Phillips del borde inferior del marco de terminación del tablero.
3. Desenganche el marco y desconecte el cableado. (Figura A)
4. Retire (2) tornillos de cabeza hexagonal de 3/8 in que sujetan la unidad central de fábrica y desconecte el cableado.
5. Corte y retire todas las lengüetas de montaje del alojamiento del radio, SALVO las lengüetas sombreadas. (Figura B)

*Continuará al ensamble del kit*

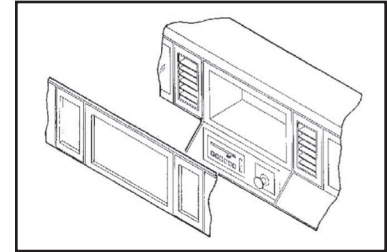

(Figura A)

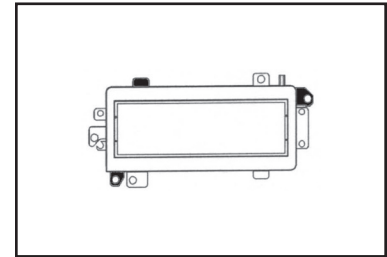

(Figura B)



## Desmontaje del tablero INST-FD-CR

### Chrysler Fifth Avenue/ Imperial 1990-1994, New Yorker 1988-1996, Dodge Dynasty 1988-1993

1. Retire (2) tornillos Phillips que se encuentran arriba de la abertura del radio. (Figura A)
2. Retire (2) tornillos Phillips que se encuentran arriba de los controles de clima. (Figura A)
3. Desenganche el marco de terminación del tablero y retírelo.
4. Retire (2) tornillos de cabeza hexagonal de 3/8 in que sujetan la unidad central de fábrica y desconecte el cableado. (Figura A)
5. Corte y retire todas las lengüetas de montaje del alojamiento del radio, SALVO las lengüetas sombreadas. (Figura B)

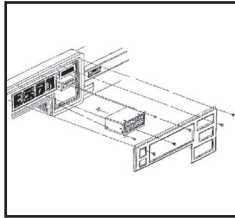

(Figura A)

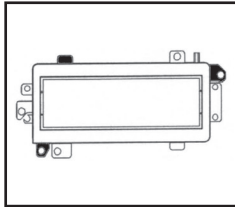

(Figura B)

Continuará al ensamble del kit

### Chrysler Laser 1984-1986 Dodge Daytona 1984-1989

1. Retire (2) tornillos Phillips de la base del marco de terminación del tablero.
2. Jale el borde inferior del marco hacia afuera y retírelo. (Figura A)
3. Retire (2) tornillos de cabeza hexagonal de 3/8 in que sujetan la unidad central de fábrica y desconecte el cableado.
4. Corte y retire todas las lengüetas de montaje del alojamiento del radio, SALVO las lengüetas sombreadas. (Figura B)

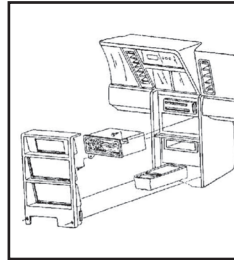

(Figura A)

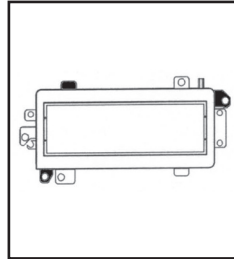

(Figura B)

Continuará al  
ensamble del kit

### Chrysler LeBaron 1986-1994

1. Retire (1) tornillo Phillips de la esquina inferior del marco de terminación del tablero.
2. Desenganche el marco y retírelo.
3. Retire (2) tornillos Phillips del panel de la consola derecha y retire el panel. (Figura A)
4. Retire (2) tornillos de cabeza hexagonal que sujetan la unidad central de fábrica y desconecte el cableado.
5. Corte y retire todas las lengüetas de montaje del alojamiento del radio, SALVO las lengüetas sombreadas. (Figura B)

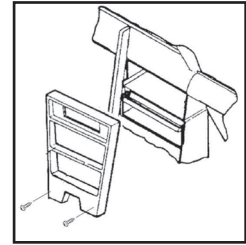

(Figura A)

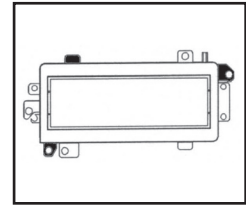

(Figura B)

Continuará al ensamble del kit

**Chrysler LeBaron GT5 1985-1994,  
Dodge Lancer 1985-1989**

1. Retire (5) tornillos de cabeza Torx de la parte superior del marco de terminación del tablero.
2. Retire (2) tornillos de cabeza Torx que se encuentran debajo de la abertura del radio.
3. Retire (1) tornillo de cabeza Torx de la esquina superior izquierda de la abertura del radio.
4. Retire (4) tornillos de cabeza Torx del área inferior izquierda del marco de terminación del tablero. (Figura A)
5. Desenganche el marco y retírelo. Retire (2) tornillos de cabeza hexagonal de 3/8 in que sujetan la unidad central de fábrica y desconecte el cableado.
6. Corte y retire todas las lengüetas de montaje del alojamiento del radio, SALVO las lengüetas sombreadas. (Figura B)  
*Continuará al ensamble del kit*

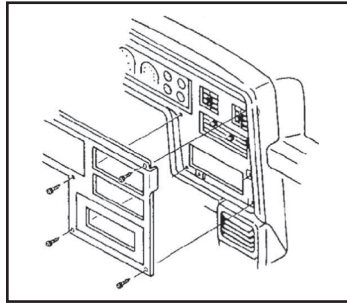
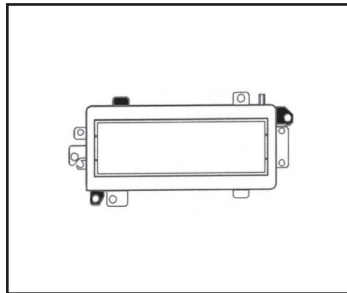
*(Figura A)**(Figura B)***Chrysler LeBaron 1976-1981,  
Dodge Diplomat 1976-1989/Aspen  
1976-1980, Plymouth Gran Fury  
1975-1985/Volare 1976-1980**

1. Retire (4) tornillos Phillips de la parte superior del bisel ajuste de la rociada y luego retire (4) de la parte inferior del bisel ajuste de la rociada. (Figura A)
2. Retire (2) tornillos de cabeza hexagonal de 3/8 in que sujetan la unidad central de fábrica y desconecte el cableado.
3. Corte y retire todas las lengüetas de montaje del alojamiento del radio, SALVO las lengüetas sombreadas. (Figura B)

*Continuará al ensamble del kit*

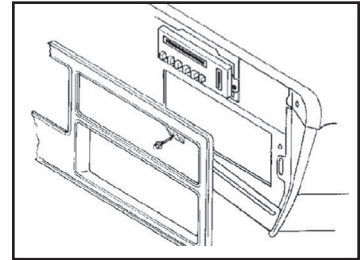
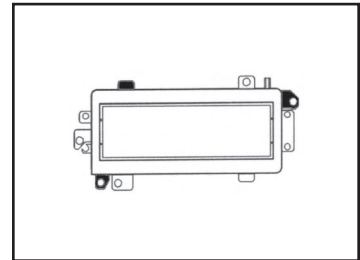
*(Figura A)**(Figura B)*

**Chrysler Sebring (convertible)  
1996-2000**

1. Desenganche el marco de terminación del radio y retírelo. (Figura A)
2. Retire (2) tornillos de cabeza hexagonal de 3/8 in que sujetan la unidad central de fábrica y desconecte el cableado.
3. Corte y retire todas las lengüetas de montaje del alojamiento del radio, SALVO las lengüetas sombreadas. (Figura B)

*Continuará al  
ensamble del kit*

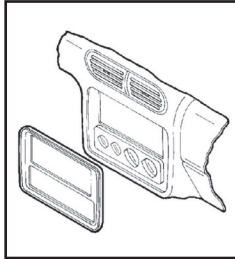

(Figura A)

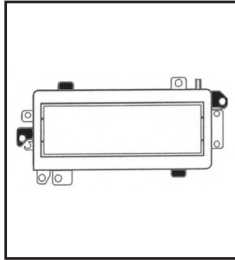

(Figura B)

**Dodge Sebring/Avenger  
1995-2000**

1. Desenganche el marco de terminación del radio y retírelo. (Figura A)
2. Retire (2) tornillos Phillips #10 que sujetan la unidad central de fábrica y desconecte el cableado.
3. Corte y retire todas las lengüetas de montaje del alojamiento del radio, SALVO las lengüetas sombreadas. (Figura B)

*Continuará al  
ensamble del kit*

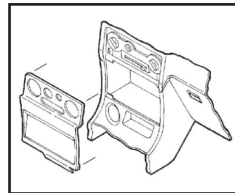

(Figura A)

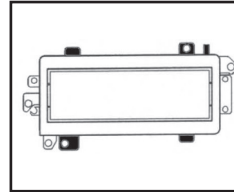

(Figura B)

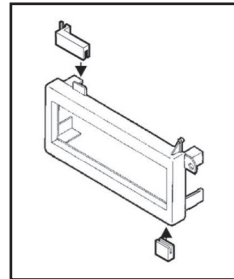

(Figura C)

**Dodge Caravan/Plymouth  
Voyager 1991-1995**

1. Retire el encendedor.
2. Utilizando una herramienta para retirar paneles, levante haciendo palanca en el marco de terminación del tablero y retírelo. (Figura A)
3. Retire (2) tornillos de 3/8 in que sujetan la unidad central de fábrica y desconecte el cableado.
4. Corte y retire todas las lengüetas de montaje del alojamiento del radio, SALVO las lengüetas sombreadas. (Figura B)

*Continuará al  
ensamble del kit*

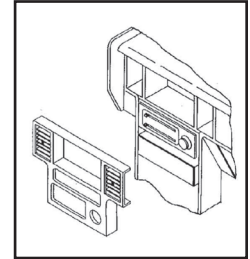

(Figura A)

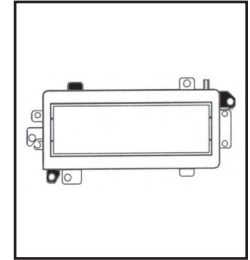

(Figura B)

## Chrysler Town & Country 1990-1995, Dodge Caravan 1984-1990, Plymouth Voyager 1984-1990

1. Coloque la mano detrás del cenicero y suelte la lengüeta trasera del alojamiento del cenicero.
2. Retire (2) tornillos del borde inferior del marco de terminación del tablero. Retire (3) tornillos del borde superior del marco de terminación del tablero. (Figura A)
3. Quite a presión el borde izquierdo del marco y retírelo.
4. Retire (2) tornillos de cabeza hexagonal de 3/8 in que sujetan la unidad central de fábrica y desconecte el cableado.
5. Corte y retire todas las lengüetas de montaje del alojamiento del radio, SALVO las lengüetas sombreadas. (Figura B)

*Continuará al ensamble del kit*

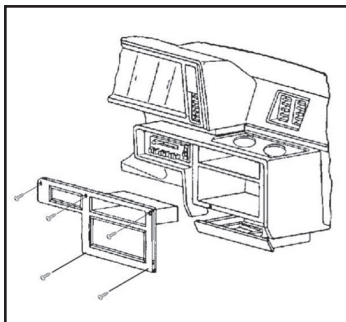

(Figura A)

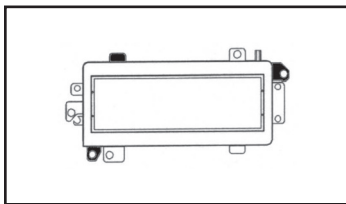

(Figura B)

## Dodge Caravan/Chrysler Town & Country/Plymouth Voyager 1996-2000

1. Saque el cenicero hacia adelante. Quite la pieza de plástico situada debajo de la moldura bisel ajuste de radio y quitar (2) tornillos Phillips expuestos. (Figura A)
2. Retire (2) tornillos Phillips que se encuentran arriba de la abertura del radio.
3. Desenganche el marco de terminación del tablero, desconecte el cableado del control de clima y retire el marco.
4. Retire (2) tornillos de cabeza hexagonal de 3/8 in que sujetan la unidad central de fábrica y desconecte el cableado.
5. Corte y retire todas las lengüetas de montaje del alojamiento del radio, SALVO las lengüetas sombreadas. (Figura B)

*Continuará al ensamble del kit*

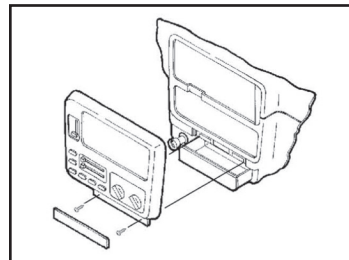

(Figura A)

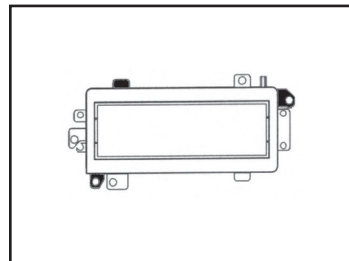

(Figura B)

**Dodge Charger/Plymouth  
Turismo 1983-1987**

1. Desenganche el marco de terminación del radio y retírelo.
2. Retire (2) tornillos de cabeza hexagonal de 3/8 in que sujetan la unidad central de fábrica y desconecte el cableado.
3. Corte y retire todas las lengüetas de montaje del alojamiento del radio, SALVO las lengüetas sombreadas. (Figura B)

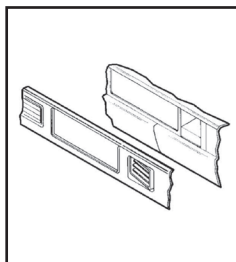

(Figura A)

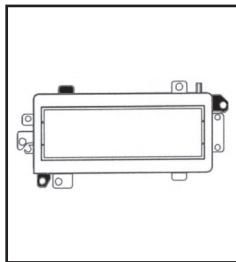

(Figura B)

*Continuará al  
ensamble del kit*

**Dodge Dakota  
1987-1996**

1. Retire (8) tornillos de cabeza Torx del marco de terminación del tablero.
2. Retire (2) tornillos Phillips del marco de la columna de la dirección inferior y retírelo.
3. Retire (1) tornillo Phillips de cada lado de la columna de la dirección.
4. Desenganche el marco de terminación del tablero y retírelo. (Figura A)
5. Retire (2) tornillos Phillips que sujetan la unidad central de fábrica y desconecte el cableado.
6. Corte y retire todas las lengüetas de montaje del alojamiento del radio, SALVO las lengüetas sombreadas. (Figura B)

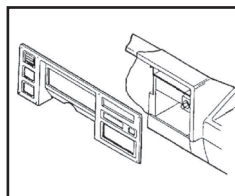

(Figura A)

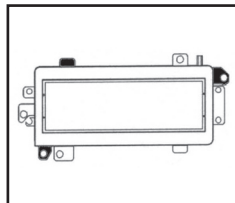

(Figura B)

*Continuará al ensamble del kit*

**Dodge Dakota  
1997-2000**

1. Desenganche todo el marco de terminación del tablero. (Figura A)
2. Retire (2) tornillos de cabeza hexagonal de 3/8 in que sujetan la unidad central de fábrica y desconecte el cableado.
3. Corte y retire todas las lengüetas de montaje del alojamiento del radio, SALVO las lengüetas sombreadas. (Figura B)

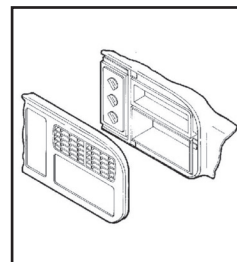

(Figura A)

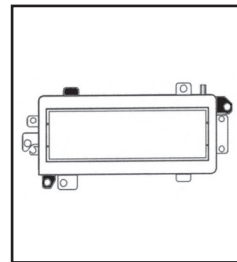

(Figura B)

*Continuará al  
ensamble del kit*

**Dodge Daytona  
1990-1993**

1. Jale el marco de terminación del tablero hacia afuera y retírelo. (Figura A)
2. Retire (2) tornillos de cada lado de la consola inferior (esto hará que sea más fácil retirar el radio).

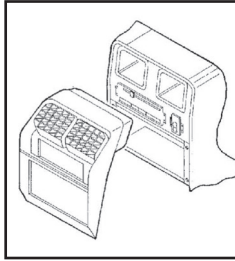
*(Figura A)*

3. Retire (2) tornillos que sujetan la unidad central de fábrica y desconecte el cableado.
4. Corte y retire todas las lengüetas de montaje del alojamiento del radio, SALVO las lengüetas sombreadas. (Figura B)

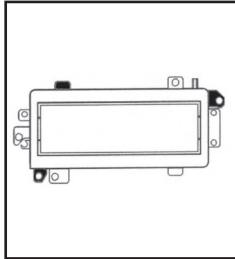
*(Figura B)*

*Continuará al  
ensamble del kit*

**Dodge Durango  
1997-2000**

1. Desenganche todo el marco de terminación del tablero. (Figura A)
2. Retire (2) tornillos de cabeza hexagonal de 3/8 in que sujetan la unidad central de fábrica y desconecte el cableado.
3. Corte y retire todas las lengüetas de montaje del alojamiento del radio, SALVO las lengüetas sombreadas. (Figura B)

*Continuará al  
ensamble del kit*

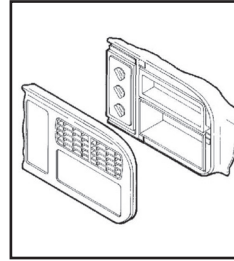
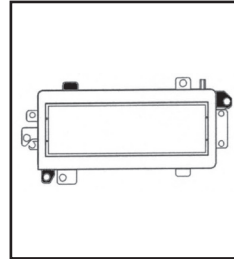
*(Figura A)**(Figura B)***Dodge Neon/Plymouth  
Neon 1994-1999**

1. Retire el cenicero. Desenganche el marco de terminación del radio y retírelo. (Figura A)
2. Retire (2) tornillos de cabeza hexagonal de 3/8 in que sujetan la unidad central de fábrica y desconecte el cableado.
3. Corte y retire todas las lengüetas de montaje del alojamiento del radio, SALVO las lengüetas sombreadas. (Figura B)

*Continuará al  
ensamble del kit*

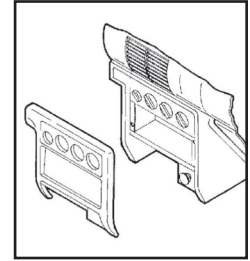
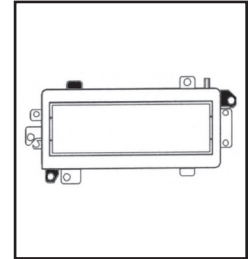
*(Figura A)**(Figura B)*

**Dodge Omni/024/Rampage  
1978-1982, Plymouth  
Horizon/TC3 1978-1982/  
Scamp 1983-1984**

1. Retire (7) tornillos Phillips del marco de terminación del tablero y retire el marco. (Figura A)
2. Retire (2) tornillos de cabeza hexagonal de 3/8 in que sujetan la unidad central de fábrica y desconecte el cableado.
3. Corte y retire todas las lengüetas de montaje del alojamiento del radio, SALVO las lengüetas sombreadas. (Figura B)

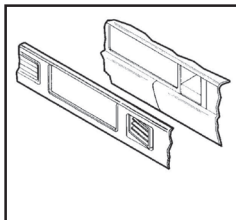
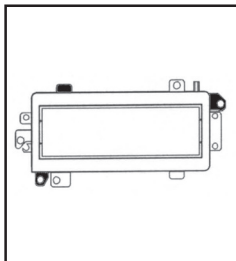
*(Figura A)*

*(Figura B)*

*Continuará al  
ensamble del kit*

**Dodge Pickup/Ramcharger/  
Plymouth Trailduster  
1974-1980**

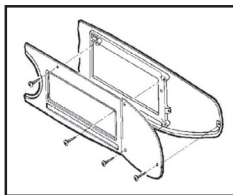
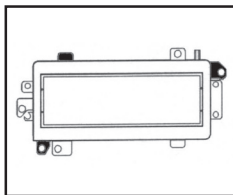
1. Remove (4) Phillips screws from the top edge of the dash trim bezel. (Figura A)
2. Remove (7) Phillips screws from the face of the dash trim bezel.
3. Remove (3) Phillips screws under the dash trim bezel.
4. Unclip the bezel and remove. Remove (2) 3/8" hex-head screws securing the factory radio and disconnect the wiring.
5. Cut and remove all mounting tabs on the radio housing EXCEPT the shaded tabs. (Figura B)

*(Figura A)*

*(Figura B)*

*Continuará al ensamble del kit*

**Dodge Pickup/Ramcharger  
1981-1993, Plymouth  
Trailduster 1981**

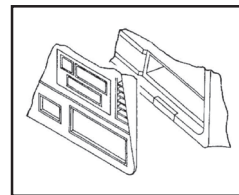
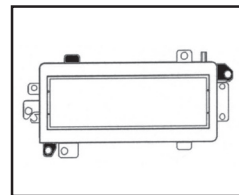
1. Retire (5) tornillos Phillips del borde del marco de terminación del tablero.
2. Retire (1) tornillo Phillips que se encuentra arriba de la abertura del radio.
3. Levante haciendo palanca en el borde inferior del marco y retírelo. (Figura A)
4. Retire (2) tornillos de cabeza hexagonal de 3/8 in que sujetan la unidad central de fábrica y desconecte el cableado.
5. Corte y retire todas las lengüetas de montaje del alojamiento del radio, SALVO las lengüetas sombreadas. (Figura B)

*(Figura A)*

*(Figura B)*

*Continuará al ensamble del kit*

### Dodge Ram 1994-2001

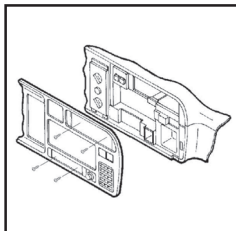
1. Remove the ashtray. Remove (2) Phillips screws exposed in the ashtray cavity and remove the ashtray bracket. (Figura A)
2. Remove the cupholder. Remove (2) Phillips screws exposed in the cup holder cavity and remove the cupholder bracket. (Figura A)
3. Unclip the dash trim bezel, pull the bezel over the steering column and remove.
4. Remove (2) 3/8" hex-head screws securing the factory radio and disconnect the wiring.
5. Cut and remove all mounting tabs on the radio housing EXCEPT the shaded tabs. (Figura B)



(Figura A)

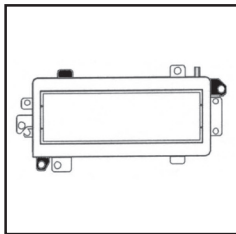

(Figura B)

*Continuará al ensamble del kit*

### Dodge Shadow/Plymouth Sundance 1987-1994

1. Retire el cenicero. Desenganche el marco de terminación del tablero y retírelo. (Figura A)
2. Retire (1) tornillo Phillips de la terminación de la consola lateral y retírela.
3. Retire (2) tornillos de cabeza hexagonal de 3/8 in que sujetan la unidad central de fábrica y desconecte el cableado.
4. Corte y retire todas las lengüetas de montaje del alojamiento del radio, SALVO las lengüetas sombreadas. (Figura B)

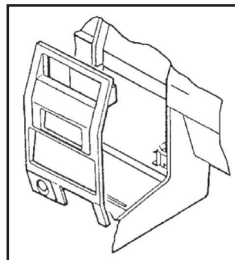

(Figura A)

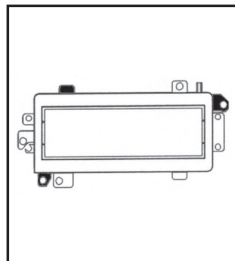

(Figura B)

*Continuará al ensamble del kit*

### Dodge Spirit/Plymouth Acclaim 1989-1995

1. Unclip the dash trim bezel and remove. Remove the screws securing the side console trim pieces. (Figura A)
2. Pull the right trim piece out and remove (1) hex-head bolt exposed.
3. Remove (1) hex-head bolt securing the bottom-left corner of the factory radio and disconnect the wiring.
4. Cut and remove all mounting tabs on the radio housing EXCEPT the shaded tabs. (Figura B)

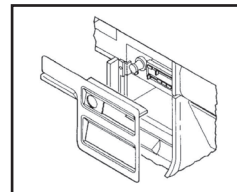

(Figura A)

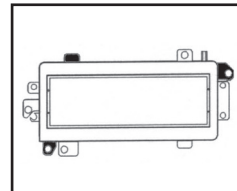

(Figura B)

*Continuará al ensamble del kit*



## Dodge Van/Plymouth Van 1978-2003

1. Open the glove box and remove (2) Phillips screws exposed.
2. Remove (5) Phillips screws from the bottom of the dash trim bezel.
3. Unclip the top edge of the bezel and remove.
4. Remove (2) 3/8" hex-head screws securing the factory radio and disconnect the wiring.
5. Cut and remove all mounting tabs on the radio housing EXCEPT the shaded tabs.

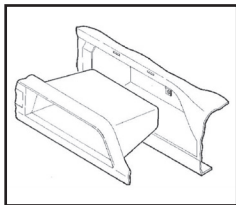

(Figura A)

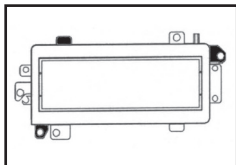

(Figura B)

### For 1998-2003 Dodge Van

1. Unclip and remove entire panel surrounding radio and instrument cluster.
2. Remove (2) 3/8" hex-head screws securing the factory radio and disconnect the wiring.

*Continuará al ensamble del kit*

## Ford Aerostar 1985-1991

1. Retire (2) tornillos Phillips de la base del panel del tablero. (Figura A)
2. Levante haciendo palanca en las (2) lengüetas que se encuentran en la parte superior del marco de terminación del radio y retire el radio. (Figura A)
3. Retire (4) tornillos que sujetan la unidad central de fábrica y desconecte el cableado.
4. Corte y retire todas las lengüetas de montaje del alojamiento del radio, SALVO las lengüetas sombreadas. (Figura B)

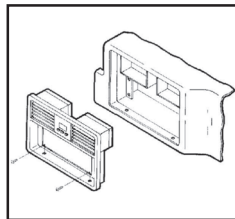

(Figura A)

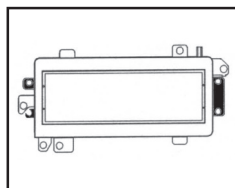

(Figura B)

*Continuará al ensamble del kit*

## Ford Bronco II/Ranger (mini) 1985-1988

1. Remove (4) Phillips screws from the top edge of the dash trim bezel. (Figura A)
2. Remove the light switch knob, cigarette lighter and ashtray.
3. Unsnap the molding under the dash trim bezel and remove (4) screws exposed. (Figura A)
4. Remove (4) screws securing the factory radio and disconnect the wiring.
5. Cut and remove all mounting tabs on the radio housing EXCEPT the shaded tabs. (Figura B)

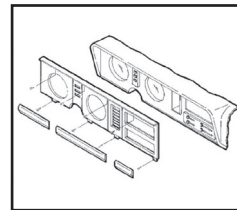

(Figura A)

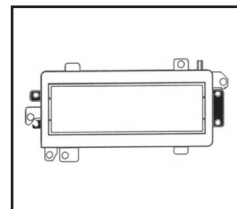

(Figura B)

*Continuará al ensamble del kit*

## Desmontaje del tablero INST-FD-CR

### Ford Crown Victoria/ LTD 1979-1990, Mercury Grand Marquis/Marquis 1979-1990

1. Abra el cenicero y retire (2) tornillos Phillips expuestos. (Figura A)
2. Retire el bisel ajuste de la rociada.
3. Retire (4) tornillos que sujetan la unidad central de fábrica y desconecte el cableado.
4. Corte y retire todas las lengüetas de montaje del alojamiento del radio, SALVO las lengüetas sombreadas. (Figura B)

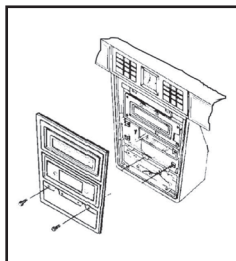

(Figura A)

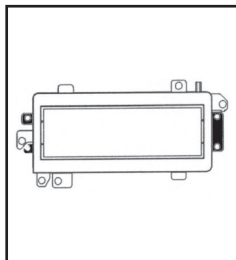

(Figura B)

Continuará al  
ensamble del kit

### Ford Thunderbird/Mercury Cougar 1985-1988

1. Retire (2) tornillos de la parte superior del marco de terminación del tablero. (Figura A)
2. Abra el cenicero y retire (2) tornillos expuestos en el hueco del cenicero. (Figura A)
3. Retire el bisel ajuste de la rociada. Retire (4) tornillos que sujetan la unidad central de fábrica y desconecte el cableado.
4. Corte y retire todas las lengüetas de montaje del alojamiento del radio, SALVO las lengüetas sombreadas. (Figura B)

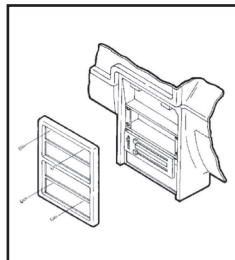

(Figura A)

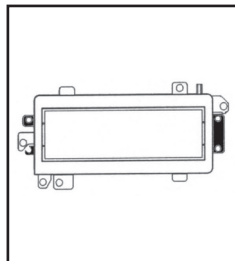

(Figura B)

Continuará al  
ensamble del kit

### Jeep Cherokee 1997-2001

1. Desenganche el bisel ajuste de la rociada. (Figura A)
2. Retire (2) #10 tornillos de cabeza hexagonal que sujetan la unidad central de fábrica y desconecte el cableado.
3. Corte y retire todas las lengüetas de montaje del alojamiento del radio, SALVO las lengüetas sombreadas. (Figura B)

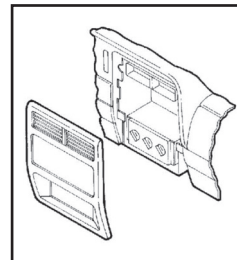

(Figura A)

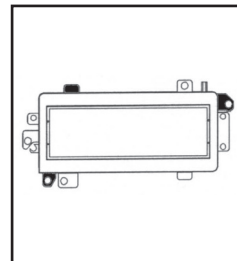

(Figura B)

Continuará al  
ensamble del kit

**Jeep Grand Cherokee  
1993-1995**

1. Retire (2) tornillos Phillips de la parte inferior del marco de terminación del tablero. (Figura A)

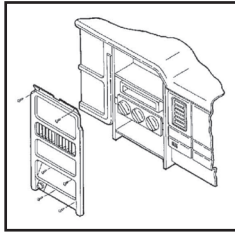
*(Figura A)*

2. Retire (2) tornillos Phillips que se encuentran arriba de la abertura del radio. (Figura A)

3. Retire (2) tornillos Phillips que se encuentran a la izquierda de la columna de la dirección. (Figura A)

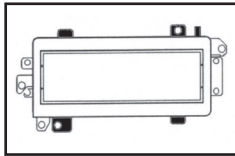
*(Figura B)*

4. Retire (1) tornillo Phillips que se encuentra a la derecha de la columna de la dirección. Desenganche el marco de terminación del tablero y desconecte el cableado.

5. Corte y retire todas las lengüetas de montaje del alojamiento del radio, SALVO las lengüetas sombreadas. (Figura B)

*Continuará al ensamble del kit*

**Jeep Grand Cherokee  
1996-1998**

1. Quite a presión el panel de terminación del clima/control del limpiaparabrisas y retírelo.

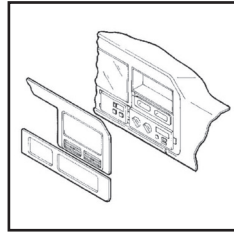
*(Figura A)*

2. Retire (5) tornillos Phillips de la parte superior del marco de terminación del radio/grupo de instrumentos.

3. Retire (4) tornillos Phillips de la parte inferior del marco de terminación del radio/grupo de instrumentos.

4. Levante haciendo palanca en el borde inferior del marco y retírelo. (Figura A)

5. Retire (2) tornillos de cabeza hexagonal de 3/8 in que sujetan la unidad central de fábrica y desconecte el cableado.

6. Corte y retire todas las lengüetas de montaje del alojamiento del radio, SALVO las lengüetas sombreadas. (Figura B)

*Continuará al ensamble del kit*

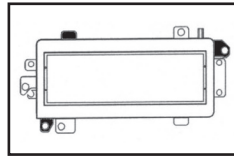
*(Figura B)***Jeep Wrangler  
1997-2002**

1. Retire el cenicero y (1) tornillo Phillips expuesto en el hueco del cenicero. (Figura A)

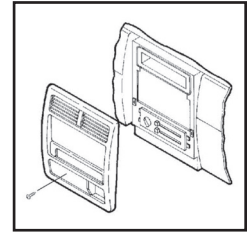
*(Figura A)*

2. Levante haciendo palanca en la cubierta superior del panel de instrumentos y retire (2) tornillos Phillips expuestos.

3. Levante haciendo palanca en el borde inferior del marco de terminación del tablero y retírelo.

4. Retire (2) tornillos de cabeza hexagonal de 3/8 in que sujetan la unidad central de fábrica y desconecte el cableado.

5. Corte y retire todas las lengüetas de montaje del alojamiento del radio, SALVO las lengüetas sombreadas. (Figura B)

*Continuará al ensamble del kit*

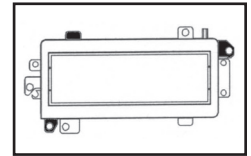
*(Figura B)*

### Lincoln Continental 1985-1987

1. Retire (2) tornillos Phillips #8, encuentran debajo de la abertura del radio. (Figura A)
2. Abra el cenicero y retire (2) #8 tornillos Phillips (NO es necesario retirar el tornillo central). (Figura A)

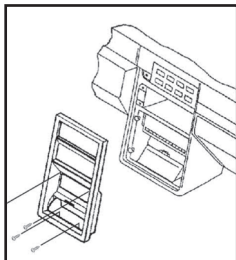

(Figura A)

3. Desenganche el marco de terminación del tablero y retírelo.
4. Retire (4) tornillos de cabeza hexagonal que sujetan la unidad central de fábrica y desconecte el cableado.

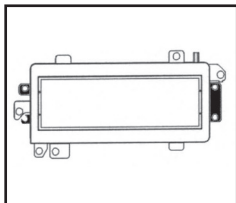

(Figura B)

5. Corte y retire todas las lengüetas de montaje del alojamiento del radio, SALVO las lengüetas sombreadas. (Figura B)

Continuará al ensamble del kit

### Lincoln Mark VII 1984-1989

1. Levante haciendo palanca en el marco de terminación del tablero y retírelo. (Figura A)
2. Retire (4) tornillos de cabeza hexagonal de 5mm que sujetan la unidad central de fábrica y desconecte el cableado.

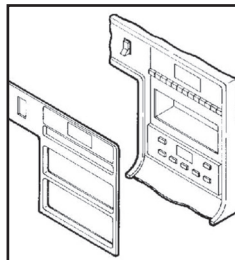

(Figura A)

3. Corte y retire todas las lengüetas de montaje del alojamiento del radio, SALVO las lengüetas sombreadas. (Figura B)

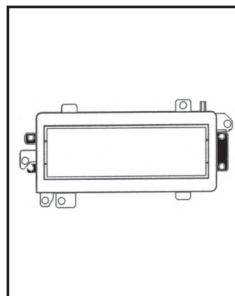

(Figura B)

Continuará al ensamble del kit

### Provisión de radio DIN

1. Deslice la jaula DIN en la carcasa de la radio y asegurar doblando las lengüetas de fijación metálicos hacia abajo.
2. Deslice la unidad principal del mercado de accesorios en la jaula hasta que quede firme. (Figura A)

Continue to final kit assembly

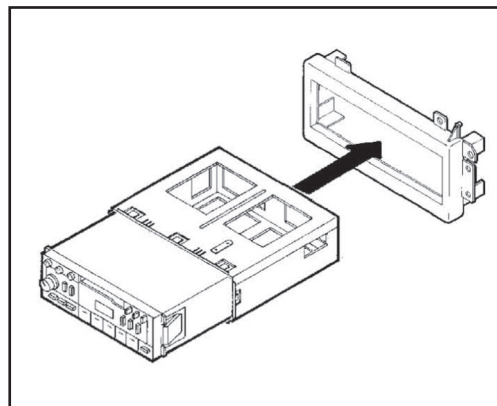

(Figura A)



## Ensamble del kit INST-FD-CR

### Ensamble del kit final

1. Ubique el arnés del cableado de fábrica en el tablero. Metra recomienda usar el adaptador de acoplamiento adecuado de Metra o AXCESS. Pruebe la unidad para verificar que funcione correctamente.

#### Ford/Lincoln/Mercury

2. Monte el conjunto de unidad central/kit en el sub tablero con (4) tornillos que retiró previamente. (Figura A)
3. Vuelva a montar el tablero en forma inversa al desmontaje.

#### Chrysler/Dodge/Plymouth/Eagle/Jeep

*(excluding Grand Cherokee 1993-1995, Cirrus, Stratus, Breeze, Sebring, Avenger)*

2. Monte el conjunto de unidad central/kit en el sub tablero con (2) tornillos de cabeza hexagonal de 3/8 in que retiró previamente. (Figura B)
3. Vuelva a montar el tablero en forma inversa al desmontaje.

#### Jeep Grand Cherokee 1993-1995

2. Monte el conjunto de unidad central/kit en el sub tablero con (2) tornillos que retiró previamente. (Figura C)
3. Vuelva a montar el tablero en forma inversa al desmontaje.

*Continúa en la página*

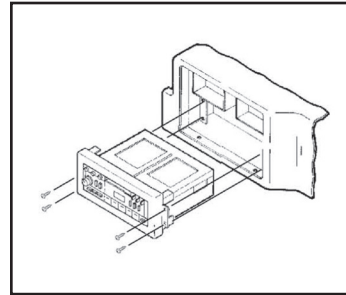

(Figura A)

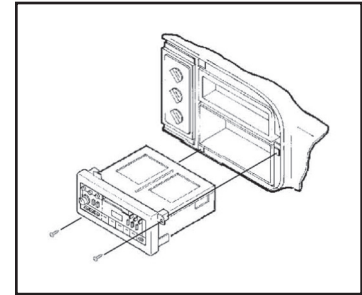

(Figura B)

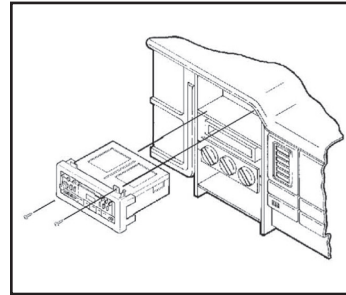

(Figura C)

## Ensamble del kit final

### Chrysler Cirrus, Dodge Stratus, Plymouth Breeze

2. Monte el conjunto de unidad central/kit en el sub tablero con (2) tornillos que retiró previamente. (Figura D)
3. Vuelva a montar el tablero en forma inversa al desmontaje.

### Chrysler Sebring, Dodge Avenger

2. Retire el tornillo superior izquierdo del alojamiento del tablero de metal.
3. Monte el conjunto de unidad central/kit en el sub tablero con (2) tornillos que retiró previamente. (Figura E)
4. Vuelva a colocar el tornillo del alojamiento de metal a través del espaciador de soporte superior. (Figura E)
5. Vuelva a montar el tablero en forma inversa al desmontaje.

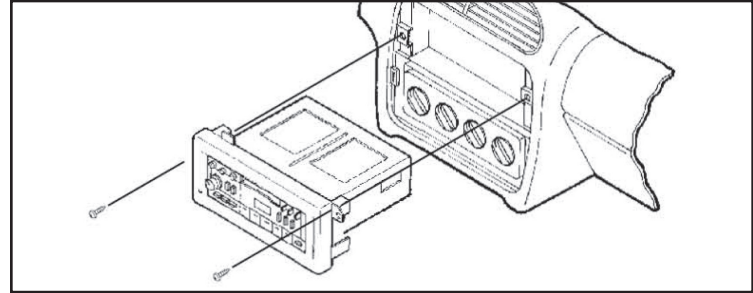

(Figura D)

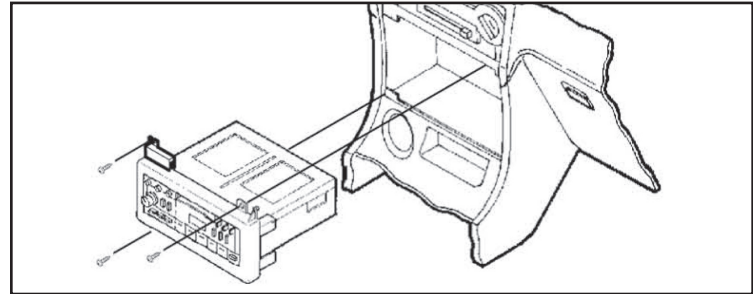

(Figura E)





## Instrucciones de instalación para la pieza INST-FD-CR



### IMPORTANTE

Si tiene dificultades con la instalación de este producto, llame a nuestra línea de soporte técnico al **1-800-253-TECH**. Antes de hacerlo, revise las instrucciones por segunda vez y asegúrese de que la instalación se haya realizado exactamente como se indica en las instrucciones. Por favor tenga el vehículo desarmado y listo para ejecutar los pasos de resolución de problemas antes de llamar.



#### EL CONOCIMIENTO ES PODER

Mejore sus habilidades de instalación y fabricación inscribiéndose en la escuela de dispositivos electrónicos móviles más reconocida y respetada de nuestra industria. Regístrese en [www.installerinstitute.com](http://www.installerinstitute.com) o llame al 800-354-6782 para obtener más información y avance hacia un futuro mejor.



Metra recomienda técnicos con certificación del Programa de Certificación en Electrónica Móvil (Mobile Electronics Certification Program, MECP).

REV 10/19/2016 INST-FD-CR



Axxess Integrate

[axsessinterfaces.com](http://axsessinterfaces.com) • [metraonline.com](http://metraonline.com)

© COPYRIGHT 2016 METRA ELECTRONICS CORPORATION