



INSTALLATION INSTRUCTIONS FOR PART 99-9600

APPLICATIONS

Harley-Davidson 1998-2013

(FL models with fairings)

99-9600



KIT FEATURES

- ISO DIN radio provision
- Pre-wired ASWC-1 harness included (*Axxess ASWC-1 is sold separately, for retention of handlebar controls*)

KIT COMPONENTS

- A) Radio housing • B) Rubber gasket • C) (4) 1/2" long button-head cap screws
- D) Harness (not shown)

A

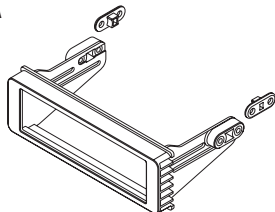

B

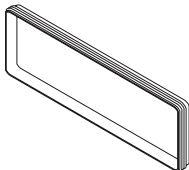

C

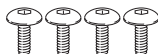

WIRING & ANTENNA CONNECTIONS (sold separately)

- Wiring Harness: • Included
Antenna Adapter: • Not required

Table of Contents

Fairing Disassembly

- Harley-Davidson FLH (*batwing fairing*)
1998-2013 2-3
- Harley-Davidson Roadglide (*sharknose fairing*)
1998-2013 4-5

Kit Assembly

- ISO DIN radio provision..... 6
- Wiring Instructions 7

TOOLS REQUIRED

- Panel removal tool • Phillips screwdriver
- Socket wrench (T-25, T-27, 6mm or 3/16 hex)

CAUTION: Metra recommends disconnecting the negative battery terminal before beginning any installation. All accessories, switches, and especially air bag indicator lights must be plugged in before reconnecting the battery or cycling the ignition.

NOTE: Refer to the instructions included with the aftermarket radio.

Fairing Disassembly

FLH/Batwing models:

1. Cover the front fender.
2. Remove (2) T-27 Torx bolts from inner fairing (under mirrors) (Figure A, step 2)
3. Remove (2) T-27 Torx bolts from outer edges of inner fairing near the fork tubes (facing forward) (Figure A, step 3)
4. Remove (3) T-27 Torx bolts from bottom edge of windshield. (Figure A, step 4)

NOTE: Windshield and fairing will be loose once these screws are removed. Use extreme caution not to damage fairing or windshield.

5. Remove windshield taking caution that the outer fairing is loose.

Continued on next page

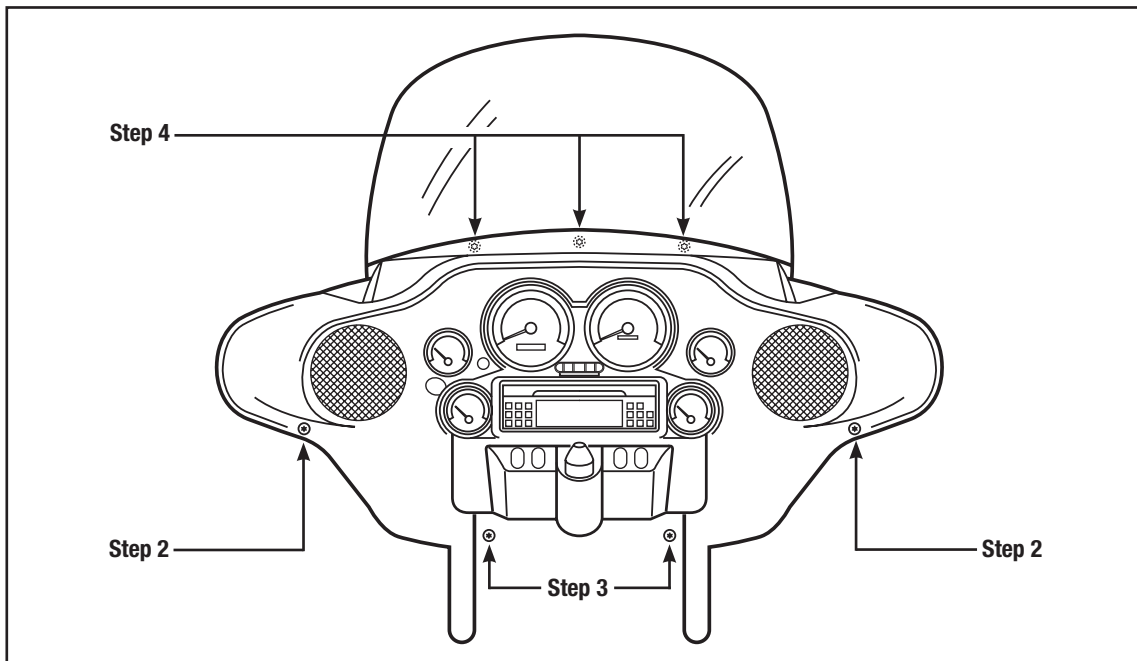

(Figure A)

Fairing Disassembly

FLH/Batwing models: (cont.)

6. Lift away and unplug headlight to remove outer fairing. (Figure B)
7. Extract (2) 3/16" Allen bolts from each side of the radio housing. (Figure C)
8. Remove the factory radio.

Continue to kit assembly

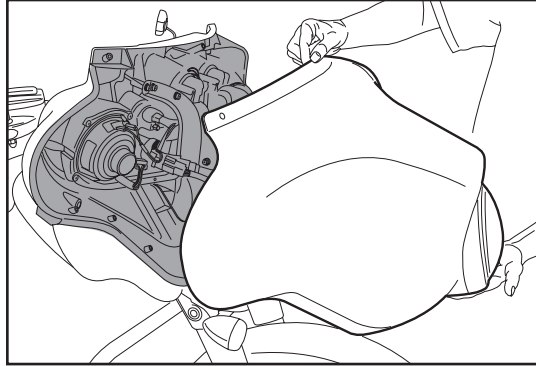

(Figure B)

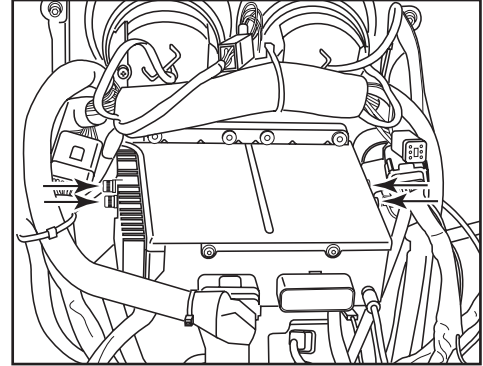

(Figure C)

Fairing Disassembly

Roadglide/Sharknose models

1. Loosen (6) T-25 Torx bolts from bottom, middle and top of left and right sides of the inner fairing. (Figure A)

Continued on next page

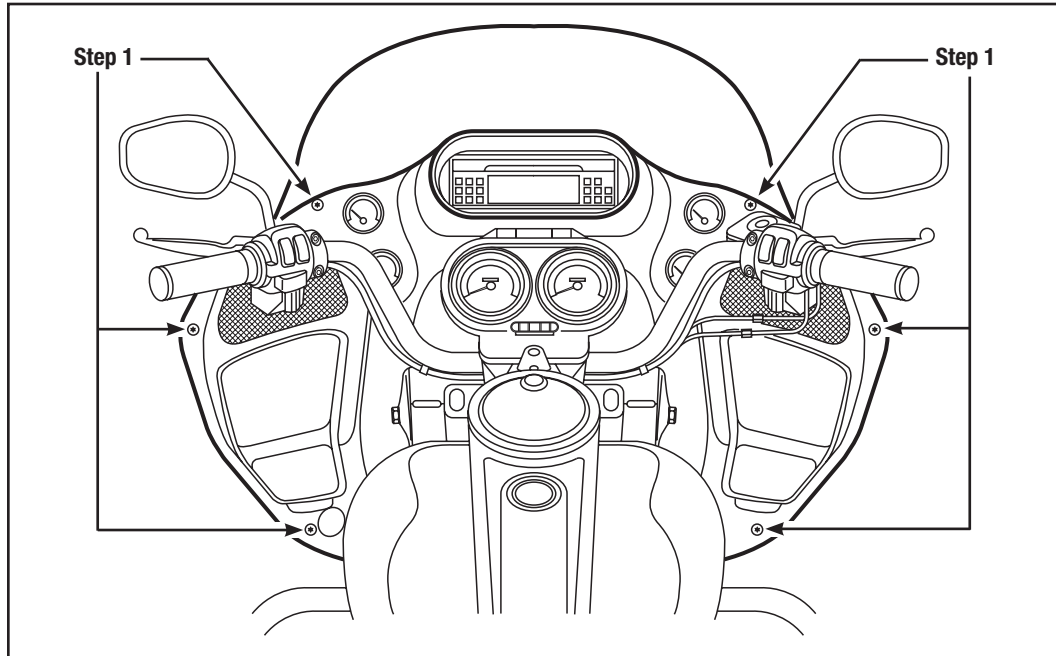

(Figure A)

Fairing Disassembly

Roadglide/Sharknose models (cont.)

2. Use a 1/2" socket or box wrench to remove the (2) acorn nuts that hold each turn signal at the lower fairing. Let the signals hang loose. (Figure B)
3. Lift away the fairing, unplug the headlights and remove.
4. Remove (2) 3/16" Allen bolts from each side of the radio housing. (Figure C)

Continue to kit assembly

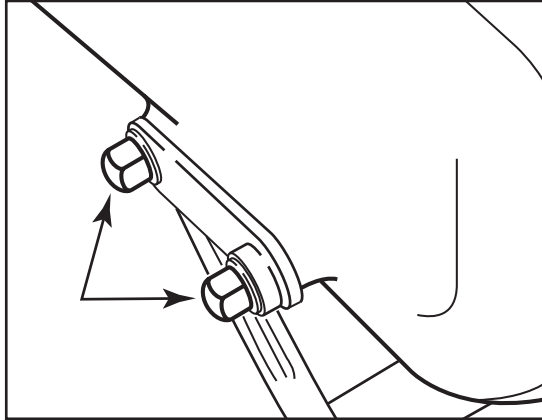

(Figure B)

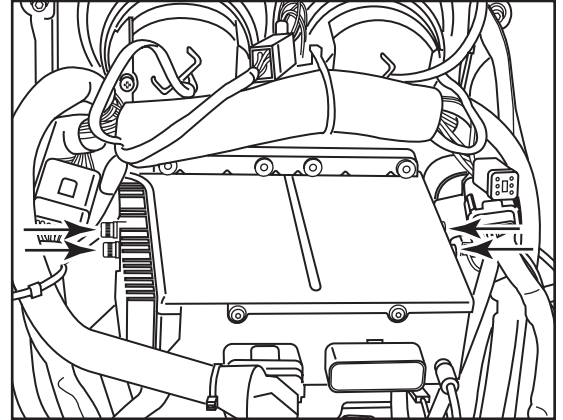

(Figure C)

ISO DIN radio provision

1. Slide the radio into radio housing and secure with screws supplied with the radio. (Figure A)
2. Slide the rubber gasket over the front edge of the radio housing. (Figure A)
3. Insert the radio and kit assembly into the factory radio opening from the back side of the inner fairing. (Figure B)
4. Secure with the factory hardware, or the included button-head screws. (Figure B)
5. Locate the factory wiring harness and antenna plug in the dash. Metra recommends using the proper mating adapters. Use the included wiring harness. The AXXESS ASWC-1 interface is sold separately for retention of factory handlebar controls.
6. Reassemble bike in reverse order of disassembly.

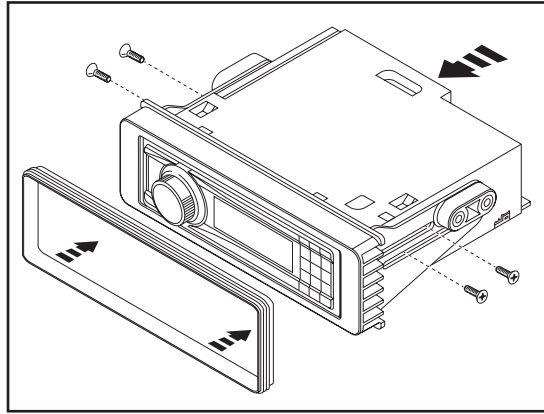

(Figure A)

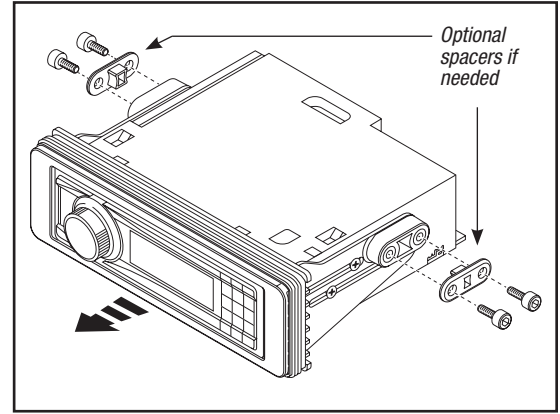

(Figure B)



Wiring Instructions 99-9600

Connections to be made

From the 23-pin harness

(a) to the aftermarket radio:

- Connect the **Black** wire to the ground wire.
- Connect the **Yellow** wire to the battery wire.
- Connect the **Red** wire to the accessory wire.
- Connect the **White** wire to the left front positive speaker output.
- Connect the **White/Black** wire to the left front negative speaker output.
- Connect the **Gray** wire to the right front positive speaker output.
- Connect the **Gray/Black** wire to the right front negative speaker output.

(b) to the vehicle:

- If the ASWC-1 (sold separately) is to be used, connect the **Pink/White** wire to the **Pink/White** wire from the vehicle. This wire is located near the left side speaker in a harness, and goes to the left side handlebar

controls (the clutch side). The **Pink/White** wire from the vehicle needs to be cut, and the **Pink/White** wire from the 23-pin harness connected towards the left side handlebar controls (the clutch side). (Figure A)

From the 12-pin harness to the aftermarket radio:

- The 12-pin harness is to be used in conjunction with the optional ASWC-1 (not included) to retain steering wheel controls. If the ASWC-1 is not being used, disregard this harness. If it will be used, please refer to the ASWC-1 instructions for radio connections and programming.

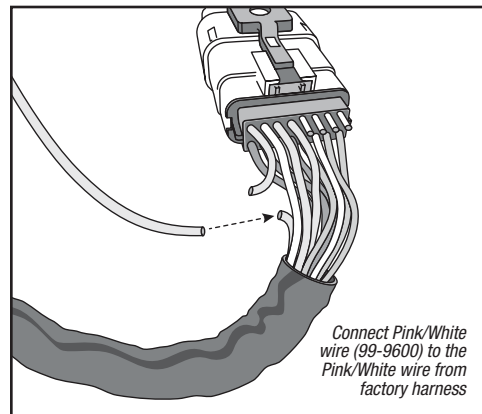

Figure A



INSTALLATION INSTRUCTIONS FOR PART 99-9600



REV. 7/1/2014 INST99-9600



KNOWLEDGE IS POWER

Enhance your installation and fabrication skills by enrolling in the most recognized and respected mobile electronics school in our industry. Log onto www.installerinstitute.com or call 800-354-6782 for more information and take steps toward a better tomorrow.



Metra recommends MECP certified technicians